

INSTALLATION INSTRUCTIONS

120S, 120SB, 120SC, 120SE, MS25-S

(ENG) **Installation Instructions**
Replacing rubber seal drive

(SPA) **Instrucciones de montaje**
Cambino de retén de goma, colas

(GER) **Einbauanleitung**
Auswechseln der Gummidichtung Antrieb

(ITA) **Istruzioni di montaggio**
Sostituzione della guarnizione di gomma, gambaie

(FRE) **Instructions de montage**
Échange de joint en caoutchouc transmis-
sions

(SWE) **Monteringsanvisning**
Byte av gummitätning drev

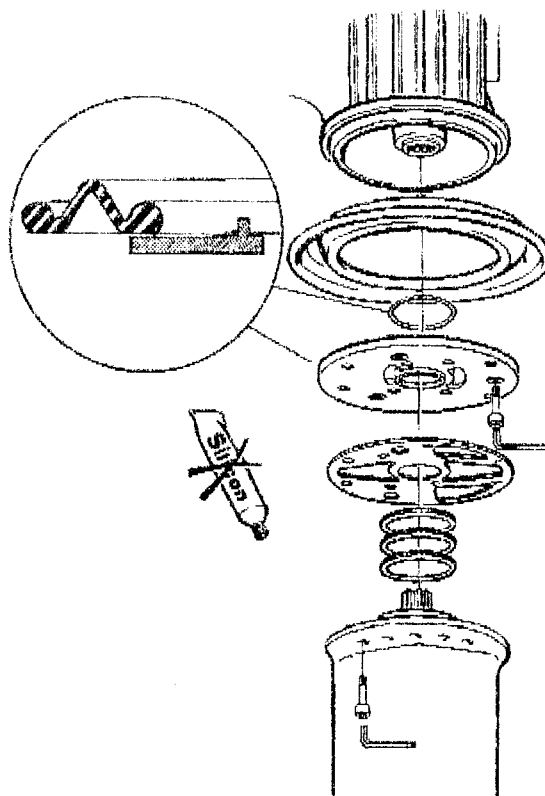

**VOLVO
PENTA**

INSTALLATION INSTRUCTIONS

120S

ENG

Installation Instructions

Extension, sail-boat drive 120S.
Kit number 3858780

SPA

Instrucciones de montaje

Prolongación de la cola para veleros 120S
Kit número 3858780

GER

Einbauanleitung

Verlängerung Segelbootantrieb 120S.
Satznummer 3858780

ITA

Istruzioni di montaggio

Prolunga trasmissione 120S per barche a
vela.
Kit numero 3858780

FRE

Instructions de montage

Rallonge, embase pour voilier 120S
Numéro de kit 3858780

SWE

Monteringsanvisning

Förlängning segelbåtsdrev 120S.
Satsnummer 3858780

**VOLVO
PENTA**

⚠ IMPORTANT!

This batch with its accompanying instructions is produced for Volvo Penta's service workshops, boat-builders, machine manufacturers and other authorized workshops which have personnel with qualified professional training.

The installation instructions are only produced for professional use and are not intended for non-professional use. Volvo Penta will not assume any liability whatsoever for damage incurred, either damage to materials or personal injury, which may result if the installation instructions are not followed or if the work is carried out by non-professional personnel.

⚠ WICHTIG!

Dieser Satz mit vorliegender Einbauanleitung ist für Volvo Penta Kundendienst-werkstätten, Werften, Maschinenbauer und für andere ermächtigte Werkstätten mit beruflich geschultem Personal vorgesehen.

Die Einbauanleitung ist nur für den berufsmäßigen Gebrauch vorgesehen und nicht für unprofessionelle Anwendung gedacht. Volvo Penta übernimmt nicht die geringste Haftung für irgendwelchen Schäden an Personen oder Sachen, die als Folge einer Nichtbefolgung der Einbauanleitung oder wegen Ausführung der darin beschriebenen Arbeiten durch nicht beruflich geschulte Personen entstehen.

⚠ IMPORTANT!

Ce kit, avec instructions de montage, est destiné aux ateliers de service Volvo Penta, aux constructeurs de bateaux et autres ateliers de construction agréés avec un personnel qualifié.

Les instructions de montage sont exclusivement conçues pour une utilisation professionnelle. Volvo Penta se dégage de toute responsabilité pour d'éventuels endommagements, corporels ou matériels, résultant du non respect des instructions ou d'un travail effectué par un personnel non compétent.

⚠ IMPORTANTE!

El presente juego con las instrucciones de montaje se destina a los talleres de servicio Volvo Penta, constructores de embarcaciones y máquinas y a otros talleres autorizados que cuentan con personal capacitado.

Las instrucciones de montaje están destinadas únicamente para uso profesional, por lo que Volvo Penta no aceptará responsabilidad alguna por cualquier daño, tanto personal como material, resultado de no haber seguido las instrucciones de montaje o de haber sido efectuado el trabajo por personal que no está debidamente capacitado.

⚠ IMPORTANTE!

Questo kit e le relative istruzioni di montaggio sono stati realizzati per le officine di servizio Volvo Penta, i cantieri, i fabbricanti di macchine e tutte le altre officine autorizzate il cui personale ha ricevuto un addestramento qualificato e specializzato.

Le istruzioni di montaggio sono state redatte esclusivamente per uso professionale e non sono adatte all'uso non professionale. La Volvo Penta non si assume alcuna responsabilità per eventuali danni alle cose o alle persone, derivanti da trascuratezza nel seguire le istruzioni di montaggio oppure dall'esecuzione dei lavori da parte di personale non qualificato.

⚠ VIKTIGT!

Denna sats med föreliggande monteringsanvisning är framtagen för Volvo Pentas serviceverkstäder, båtbyggare, maskintillverkare och övriga auktoriserade verkstäder som har personal med kvalificerad fackutbildning.

Monteringsanvisningen är enbart framtagen för yrkesbruk och är inte avsedd för icke yrkesmässig användning. Volvo Penta påtager sig inget som helst ansvar för eventuella skador, såväl materiella som personskador, som kan bli följden om monteringsanvisningen ej följs, eller om arbetet utförs av icke yrkeskunzig

⚠ VIGTIGT!

Detta sæt med tilhørende monteringsvejledning er blevet udviklet for Volvo Pentas serviceværksteder, bådebyggere, maskinproducenter og andre autoriserede værksteder, som har medarbejdere med kvalificeret, faglig uddannelse.

Monteringsvejledningen er udelukkende beregnet til professionel anvendelse og ikke til hobby- eller fritidsbrug. Volvo Penta påtager sig intet som helst ansvar for eventuelle skader på såvel materiel som personer, som kan være en følge af at monteringsvejledningens anvisninger ikke blev overholdt, eller hvis arbejdet blev udført af ikke-professionelt personale.

⚠ TÄRKEÄÄ!

Tämä sarja ja asennusohje on tarkoitettu Volvo Pentan huoltokorjaamoille, veneenrakentajille, konevalmistajille ja muille valtuutetuille korjaamoille, joiden henkilökunta on saanut pätevän ammattikoulutuksen

Asennusohje on tarkoitettu ainoastaan ammattikäyttöön. Volvo Penta ei vastaa mahdollisista materiaali- tai henkilövahingoista, joita asennusohjeen laiminlyöminen tai ammattitaidottoman henkilökunnan suorittama asennustyö voi aiheuttaa.

⚠ BELANGRIJK!

Deze set met de bijgevoegde montage-aanwijzing is ontwikkeld voor de werkplaatsen van Volvo Penta, botenbouwers, machinefabrikanten en overige bevoegde werkplaatsen, die personeel hebben met een gekwalificeerde vakopleiding.

De montage-aanwijzing is alleen ontwikkeld voor professioneel gebruik en is niet bedoeld voor niet-professioneel gebruik. Volvo Penta neemt geen enkele verantwoordelijkheid op zich voor eventuele schade, zowel materiële schade als persoonlijk letsel, die het gevolg kan zijn als de montage-aanwijzing niet wordt gevolgd, of als het werk wordt uitgevoerd door niet-vakkundig personeel.

⚠ IMPORTANTE!

Este jogo, juntamente com as respectivas instruções de montagem, foi concebido para as oficinas de serviço da Volvo Penta, construtores navais, construtores de máquinas e outras oficinas autorizadas, com pessoal devidamente formado.

As instruções de montagem foram concebidas unicamente para utilização profissional e não se destinam a utilização não profissional. A Volvo Penta não se responsabiliza por quaisquer danos eventuais, tanto materiais como pessoais, que possam resultar no caso de as instruções de montagem não serem seguidas, ou se os trabalhos forem executados por pessoal não profissional.

⚠ ΠΡΟΣΟΧΗ!

Το περιεχόμενο αυτού του πακέτου μαζί με τις οδηγίες συναρμολόγησης που το ακολουθούν είναι ειδικά επιλεγμένο για συνεργεία σέρβις της Volvo Penta, ναυπηγεία, κατασκευαστές μηχανών και για λοιπά εξουσιοδοτημένα συνεργεία που διαθέτουν εξειδικευμένο προσωπικό.

Οι οδηγίες συναρμολόγησης προορίζονται μόνο για επαγγελματική χρήση και δεν αποσκοπούν για χρήση από μη επαγγελματίες. Η Volvo Penta δεν αναλαμβάνει απολύτως καμία ευθύνη για πιθανές ζημιές, τόσο υλικές όσο και προσωπικές, που μπορούν να προκληθούν επειδή δεν ακολουθούνται οι οδηγίες συναρμολόγησης ή επειδή η εργασία εκτελείται από μη εξειδικευμένο προσωπικό.

ENG

REPLACEMENT OF RUBBER SEAL, DRIVE 120S, 120SB, 120SC, 120SD, 120SE, MS25-S.

This assembly kit contains:

Designation	Qty
Locking wire	1
O-ring 79, 5x3	1
Rubber seal	1
Gasket	1
Installation instruction	1

The rubber seal between the S-drive and the engine bed must be replaced every 7 years. Each time the boat is launched, the rubber seal must always be checked for cracking, age and wear. The instruction, which is illustrated, tracks the entire procedure, stage by stage. Since the rubber seal affects the bouyancy of the boat, it is important that the work is done with the greatest care. Since the rubber seal affects the bouyancy of the boat, it is important that the work is done with the greatest care.

Some comments on the illustrations are given below, as further tips in doing the work.

1. When the propeller is removed, it must be cleaned thoroughly. If the corrosion protection anodes are 50% or more corroded, they must be changed.
2. The amount which has to be removed from the engine and the S-drive depends on the amount of space available in the engine bay. Corroded screws must be replaced by new ones. Pack the engine up, so that rests securely and does not tip over when it is pulled forwards. If you are able to hang the engine from a block & tackle, this is a better arrangement.
3. Replace the rubber seal (4) and O-ring (2) which you removed, figure 11A, by new ones.

Note! The O-ring is not included in the 120S drive, figure 11B.

Note! No sealant may be used in the groove during assembly, figure 10.

IMPORTANT! Put the shims in a safe place. Measure the thickness of the shim package. Use the same thickness of shims in assembly. Wipe the groove clean, figure 10. No residues must be left behind.

INSTALLATION OF RUBBER SEAL ON DRIVE 120SB, 120SC, 120SD, 120SE and MS25-S FIGURE 11A.

Install the slipping clutch (1) on the vertical shaft in the upper bevel drive housing. Put the new O-ring (2) on the adapter plate (3). Fit the rubber seal (4) into the groove in the upper bevel drive housing. Put the

adapter plate in place and tighten it with the three screws (5).

Tightening torque

30 Nm (3 kpm, 22 lbsft).

Put a gasket on the mating surface of the lower bevel drive housing. This must be thoroughly cleaned. Check that the correct number of shims (thickness) (7) are installed in the lower bevel drive housing. Then pull the upper and lower bevel drive housings together with the screws (8). Tighten the fasteners in diagonal sequence, figure 12.

Tightening torque

Stage 1: 10 Nm (1 kpm, 7 lbsft).

Stage 2: 30 Nm (3 kpm, 22 lbsft).

Lock the screws with locking wire as in figure 12.

INSTALLATION OF RUBBER SEAL ON DRIVE 120S, FIGURE 11B.

Install the slipping clutch (1) on the vertical shaft in the upper bevel drive housing. Put a gasket on the mating surface of the lower bevel drive housing. This must be thoroughly cleaned. Check that the correct number of shims (thickness) (3) are placed in the lower bevel drive housing. Then fit the rubber seal (4) into the groove in the upper bevel drive housing and pull the upper and lower halves of the bevel drive housing together. Tighten the fasteners in diagonal sequence, figure 12.

Tightening torque

Stage 1: 10 Nm (1 kpm, 7 lbsft).

Stage 2: 30 Nm (3 kpm, 22 lbsft).

Lock the screws with locking wire as in figure 12.

4. Install the clamp ring, figure 13. Clean and paint with rust protection paint. Check that the underneath is flat, for effective sealing. If necessary, install a new clamp ring and new screws.

5. When the drive is installed, it is easier to connect it to the engine if the drive is lifted on blocks, up as in figure 14.

6. Engage reverse gear, figure 15. Press the engine back at the same time as you turn the flywheel right and left.

7. When you bond the collar, figure 21, use a good quality contact adhesive, intended for use on plastic and rubber.

Note! Carefully observe the adhesive manufacturer's instructions on the package.

8. Fill the engine and drive with oil. After launching, check that the rubber seal is tight and that other components which were disassembled work satisfactorily.

ENG

This assembly kit contains:

Designation	Qty	Pos
Extension	1	C
Extension shaft	1	D
Locking wire	1	
Splined sleeve	1	
Shim	6	
Screw M8x90	8	
Screw M8x110	2	
Gasket	2	

Some tips for the job are given in the comments to each illustration below.

Illustration 2.

When you install the extension, make sure that the correct number of shims (thickness) is placed beneath the bevel drive housing.

Do this as follows:

Measure distances A and B (figure 2). To find the number of shims to be added or taken away, use the following formula: $A - B = \text{correct number of shims}$

Example 1:

distance A = 3.65 mm

distance B = 3.85 mm

$$3.65 - 3.85 = -0.20 \text{ mm}$$

This means that shims of total thickness 0.20 mm must be removed

Example 2:

distance A = 3.85 mm

distance B = 3.65 mm

$$3.85 - 3.65 = 0.20 \text{ mm}$$

This means that shims of total thickness 0.20 mm must be added

NOTE!

It is important to measure the thickness of the shims. Three sizes are included in the kit.

GER

Inhalt des Einbausatzes:

Benennung	Menge	Pos.
Verlängerungsteil	1	C
Wellenverlängerung	1	D
Sicherungsdraht	1	
Keilnutenhülse	1	
Ausgleichscheibe	6	
Schraube M8x90	8	
Schraube M8x110	2	
Dichtung	2	

Als zusätzliche Hilfe bei der Arbeit nachstehend einige Anmerkungen zu den Illustrationen.

Bild 2.

Beim Einbau der Verlängerung prüfen, dass die richtige Anzahl (Dicke) von Ausgleichscheiben im unteren Antriebsgehäuse angebracht ist.

Vorgang bei der Prüfung:

Abstand A und B messen (Bild 2). Formel für die Berechnung der zusätzlichen bzw. zu entfernenden Ausgleichscheiben:
 $A - B = \text{erforderliche Anzahl der Ausgleichscheiben.}$

Beispiel 1:

Abstand A = 3,65 mm

Abstand B = 3,85 mm

$$3,65 - 3,85 = -0,20 \text{ mm}$$

Es sind also Ausgleichscheiben zu entfernen, die dem Wert 0,20 mm entsprechen.

Beispiel 2:

Abstand A = 3,85 mm

Abstand B = 3,65 mm

$$3,85 - 3,65 = 0,20 \text{ mm}$$

Es sind also zusätzlich Ausgleichscheiben einzulegen, die dem Wert 0,20 mm entsprechen.

HINWEIS!

Die Dicke der Ausgleichscheiben muss unbedingt gemessen werden. Im Satz werden drei Größen mitgeliefert.

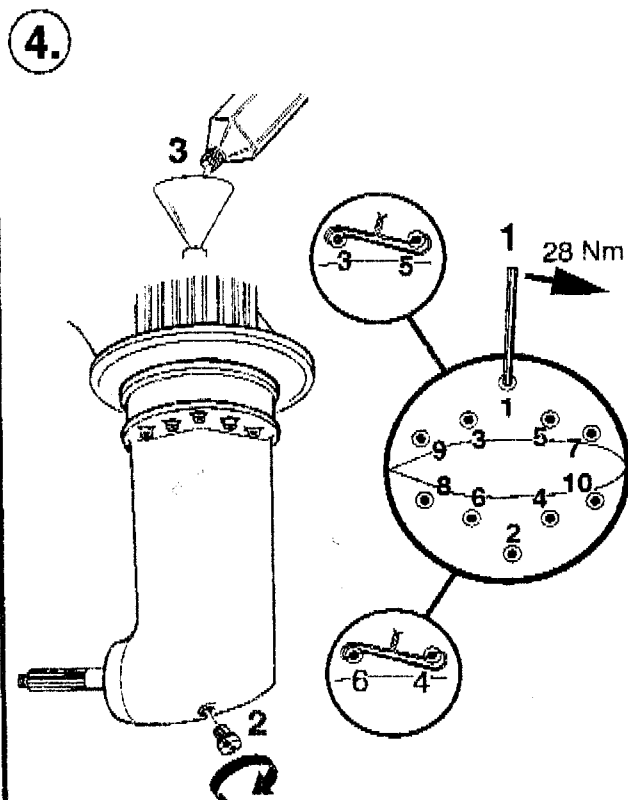
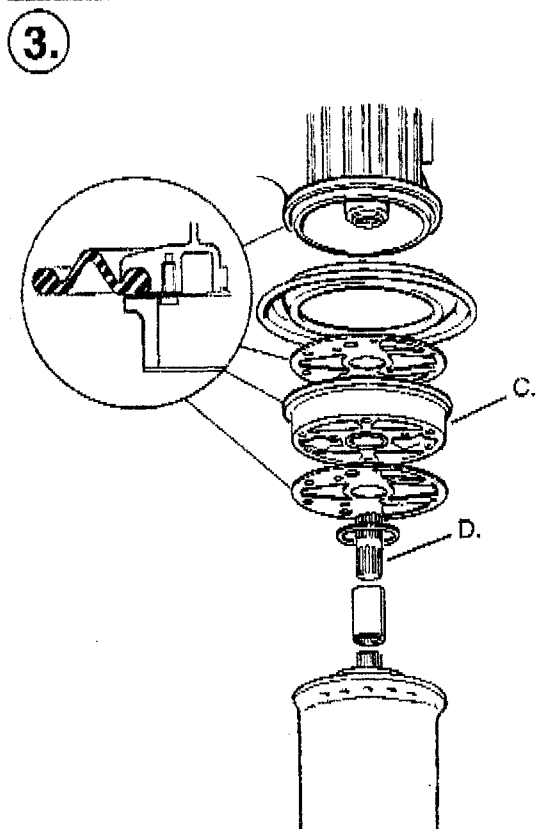
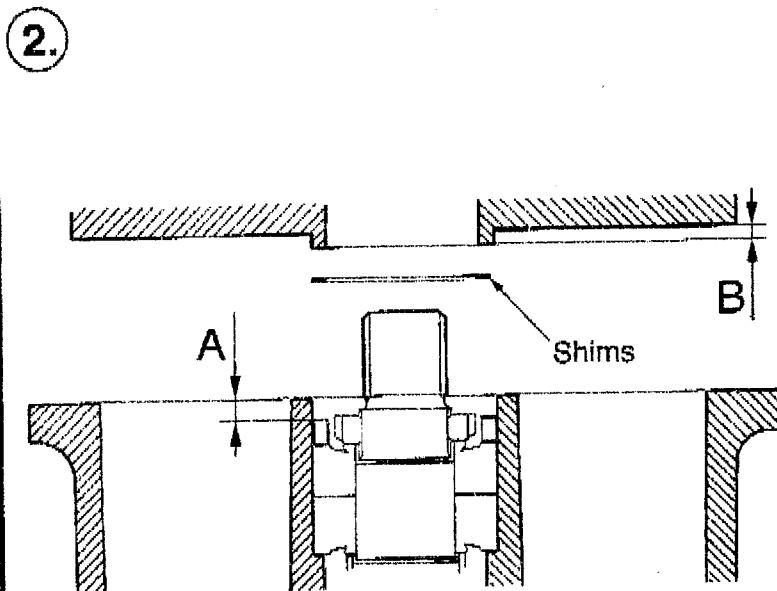
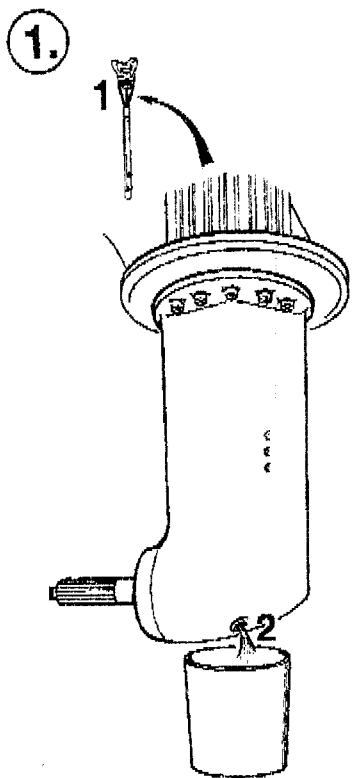

1.

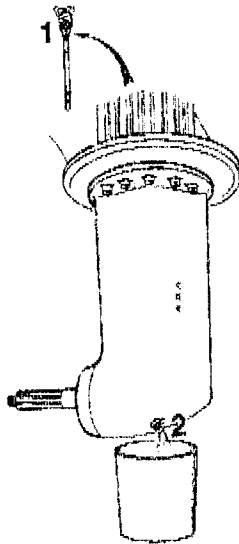

2.

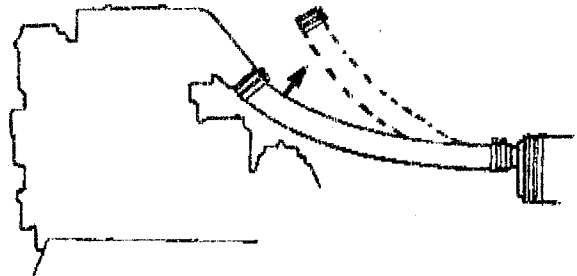

3.

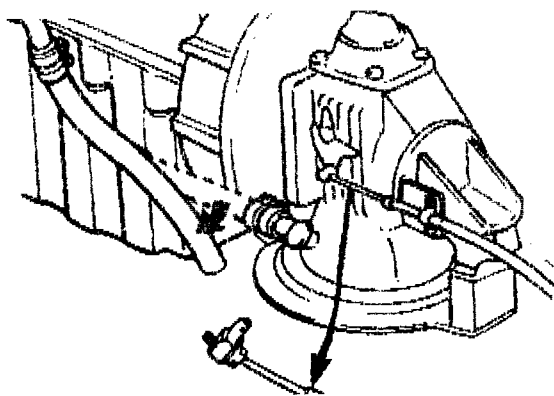

4.

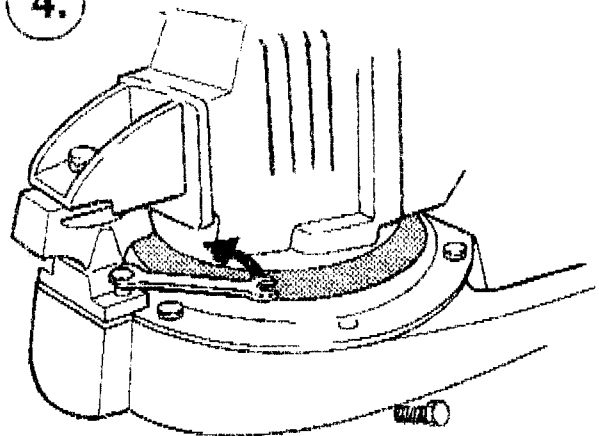

5.

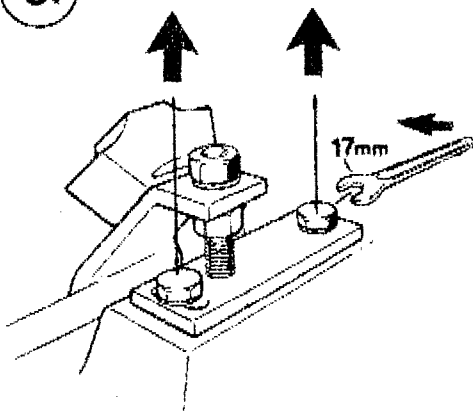

6.

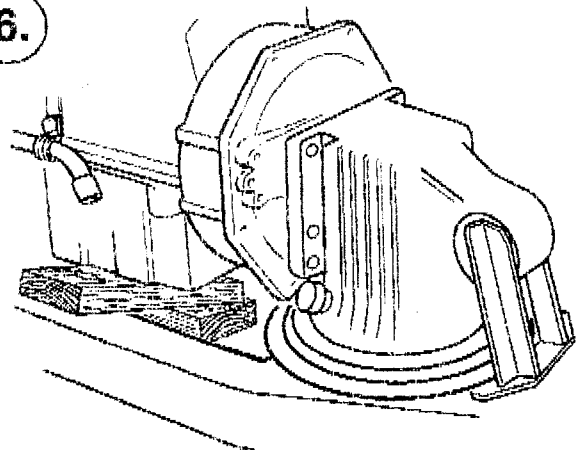

7.

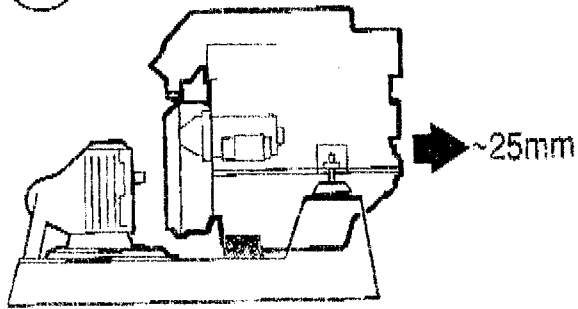

8.

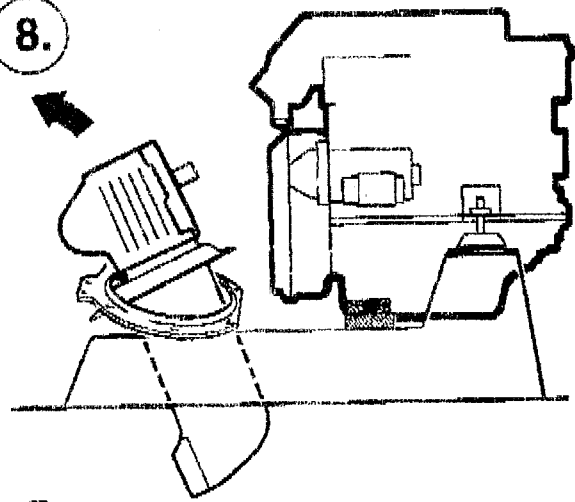

9.

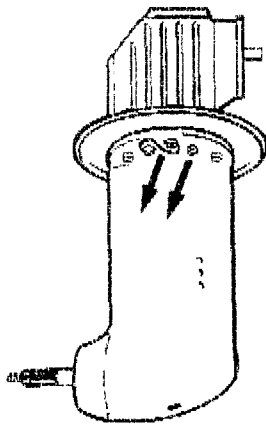

10.

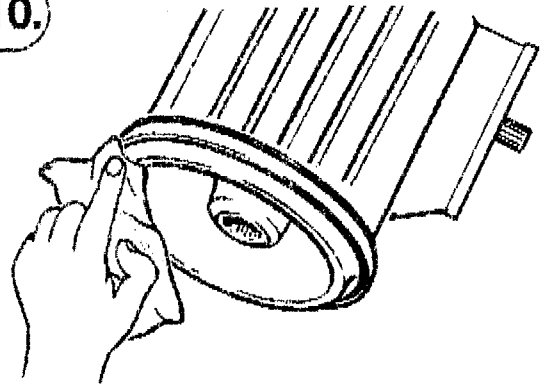

11A.

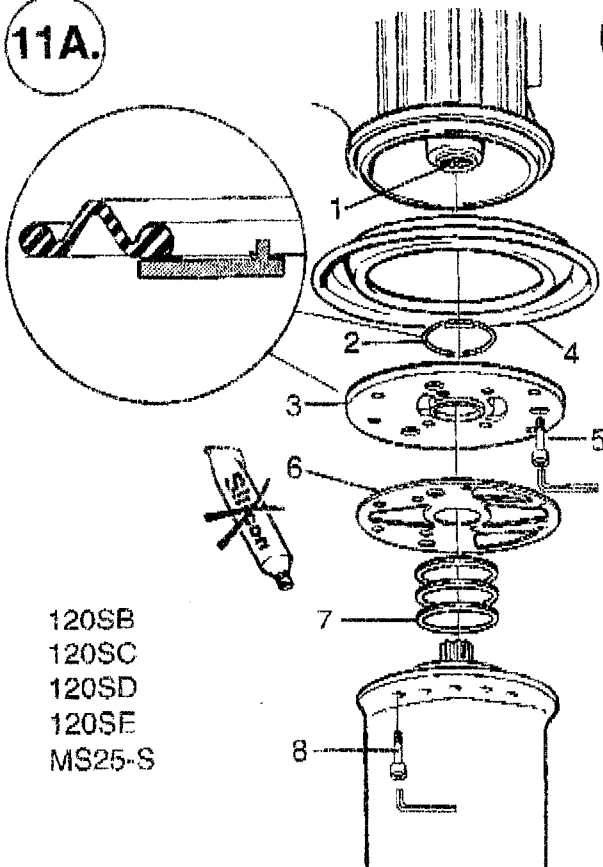

120SB
120SC
120SD
120SE
MS25-S

11B.

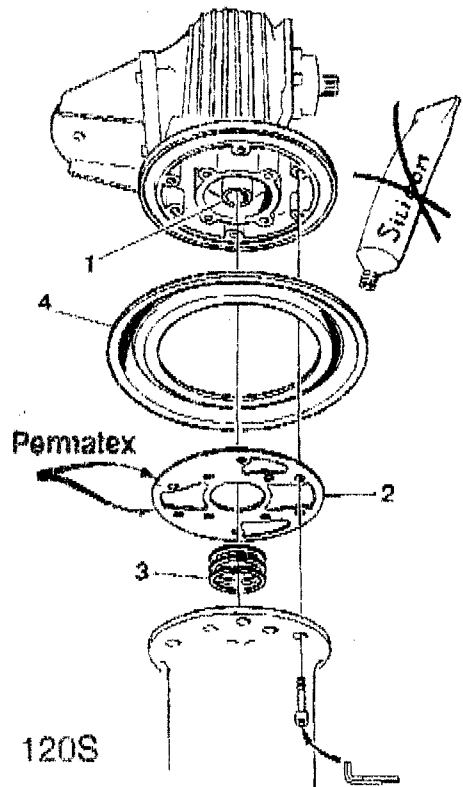

120S

12.

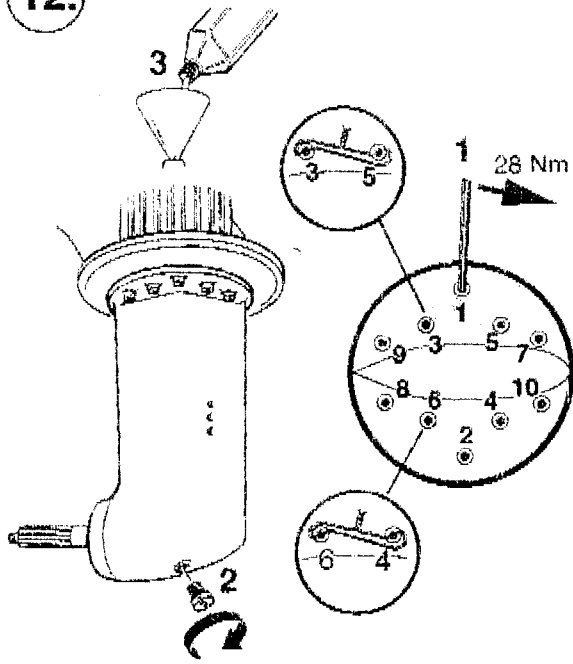

13.

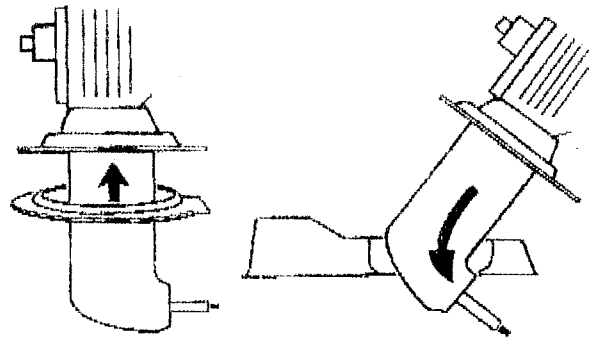

14.

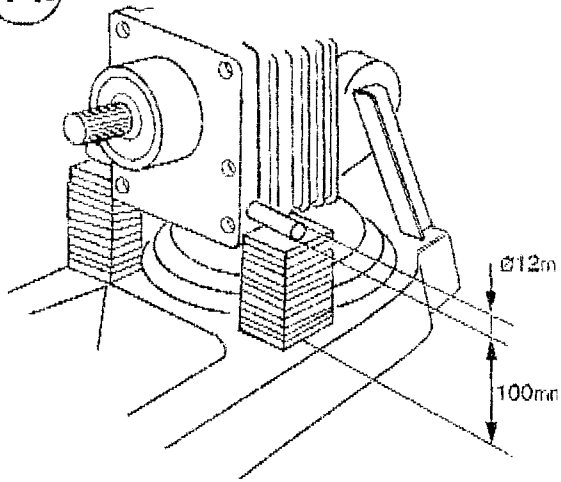

15.

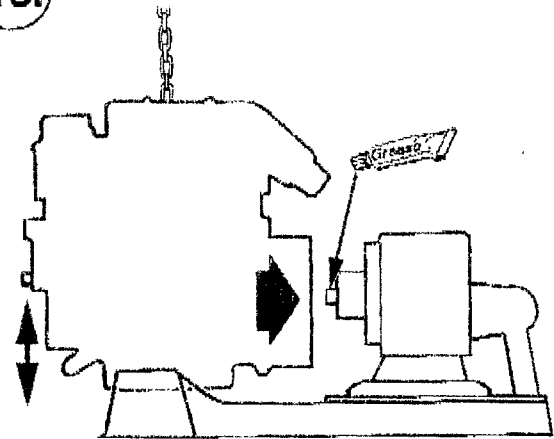

16.

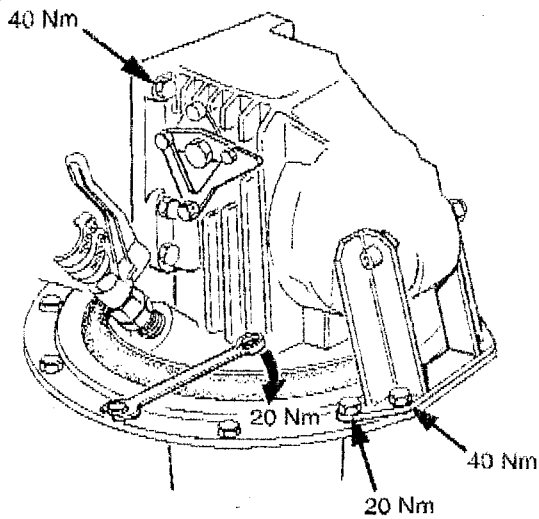

17.

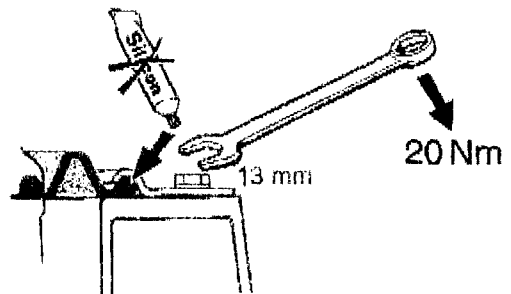

18.

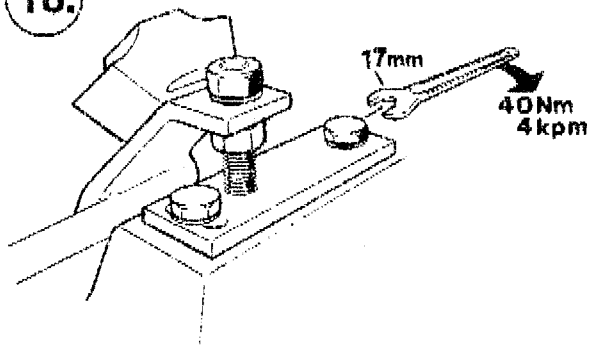

19.

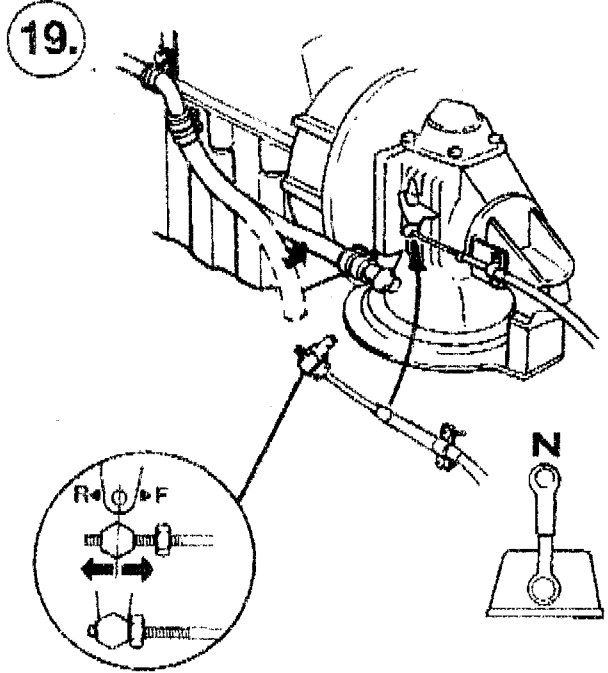

20.

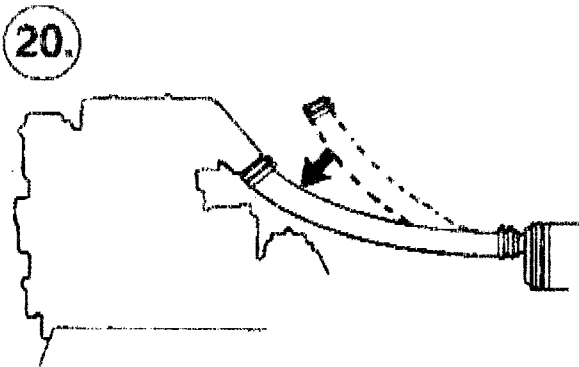

21.

