

OLYS



Bluetooth™ (option)

MPPT Bluetooth™ Dual battery solar controller

User Manual

MPPT5012A-DUO-BT | MPPT5025A-DUO-BT

Thank you very much for buying our product, Please read thoroughly before using the product

Description of Functions

- 1. Increased MPP charging current** compared with conventional controllers, due to ultramodern controller technology (microprocessor) by 10 % to 30 % (efficiency > 95 %)
- 2. Switchable characteristic lines of charging** for optimum charging of Gel/dryfit/AGM/fleece or acid/lead-acid, as well as LiFePO4 batteries .
- 3. Two Battery Charging Ports:** Automatic charging of the main battery or board battery (Board I):
Support charging and trickle charging (max. 1 A) of the vehicle's starter battery (Start II) with overcharge protection
- 4. Unattended Charging:** Standard protection against overload, overheating, reverse battery and back discharge of the battery (in case of insufficient solar power, such as at twilight, at night etc.).
- 5. Overcharge protection:** Reduction of the charging current of the battery in case of excessive solar power and full battery. Immediate recharging in case of power consumption to ensure always the best possible charging state of the battery.
- 6. Connection for temperature sensor,** Automatic adaptation of the charging voltage to the battery temperature. In case of low outside temperatures, full charging of the weaker battery is improved, and in case of summery temperatures unnecessary battery gassing will be avoided.
This is highly recommended, if the battery is exposed to strong variations in temperature, such as in the motor compartment.

Safety Regulations and Appropriate Application:

1. Charging of lead-gel, lead-AGM, lead-acid or LiFePO4 (with integrated BMS!) batteries of the indicated nominal voltage and simultaneous supply of the consumers being connected to these batteries in fixed installed systems.
2. Solar panels up to the maximum power rating (Wp) of the used solar controller.
3. The indicated cable cross sections at the charging ports and at the panel input.
4. With fuses of the indicated capacity near the battery to protect the cabling between battery and charging ports.
5. Installation in a well-ventilated room, protected from rain, humidity, dust, aggressive battery gas, as well as in an environment being free from condensation water
6. Except for the fuse, the unit is not equipped with parts, which can be replaced by the user. Always use replacement car fuses of the indicated capacity!
7. Keep children away from the solar controller and the batteries.

Connection Plan

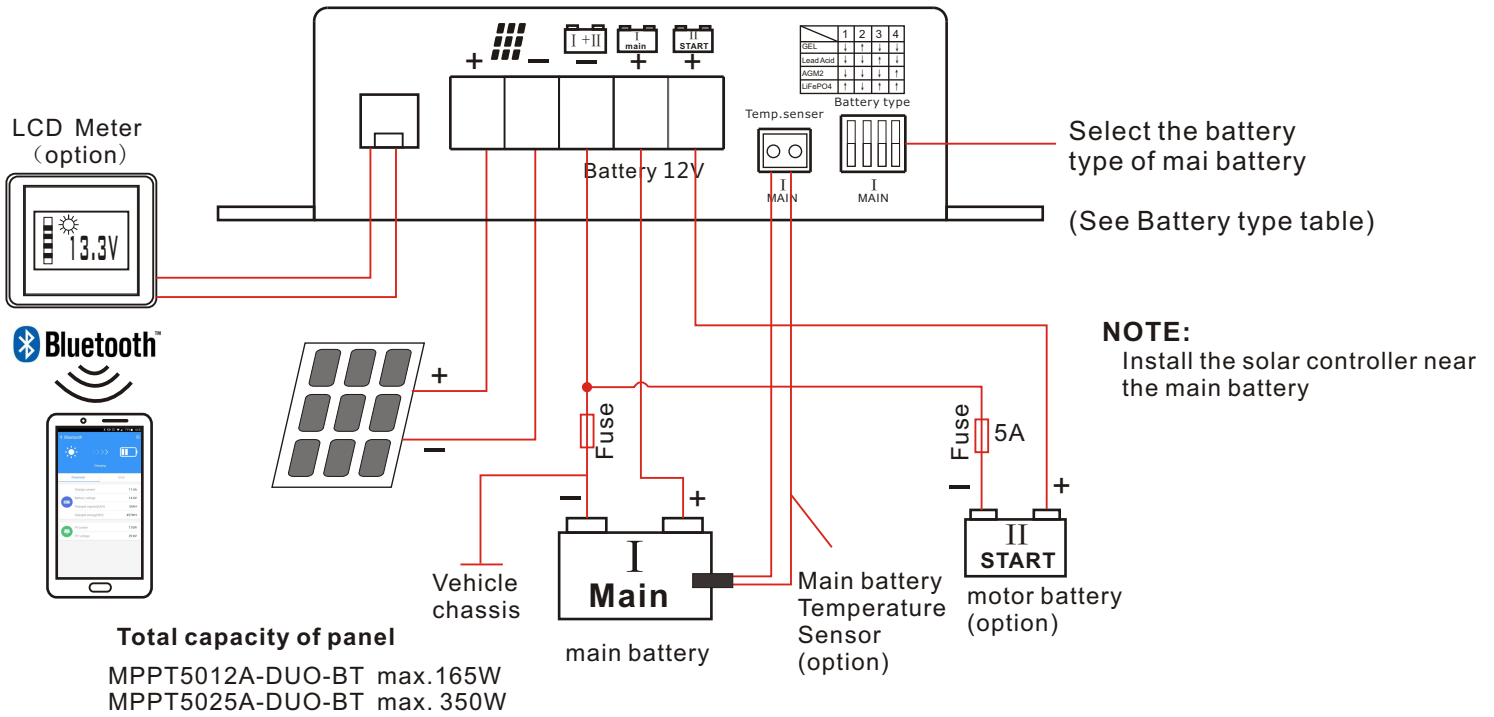

Battery selection

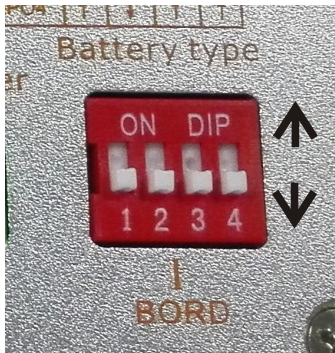

Battery type

	1	2	3	4
GEL	↓	↑	↓	↓
Lead Acid	↓	↓	↑	↓
AGM2	↓	↓	↓	↑
LiFePO4	↑	↓	↑	↑

Note:

The connection plan shows the maximum terminal assignment for operation of all existing functions of the solar controller. The minimum terminal assignment consists of the solar panel inputs ("+" and "-") and the connections of the main battery.

Always connect the fuses as close as possible to the batteries (cable protection!).

Required Cable Cross Sections, Notes	MPPT5012A-DUO	MPPT5024A-DUO
+/- Panel cables, length as required	2.5-4 mm ²	6-10 mm ²
+/- Battery I cables, length max. 2 m	2.5-4 mm ²	6-10 mm ²
Fuse close to battery I	15 A	30 A

Connection



*The polarities (+ and -) of solar panel and batteries are absolutely to be observed!

Observe the cross-sections and length measures of the cables!

*Connection of the solar controller to the battery "Board I" should be effected first. Cable Protection:

the fuses near the batteries into the + cables (protection against cable fire)!

*The solar panels should be protected from direct sunlight (by covering or shading) prior to connection.

1.) **Main Battery "MAIN I" (must be connected):**

○ Connect the **battery connections** of the controller - (Minus) and + (Plus) to the 12 V main battery, observing the correct polarity and the cross section of the cables (refer to connection plan).

○ Never operate the controller without the battery "Main I". If the battery is not connected, the unit will not deliver a defined output voltage.

○ In case of wrong polarity of battery I, the internal safety fuse will be released. The replacement fuse should have the same capacity, and it should be of the same type (car fuse)!

Parallel charging of two or several batteries of the same voltage (12 V) is admissible. The batteries are to be "paralleled"

2.) **Solar Panel (must be connected):**

Shade the panels to minimize sparking during connection and to avoid damages due to eventual wrong polarity.

Observe the cable cross-sections (refer to connection plan)!

If several small solar panels are used, they are connected in parallel (refer to connection plan). Partial shading of the panels results in average higher capacity (see connection plan).

3.) **Starter Battery „START II“ (Option, can be connected):**

Connect the second charging port to the second battery using the red connection cable (wire cross section 1.5 - 2.5 mm²). This cable may be longer. In case of non-utilization, this terminal is left free.

If used, the output for starter battery II will be working with reduced voltage and charging current rates. Thus, the valuable solar power will be supplied to board/solar battery I being more suitable.

However, the vehicles starter battery II will be kept in a condition, that starting will always be possible, even in case of longer downtimes and during winter operation.

Connection of the negative pole „START II“ is not required, if the negative pole „BOARD I“ is connected to the vehicle body. Depending on the length of the cable, it may also be connected to the common negative connection of the solar controller or to the negative pole of „BOARD I“.

4.) **Temperature Sensor (Option, can be connected):**

For automatic adaptation and correction of the charging voltage to the battery temperature (temperature compensation).

Mounting:

The thermal contact of sensor and battery "Main I" (inside temperature) should be well. Thus, it should be screwed down to the negative pole or positive pole of the battery. It is also possible to fasten it at the sidewall centre of the battery casing. Ensure that the installation place is not influenced by any source of heat (motor block, exhaust, heater etc.).

Connection:

Connect the temperature sensor to the terminal by means of a 2-pole cable (cable cross section 0.5 - 1.5 mm²). The polarity and cable length is of no importance. The solar controller recognizes the sensor automatically.

Effect:

The temperature-dependent charging voltage of battery I will be adapted automatically to the battery temperature.

The temperature sensor measures the battery temperature. In case of low temperatures (winter operation), the charging voltage will be increased in order to improve and accelerate full charging of the weak battery.

5) **LCD meter (Option, can be connected):**

The LCD display indicates the following values: Battery voltage, charging current, charging capacity, stored capacity and energy (V, A, W, Ah, Wh)

5) **Safety Mode:**

Battery Protection:

In case of too low battery temperatures (-30 °C for lead batteries or -20 °C for LiFePO₄) or too high battery temperatures (from +50 °C), the charging voltage will be reduced strongly to safety charging voltage for battery protection (depending on the type from 12.75 V to 13.00 V). Safety mode, LED "charge" is flashing, but any charging data being recorded hitherto will be kept in memory.

Battery charging is then interrupted, but the supply of eventually connected consumers will be continued by the solar controller, and the battery is allowed to cool down. As soon as the battery temperature reaches the admissible range again, automatic charging will be continued.

The solar controller recognizes automatically a missing sensor, cable break or short-circuit of the sensor lines, as well as unreasonable measuring values. In that case, it will switch automatically to the usual charging voltage rates of 20 °C / 25 °C being recommended by the battery manufacturers.

Pilot Lamps

“**Batt. Full**” (Battery fully charged, green):

- If it is lighting: Battery (batteries) has (have) been charged to 100 %, finished.
- Off: Main charging process is still effected in the charging constant current

“>80 %” (green):

- If it is lighting: Battery has been charged almost fully. Solar controller is still in the charging constant current

“**Charge**” (only MPPT5012A-DUO, green):

- If it is lighting: Charging
- Off: Solar power is insufficient.
- If it is flashing, frequency: 1time/s : controller over-heat
frequency: 2times/s: battery over-voltage. or PV over-voltage

“**MPP**”

- If it is lighting: Proper functioning of the solar controller.
- Short flashing: Display of readiness for service in case of missing solar power (at night).

“**Batt. Low**“ (yellow):

- If it is lighting: Low voltage at main battery I. voltage<10.5V

The battery should be recharged as soon as possible!

All pilot lamps (5) are flashing:

The positions of the selector switches "MAIN Battery" are incorrect. For reasons of safety, the solar controller is switched-off. Adjust the desired battery type according to table 1.

Operating Instructions:

Lifetime of the battery:

- Recharge totally discharged batteries immediately!**

Sulphation of the lead battery plates due to total discharge is to be prevented by soon charging, particularly in case of high ambient temperatures. If the grade of sulphation is not too intensive, the battery can recover part of the battery capacity after several charging/discharging cycles.

□ Partially Discharged Batteries:

In contrast to other battery types, batteries on lead basis do not have any harmful memory effect. Consequently: In case of doubt, partially discharged batteries have to be charged fully as soon as possible.

Always store only fully charged lead batteries. Recharge them periodically, particularly in case of used (older) batteries and higher temperatures.

□ Keep batteries cool and dry; choose an appropriate location for installation.

□ In case of insufficient solar power and/or high current consumption, the battery should be subject to occasional full charging by means of a mains supply charger.

□ Overvoltage Protection:

The 12 V solar controllers protect themselves against connection of excessive battery voltage rates or will be switched-off in case of defective additional charging systems, switching threshold 15.0-16.0 V.

□ Overvoltage Limitation:

Sensitive consumers are protected by means of a limitation of the charging voltage to max. 15.0 V during all modes of charging.

□ Overload / Overheating Protection Solar Controller:

The solar controller is equipped with a double electronic protection against overload and with an automatic protection against adverse installation conditions (e. g. insufficient ventilation, excessive ambient temperatures) by gradual reduction of the charging capacity.

□ **Voltage Measurement:** Measurement of the voltage is to be effected at the battery and never at the solar controller (loss at the charging cable).

Battery charging parameter

Battery type	Boost charging voltage	Float charging voltage	Default temperature
GEL	14.3V (3-10h)	13.8V	20°C
Lead Acid/AGM1	14.4V (1.5-6h)	13.45V	20°C
AGM2	14.7V (1.5-5h)	13.5V	20°C
LiFePO4	14.6V (0.5-3h)	13.6V	20°C

ATTENTION: Only connect LiFePO4 batteries with integrated BMS!

Note: The possible parallel/floating operation with consumers being connected to the battery is also automatically considered by all charging programs.

Charging Process

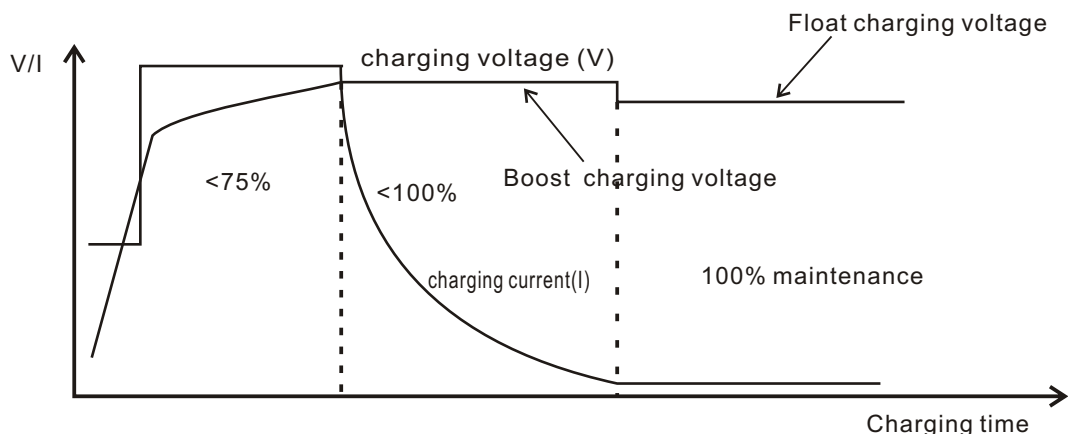

Technical Data:

	MPPT5012A-DUO-BT	MPPT5025A-DUO-BT
Capacity of Solar Module (recommended / max.):	50 - 165 Wp	50 - 350 Wp
Current Solar Module:	0 - 10 A	0 - 21.0 A
Voltage Solar Module (Voc):	max. 50 V	max. 50 V
Nominal Voltages of Batteries Main I and Start II:	12 V	12 V
Charging Current:	0 - 12 A	0 - 25.5 A
Current Consumption Stand-by (max.):	4 mA	4 mA
Main Port Battery I:		
Charging/Floating/Load Current:	0 - 12 A	0 - 25.5 A
Max. Prelim. Charg. Current (totally discharged battery):	6 A (<8 V)	12,7 A (<8 V)
Reset Voltage (30 sec):	12.7 V	12.7 V
Charging Voltage Limitation (max.):	15.0 V	15.0 V
Overload Protection (Current Limiting Device):	Yes	Yes
Integrated Protection against Short-circuit:	Yes	Yes
Integrated Protection against Overtemperature:	Yes	Yes
Integrated Cooling Fan with Temp. Control:	Yes	Yes
Unit Fuse (Type FKS):	15 A	30 A
Input for Battery I Temperature Sensor:	Yes	Yes
Charging Timer:	3-fold	4-fold
Auxiliary Port Vehicle Starter Battery II (Start II):		
Charging Current:	0 - 1.0 A	0 - 1.0 A
Overload Protection (Current Limiting Device):	Yes	Yes
Integrated Protection against Short-circuit:	Yes	Yes
Integrated Protection against Overtemperature:	Yes	Yes
Dimensions, incl. Mounting Flanges (mm):	147x74x40mm	147x74x40mm
Weight:	340g	400 g
Ambient Conditions, Humidity of Air:	max. 95 % RH, no condensation	
Available Accessories:	Temperature Sensor	
	LCD meter with Bluetooth	