

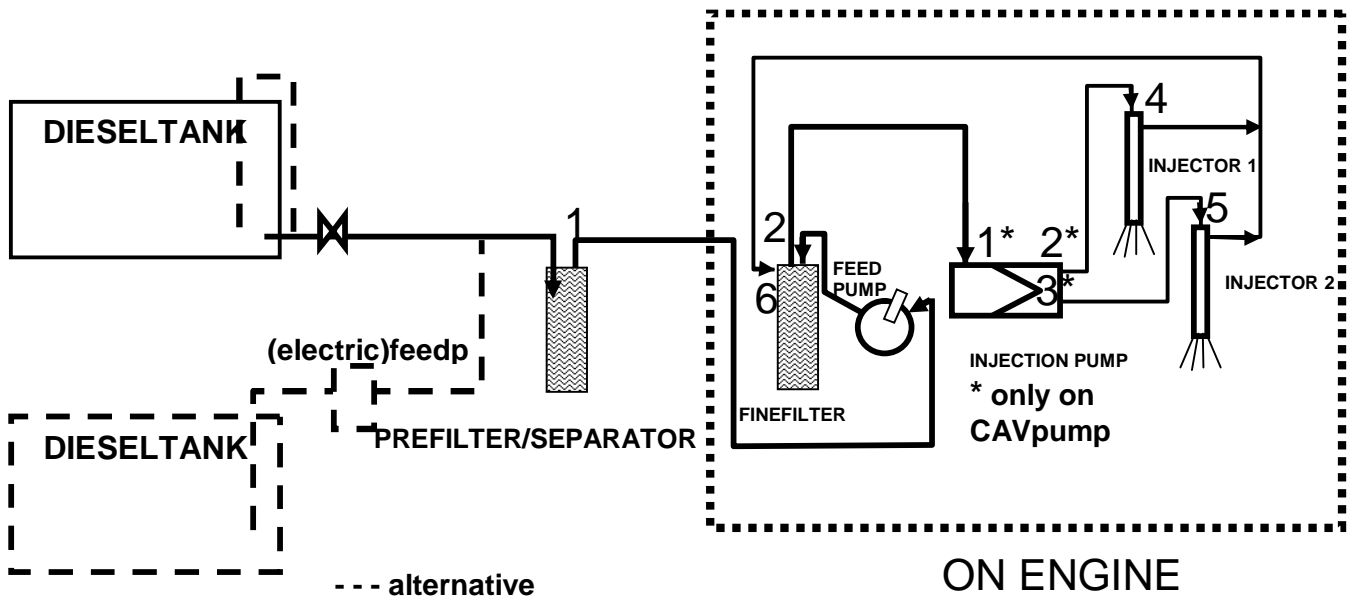



# MD7 SCHEMATIC FUEL SYSTEM AND BLEEDING POINTS

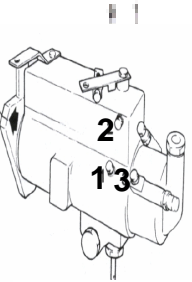

## Venting/bleeding procedures for the MD7A engine.

 <p>1</p>	<p>Open venting screw on primary filter about 4 turns. Be careful not to spill fuel. Use rags around vent opening.</p>
 <p>2</p>	<p>Pump up the fuel by using the hand primer until fuel , free from air bubbles flows out. Close vent screw. If the pump action is poor, turn the engine a bit by hand so that the cam driving the pump changes position.</p>
 <p>CAV</p> <p>3</p>	<p>If the injection pump has been removed , if air is suspected to have got into the system or after an overhaul, the injection pump must be vented. For Bosch pump: Operate hand-primer about half a minute. The Bosch injection pump is automatically vented. For CAV pump:open vent screw 1 and operate handprimer until air free fuel flows out. Tighten screw 1. Put throttle lever at full speed , open screw 2 and turn the engine with the starter motor until air free fuel flows out. Close screw 2. Open screw 3 and repeat venting with starter motor. Close screw 3.</p>
 <p>4</p>	<p>Successively loosen both injector's feed pipes nuts a bit, push in the stop control and put the throttle lever in full speed. Turn the engine using the starter motor until airfree fuel runs out the feed pipes. Do not spill fuel! Carefully tighten the delivery pipes.</p>
 <p>6</p>	<p><u>Alternately</u> turn over the engine a few seconds followed by opening the fuel return line connection on the pressure side of the feed pump a bit (9) and repeat until only fuel comes out without air bubbles. Start the engine.</p>