

Distributed by
Raymarine

Any reference to Raytheon or RTN in this manual should be interpreted as Raymarine. The names Raytheon and RTN are owned by the Raytheon Company.



Nautech Limited
Anchorage Park
Park Street
London W1A 2AA
United Kingdom
Tel: 020 7461 1234 Fax: 020 7461 1235

Autohelm 1000

AUTOHELM 1000

Your Autohelm is an up-to-the-minute digital tiller autopilot which shares the same microprocessor technology built into our biggest and most sophisticated fully installed pilots.

The Autohelm 1000 will provide precise powerful steering for sailing yachts up to 10.5m(34') LOA.

The use of your Autohelm may be extended by adding any of the following accessories:

- Windvane
- Radio Navigation Interface
- Hand Held Control Unit

Only one accessory may be used at any time

You will find installing the unit simple and enjoyable using this handbook and a minimum of hand tools

Cockpit and tiller configurations vary widely and to ensure your Autohelm installation is as neat and secure as possible a full range of tilling accessories is available from authorised Autohelm stockists. Full details are included.

In case of any difficulty please contact your main distributor or Nautech's Technical Sales Department for assistance.

Properly installed and operated in accordance with our recommendations the Autohelm will give outstanding performance even under the toughest conditions and become an indispensable member of your crew.

Good sailing!

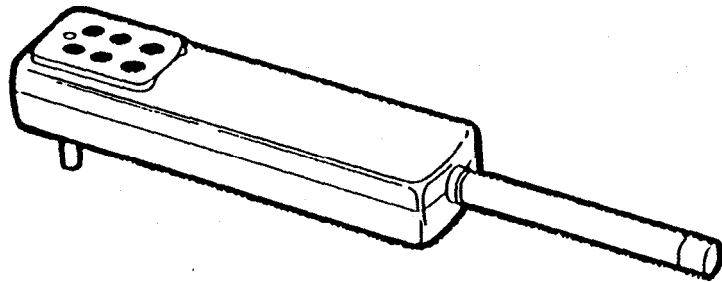

INSTALLATION

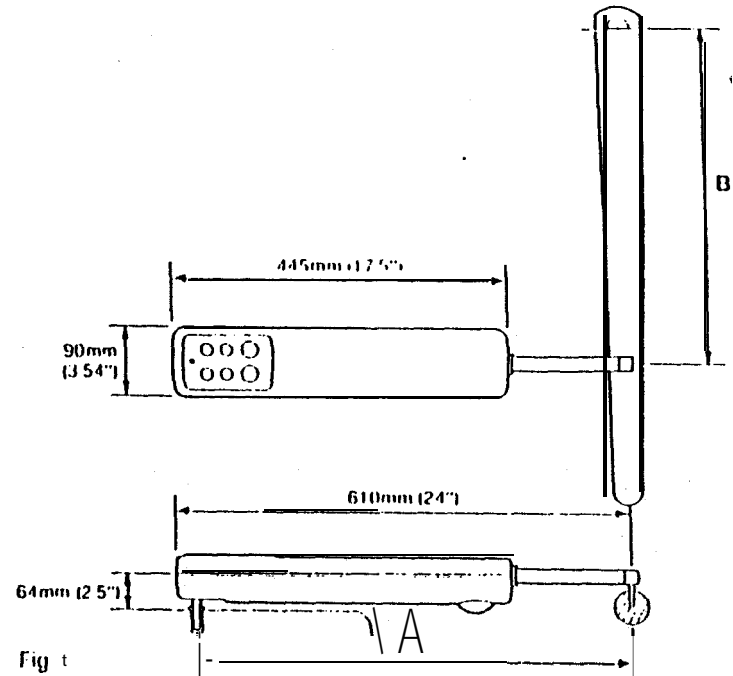

Your Autohelm is a totally self contained magnetic sensing automatic pilot. The autopilot is mounted between the tiller and a single attachment point on the yacht's structure. After connection to the yacht's 12 volt electrical system the unit becomes operational.

Since the autopilot incorporates a magnetic sensing device, it is advisable to ensure that the yacht's steering compass is situated at least 750mm (2'6") away to avoid deviation.

For correct installation two basic dimensions are critical (Fig. 1):

Dimension A = 569mm (23.2")
mounting socket to tiller pin

Dimension B = 460mm (16")
rudder stock centre line to tiller pin

Clamp the tiller on the yacht's centre line and mark off dimensions A and B (A is measured on the STARBOARD side of the cockpit) using masking tape to locate the fixing points. Ensure the measurements are at right angles as shown.

The autopilot must be mounted horizontally.

SLOPING RUDDERSTOCK

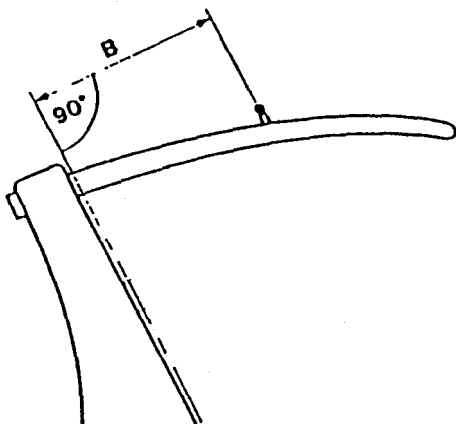

PORTHAND MOUNTING

In certain circumstances it may be more convenient to mount the unit on the porthand side. When this is the case, the changeover switch will require adjustment as follows. Remove the blanking screw and use the adjuster provided to rotate the switch anticlockwise until the endstop is reached (Fig. 2.)

Never force the changeover switch, light pressure only is required.

Finally replace and fully tighten the blanking screw to ensure watertightness.

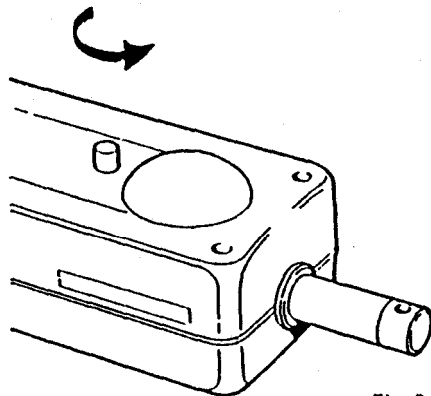

Fig. 2

BASIC INSTALLATION

After establishing the three control dimensions the autopilot can be mounted directly onto the Starboard cockpit seal (Fig. 3). Proceed as follows.

TILLER PIN (Cal No. 0001)

- Drill 6mm (1/4") hole x 25mm (1") deep at point marked.
- Using a two part epoxy such as Araldite, epoxy the tiller pin into place;
- Position the shoulder of the pin 12.5mm (1/2") above the tiller surface.

MOUNTING SOCKET

(Cal No. 0002)

- Drill 12.5mm (1/2") hole x 25mm (1") deep into the starboard cockpit seal.

- If the thickness of the mounting position is less than 25mm (1") carefully reinforce the under surface with a plywood plate epoxied into position;
- Install the mounting socket using two part epoxy;

Note The autopilot is capable of generating high pushrod loads. Ensure that:-

- The epoxy is allowed to harden thoroughly before applying any loads;
- All holes are drilled to correct size and where necessary reinforcing is provided.

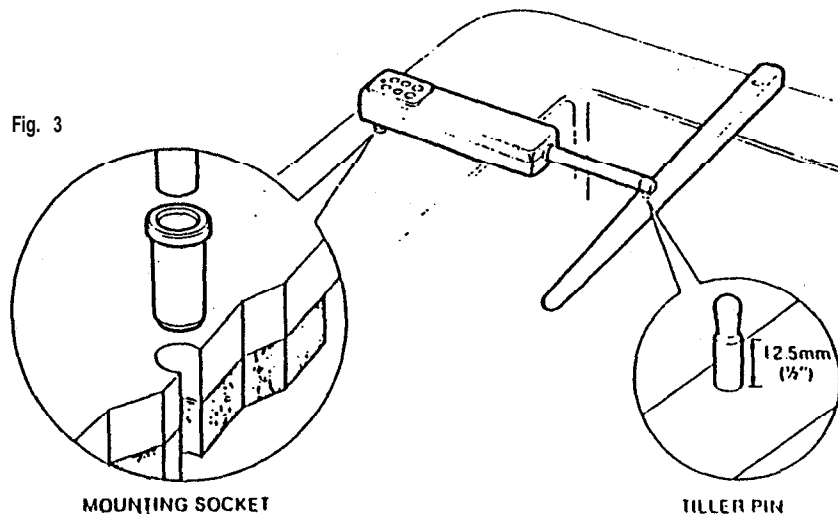

Fig. 3

MOUNTING SOCKET

TILLER PIN

INSTALLATION ACCESSORIES

If it is not possible to install your Autohelm directly onto the cockpit seat tiller as described one of the following accessories (or combination) will ensure a perfect installation.

PUSHROD EXTENSIONS (Fig. 4)

The pushrod length may be simply extended using one of the standard pushrod extensions. Dimension A is modified as follows:-

Dimension C	Pushrod Extension Length L	Cal No.
589mm (23.2")	Std Dimension	
615mm (24.2")	25mm (1")	D003
640mm (25.2")	51mm (2")	D004
665mm (26.2")	76mm (3")	D005
691mm (27.2")	102mm (4")	D006
716mm (28.2")	127mm (5")	D007
742mm (29.2")	152mm (6")	D008

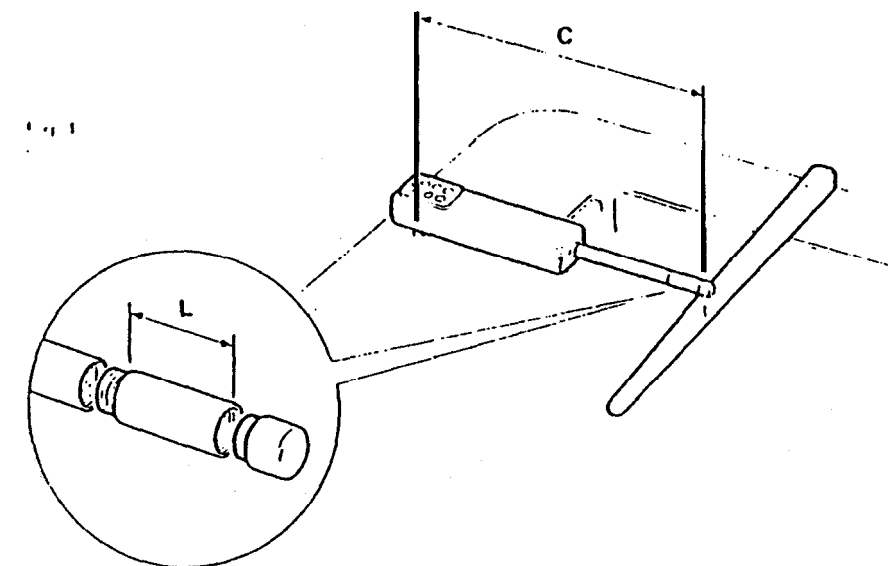

TILLER BRACKETS (Figs. 5 and 6)

Where the height of the tiller above or below the cockpit seat or mounting plane is such that standard mounting is not practical a range of tiller brackets allows the tiller pin offset to be varied.

Installation

- Position the tiller bracket on the centre line (upper/tower) of the tiller and establish control dimensions A and B.

- Mark off the position of the centres of the two fixing bolt holes.
- Drill two holes 6mm (1/4") diameter through the centre line of the tiller.
- Install the tiller bracket using 2 x 6mm (1/4") diameter bolts, nuts and washers.
- Epoxy the fixing bolts in place and fully tighten the nuts.

Dimension D (below tiller)	Dimension E (above tiller)	Cal No.
25mm (1")	51mm (2")	D009
51mm (2")	76mm (3")	D010
76mm (3")	102mm (4")	D011
102mm (4")	127mm (5")	D012
127mm (5")	152mm (6")	D013

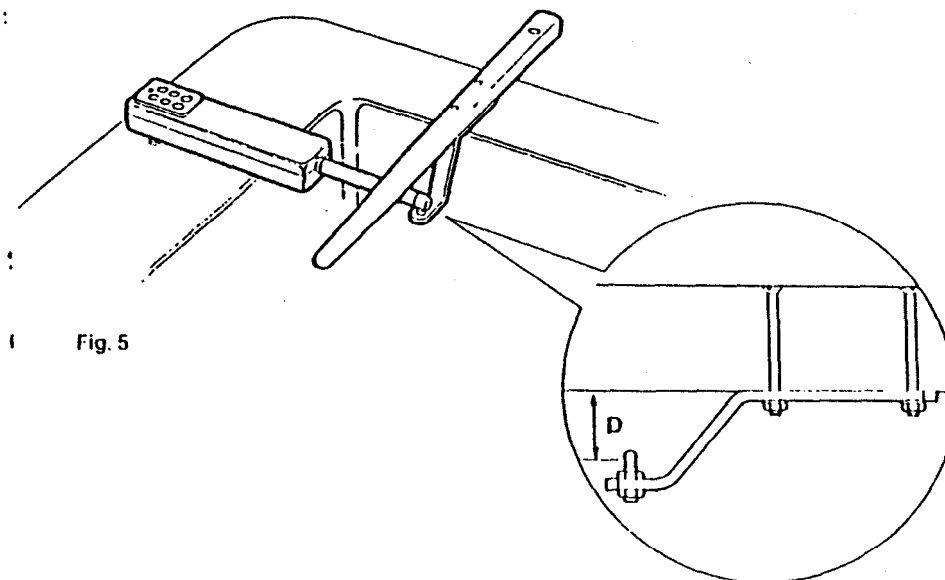

Fig. 5

SLOPING TILLER

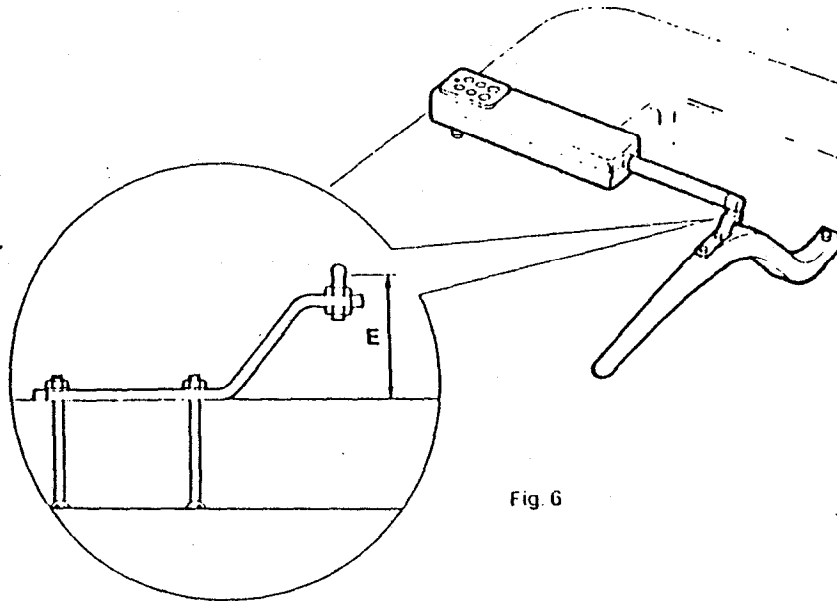
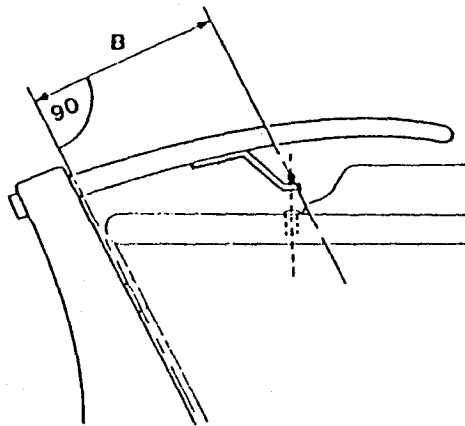

Fig. 6

CANTILEVER MOUNTING (Fig. 7)

Where it is necessary to attach the autopilot to a vertical face such as the cockpit sidewall a cantilever socket assembly is used.

The maximum extension offset is 254mm (10") and the cantilever length can be cut to the exact length necessary during mounting.

Installation

- Clamp the tiller on the yacht's centre line.
- Measure dimension F (actual)
- Refer to table to establish cutting length for cantilever rod. (Double check measurements before cutting).

Dimension F	Cut Length L
654mm (25.75")	51mm (2")
705mm (27.75")	102mm (4")
743mm (29.75")	152mm (6")
806mm (31.75")	203mm (8")
632mm (32.75")	229mm (9")

- Cut cantilever rod to length L using a hacksaw. Measure **from threaded** end.

- Remove burrs with file.
- Temporarily assemble the cantilever by screwing the rod into the mounting flange.
- Ensure the Autohelm body is **horizontal** and mark off the location of the mounting flange.
- Mark and drill 3 x 6mm (1/4") holes (ignore the two inner holes).
- Mount the flange using 3 x 6mm (1/4") diameter bolts with nuts and washers. Be sure to install the backing plate correctly. Bed the flange on a thin coat of silicon sealant.
- Screw the rod firmly into place using a tommy bar.
- Roughen the end of the rod and the inside of the cap to provide a key.
- Apply the two part epoxy adhesive provided to the rod end and cap and place the cap over the rod end.
- Ensure the hole for the Autohelm mounting pin is facing up.
- Allow the epoxy 30 minutes to fully harden before applying any load.

When the Autohelm is not in use the complete rod assembly may be unscrewed, leaving the cockpit uncluttered.

Fig. 7

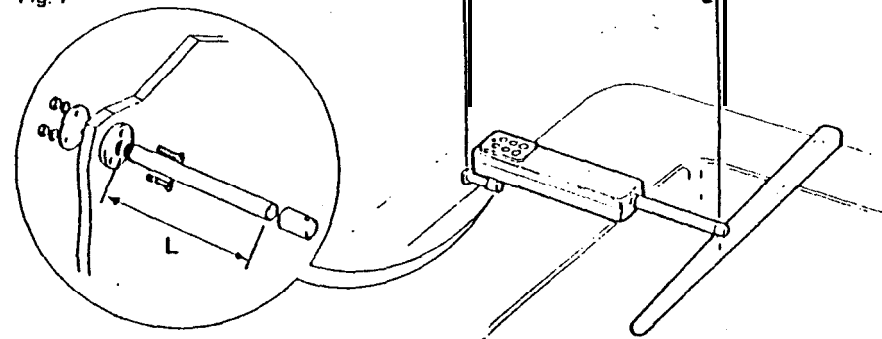

PEDESTAL SOCKET MOUNTING

It may be necessary to raise the height of the Autohelm mounting socket above the mounting surface. For this a pedestal socket assembly is used.

Selection

- Lock the tiller on the yacht's centre line
- Establish the standard control dimensions A (589mm/23.2") and B (160mm/6.3").
- Measure dimension G (Fig. 8) ensuring the Autohelm actuator is horizontal.
- Select the appropriate pedestal socket assembly from the table shown.

- Mark off the position of the mounting flange on the cockpit seat or counter.
- Ensure that control dimensions A and B are correct.
- Mark and drill 3 x 6mm (1/4") diameter holes (ignore the two inner holes).
- Mount the flange using 3 x 6mm (1/4") diameter bolts, nuts and washers, being sure the back plate is installed correctly. Bed the flange on a thin coat of silicon sealant (Fig. 9).
- Screw the mounting socket firmly into place.

When the Autohelm is not in use the mounting socket may be unscrewed to leave the cockpit uncluttered.

Dimension G	Pedestal Socket Length L	Cat No.
64mm (2.5")	Std dimension	
102mm (4.0")	38mm (1.5")	D026
114mm (4.5")	50mm (2.0")	0027
128mm (5.0")	64mm (2.5")	D028
140mm (5.5")	76mm (3.0")	0029
153mm (6.0")	89mm (3.5")	D030

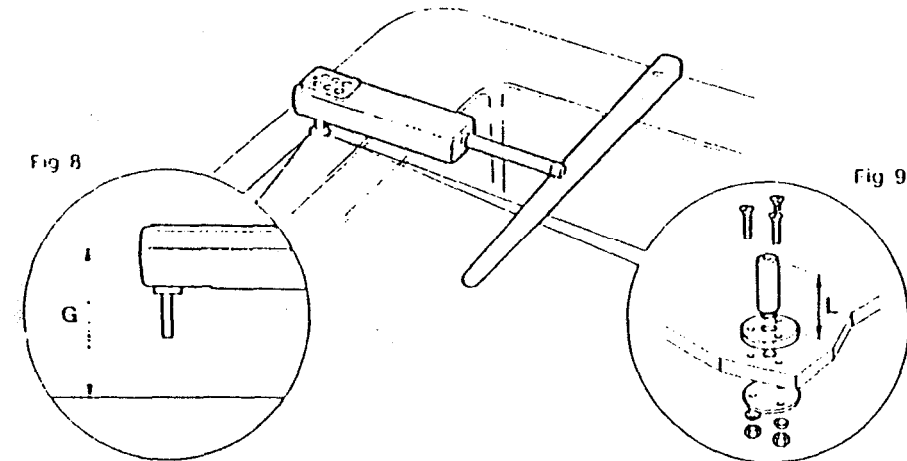

TILLER PINS

For certain non-standard installations a range of tiller pins are available.

Description	Size	Cat No.
Small threaded tiller pin	25mm (1")	D014
Extra length tiller pin	72mm (2.0")	D020
Extra length threaded tiller pin	72mm (2.0")	D021

Battery Connection

The waterproof 'Dri-Plug' supplied should be situated as close as possible to minimise lead length. The Dri-Plug socket must be connected directly to the vessel's electrical distribution panel and on no account paralleled into existing wiring for other equipment.

The Autohelm supply must be independently switched and protected by a 5 amp fuse or current trip.

Since the autopilot is microprocessor based it is very important that voltage losses in supply cables are minimised. Supply cables should therefore be as

short as possible and of no less size than shown in the following table.

The brown wire of the power-supply lead should be connected to **positive** if connections are accidentally reversed the autopilot will not operate but no damage will result.

Lead Length	Copper Area
up to 2.5m (8')	1.0mm ²
Up to 4.0m (13')	1.5mm ²
up to 6.5m (22')	2.5mm ²

WINDVANE ATTACHMENT

The windvane attachment is normally mounted centrally on the after rail where it can be sited in clear wind on both backs. The windvane mounting mast is clamped to the after rail by the two 'U' bolts provided (Fig. 10). The interconnecting cable should be brought through the slot to allow the windvane head to be plugged into the top of the mast (Fig. 11). The interconnecting cable can then be run back and plugged into the Autohelm.

After the vane head and mounting mast installation is complete the windvane should be assembled and secured by means of the circlip provided (Fig 12) Care should be taken to ensure that the small circlip is correctly located in the groove

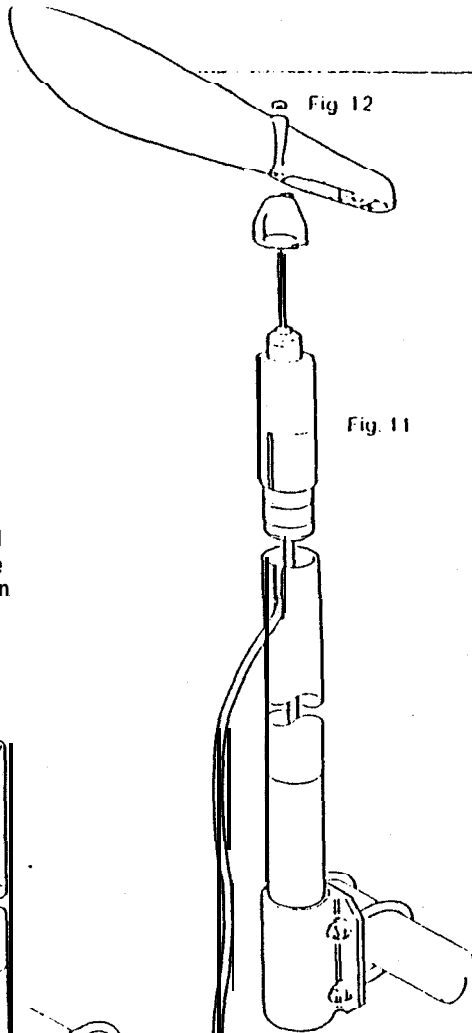
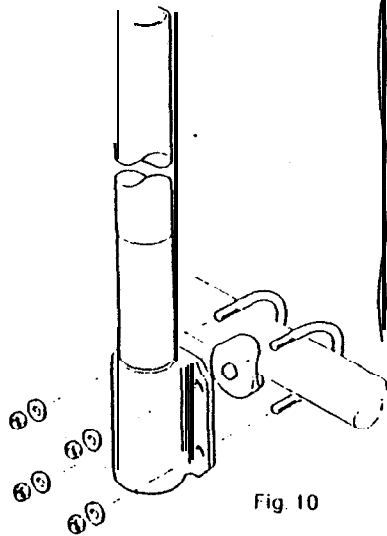

Fig 12

Fig. 11

OPERATION

BASIC PRINCIPLES

The following description of the Autohelm's principle of operation will help you to make full use of its advanced features.

The most apparent of these features is the absence of a compass dial and the addition of a six button keypad. Using the powerful combination of microprocessor and fluxgate compass, the keypad provides autolock course selection and precise pushbutton course adjustment. Once the pushrod is connected to the tiller the current heading as read from the main steering compass can be maintained simply by pushing the Auto button. Changes to the selected heading are made using the four course change buttons.

Deviation from the set course is continuously monitored by the sensitive fluxgate compass and corrective rudder is applied to return the vessel to course. The applied rudder is proportional to course error at any time and thus when the course is restored the rudder will be neutralised.

When changes in vessel trim occur due to variations in wind pressure or engine throttle setting the course can only be maintained by the application of

permanent rudder off-set (sliding helm) to restore balance. If permanent rudder off-set is not applied to restore balance the vessel will bear on to a new heading. Under these circumstances the Autohelm detects that the original course is not being restored and continues to apply additional rudder off-set in the appropriate direction until the vessel returns to the original heading. Automatic trimming capability ensures that the originally set course is held irrespective of any changes in balance that may occur during the course of a passage.

Autohelm's computer also continuously monitors the pattern of applied rudder correction and can distinguish unnecessary repetitive corrections caused by pitch and roll of the vessel from those necessary to maintain the selected heading. The computer will automatically neglect all unnecessary corrections so that autopilot activity and power consumption is continuously optimised at minimum levels.

The high degree of control automation made possible by the micro computer simplifies user control to a series of push button operations.

Micro

KEYPAD FUNCTIONS

Full control of the Autohelm is provided via a simple six button key pad.

The basic control functions are as follows:-

When the autopilot is switched on it will always start up in **Stand by** mode. In **Stand by** mode the pushrod can be extended or retracted to engage with the tiller pin using the four black buttons.

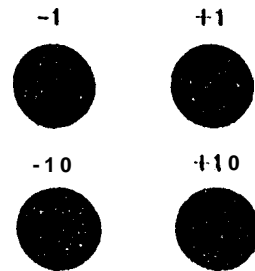
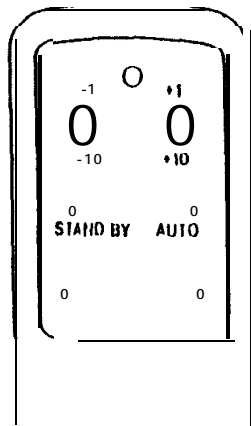

Push and hold down to extend/retract (+/-) the pushrod.

AUTO



Push once to engage the autopilot to maintain the current heading or push **twice** (within 2 seconds) to return to the previous automatic heading.

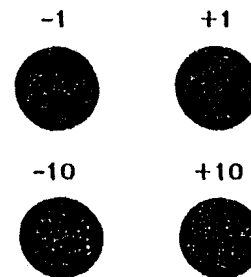

Push to alter course to port (-) or starboard (+) in increments of 1 and 10 degrees.

STAND BY



Push once to disengage the autopilot and return to Stand by mode. (The previous automatic heading will be memorised).

WINDVANE SYSTEM

Performance under wind vane has been improved by the introduction of Wind Trim.

In Wind Trim the computer uses the fluxgate compass as the primary heading reference. However, as changes occur in the apparent wind angle the computer automatically adjusts the compass heading to maintain the original

apparent wind angle.

This system eliminates the effects of turbulence or short term wind variations and provides smooth precise performance under wind vane with minimum current consumption.

When a windvane system is fitted, a new layer of control functions is automatically opened as follows:-

	<p>Push both red keys together once to engage the windvane and maintain the current apparent wind angle. Or Push both red keys together twice to return to the previous apparent wind angle.</p>
<p>-1 +1</p> <p>-10 +10</p>	<p>Push once to alter the vessel's heading, relative to the apparent wind in increments of 1 or 10 degrees. The ± keys always turn the vessel to starboard.</p>
<p>STAND BY</p> <p>AUTO</p>	<p>Push once to disengage the windvane for manual steering. (The previous apparent wind angle will be memorised). Or Push once to change over to automatic compass heading control and maintain the current heading.</p>

AUTOTACK FUNCTION

The Autohelm has an automatic tacking function which operates in both compass and windvane mode as follows:-

<p>-1</p> <p>-10</p>	<p>Push -1 and -10 keys together once to initiate a tack to port.</p>
<p>+1</p> <p>+10</p>	<p>Push +1 and +10 keys together once to initiate a tack to starboard.</p>
<p>The Auto Tack function operates by selecting a pre-set course change (100°) to bring the vessel onto the opposite tack. During the tack, the Off Course Alarm may sound. This indicates the autopilot is adjusting trim to acquire the new course. On completing the tack and having sheeted and retrimmed the sails, the vessel may be brought onto the desired apparent wind angle by line adjustments to the course using ±1° buttons. No adjustments should be made within 1 minute of completing the tack to allow the Autopilot to compensate for the helm trim on the new tack.</p>	

OPERATING MODE

INDICATION

The operating mode is indicated by a flashing LED as follows:-

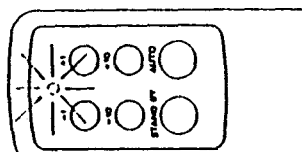

OPERATING MODE	LED FLASHING CODE
STANDBY Enables the pushrod to be positioned over the tiller pin and provides power steering.	
AUTO Autopilot steers to maintain compass heading.	
WINDVANE Autopilot steers to maintain apparent wind angle. Windvane mode is also confirmed by a single beep tone emitted every 30 seconds.	
SECONDS	

ACCESSORIES

The use of your Autohelm may be extended by adding any of the following accessories:

- Windvane
- Radio Navigation Interface
- Hand Held Control Unit

All accessories plug into the Autohelm alongside the power supply cable.

Hand Held Control Unit (Cat No. Z076)

An optional hand held control unit can be plugged into the Autohelm to provide full course change capability from anywhere on board. The unit duplicates the main control units four course change keys. The operation of the autopilot is unchanged when the hand held control unit is connected.

Radio Navigation Interface (Cat.No. Z075 - NMEA format)

This interface may be used with any radio navigation system that outputs cross track error to either the NMEA 0180, 0182 or 0183 standard. It supervises the Autohelm to maintain the preselected track set on the radio navigation system. Full operating details are supplied with each interface.

Your main distributor or Naucleis Product Support Department will be able to advise you of Radio Navigation Systems with suitable autopilot output.

- Note:**
- Always switch your Autohelm off before plugging in any accessory.
 - Only one accessory may be used at any time.

FUNCTIONAL TEST PROCEDURE

After completing the installation you should carry out the following functional test to familiarise yourself with the system before attempting sea trials.

Plug the Autohelm into the power socket and switch on the electrical supply. The unit will emit a short beep tone to indicate that it is active and the LED will flash to indicate Stand by operating mode.

Ensure the mounting pin is engaged in the socket. Using the course control keys to extend or retract the pushrod, position the end over the tiller pin. The unit will emit a short beep tone on each press of a key to confirm valid entries. Place the pushrod end on the tiller pin, and press the +10 key. The tiller should move to port. If the tiller moves to starboard, the changeover switch is incorrectly set and must be adjusted as described on page 2.

Press Auto to place the autopilot under compass control. The LED will be lit constantly to indicate that the unit is in Auto mode. If the yacht is swinging about its mooring, you will see that small variations in heading cause the unit to apply corrective action to the rudder. Press Stand by to return the unit to Stand by mode.

Initial sea trials should be carried out in calm conditions with plenty of sea room. The previously conducted functional test will have verified that the autopilot is operating correctly and that you are familiar with all of its controls.

During first sea trials, the vessel will be constantly changing heading, and it is, therefore, very important to maintain a constant look-out. The following initial trial procedure is recommended:-

- Steer on to a compass heading and hold the course steady.
- Using the four course control keys, position and then place the pushrod end over the tiller pin.

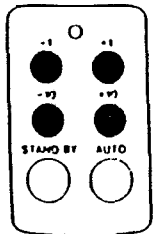

- Press Auto to lock on to the current heading. In calm sea conditions a perfectly constant heading will be maintained.

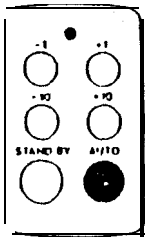

- Alter course to port or starboard in multiple increments of 1 and 10 degrees.

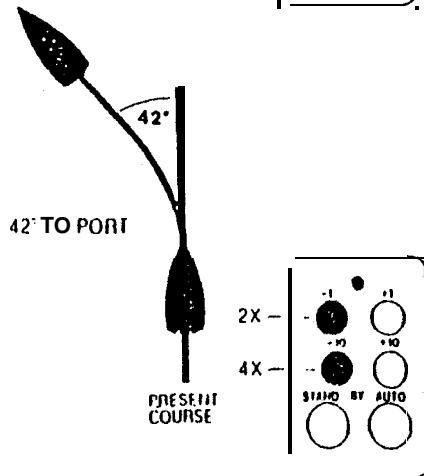
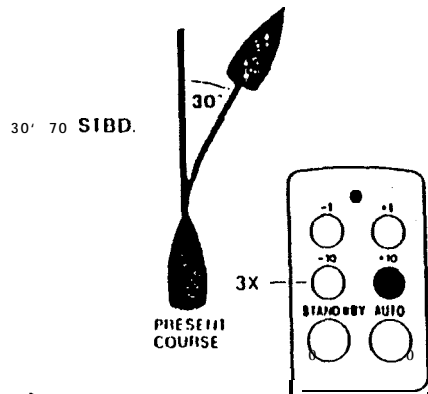

Power Steering

- Press Stand by and practice power steering using the four course control keys.
- Press Auto twice (within 2 seconds) to return to the original automatic heading.

Hand Steering

- Press Stand by and lift the autopilot from the tiller pin for return to hand steering.

Auto Tack Function

The following additional trial is recommended:

- Steer onto a constant heading approximately 10° free of close hauled.
- Press Auto to lock onto the current heading or both red keys to lock onto the apparent wind if a vane is fitted.

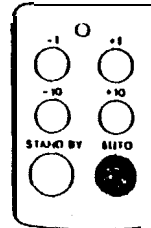

- Decrease the apparent wind angle using the \downarrow key (if on the starboard tack) until the yacht is sailing close hauled at optimum penetration.

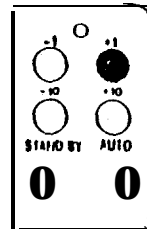

- Prepare to tack and then press the +1 and \downarrow keys together (if on the starboard tack) to initiate a tack to starboard.

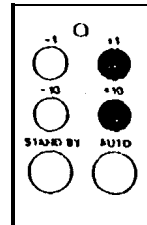

- The yacht will complete a 100° course change to bring it onto the opposite tack.

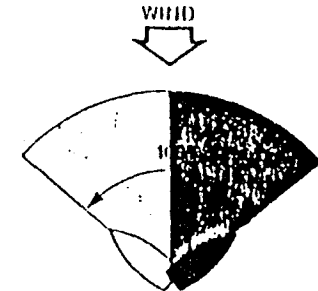

On completing the tack and having sheeted and retrimmed the sails, the vessel may be brought onto the desired apparent wind angle by line adjustments to the course using the $\pm 1^\circ$ buttons. No adjustments should be made within 1 minute of completing the tack to allow the Autopilot to compensate for the helm trim on the new tack.

OPERATING HINTS

Disengagement

The pushrod is held into engagement with the tiller pin merely by the weight of the actuator unit. This method of engagement is secure and has been adopted for safety reasons to allow the pushrod to be easily disengaged when manual override becomes necessary.

OFF-COURSE ALARM

When the autopilot is set to either Auto or Vane mode a built in off-course alarm is automatically set up. The off course alarm will sound when the vessel deviates for any reason from the original course by more than 15° degrees for over 10 seconds. It is denoted by a continuous series of beep tones.

The alarm will be silenced if the vessel returns to within 15 degrees of the original course.

In Auto, if the vessel does not return within these limits the alarm can only be silenced by selecting Stand by.

In Vane, the alarm will sound when the wind direction changes by more than 15 degrees and may be accepted by pressing both red keys together. This will silence the alarm and advance the off course alarm datum to the current compass heading.

CURRENT LIMITING AND CUTOUT

If the autopilot is driven into its end stops, the drive will be pulsed to prevent overloading the motor. If the pilot is left in this condition for 30 seconds the microprocessor will automatically cut out power to the motor and sound the alarm continuously.

To restore the autopilot for normal operation the Stand by key must be pressed to put the unit in Stand by operating mode.

AUTOMATIC SEA STATE CONTROL

During the sea trial, the operation of the automatic sea state control can be observed. When the autopilot is initially engaged in Auto mode the autopilot will respond to all pitch and roll movements. During the first minute of operation, it will be noticed that repetitive movements of the vessel are gradually neglected until finally the autopilot will respond only to true variations in course.

To ensure accurate course adjustment the sea state control is automatically reset whenever a 10 degree course change is executed.

Sea State Inhibit

Where maximum course keeping accuracy is required the automatic sea state control may be inhibited by - 1 and + 1 keys together (ONC).

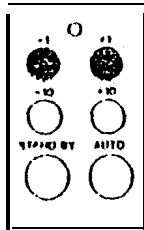

Autopilot activity and therefore power consumption will be increased but course keeping accuracy will be maximised.

The automatic sea state control is restored by pressing the -1 and +1 keys together.

Note: Engaging the autopilot (pushing Auto) or engaging the windvane (both red keys together) will always restore the automatic sea state control.

The Autohelm's computer continuously optimises automatic steering performance eliminating the need for operator supervision.

It is, however, very important to understand the effect of sudden trim changes on steering performance. When a sudden change in trim occurs the automatic trim compensation system requires approximately 60 seconds to apply the necessary rudder off-set to restore the automatic heading. In gusting conditions, therefore, the course may tend to wander slightly, particularly in the case of a sailing yacht with badly balanced sails. In the latter case, a significant improvement in course keeping can always be obtained by improving sail balance. Bear in mind the following important points:-

- Do not allow the yacht to heel excessively.
- Ease the mainsheet traveller to leeward to reduce heeling and weather helm.
- If necessary reef the mainsail a little early.

It is also advisable whenever possible to avoid sailing with the wind dead astern in very strong winds and large seas.

Ideally, the wind should be brought at least 30° away from a dead run and in severe conditions it may be advisable to remove the mainsail altogether and sail under headsail only. Providing these simple precautions are taken the autopilot will be able to maintain competent control in gale force conditions.

Passage making under automatic pilot is a very pleasant experience which can lead to the temptation of relaxing permanent watch. This must always be avoided no matter how clear the sea may appear to be.

Remember, a large ship can travel two miles in five minutes – just the time it takes to make a cup of coffee!

TOTE BAG (Cat No. D089)

A special zip top padded bag made from tough PVC is available to protect and stow your Autohelm and is available from Autohelm stockists.

Warning

- Do not stow your Autohelm in a locker liable to flooding by bilge water.
- Do not leave your Autohelm in a locker over the winter lay up period.

MAINTENANCE

All moving parts of the system have been lubricated for life at the factory. Therefore no maintenance whatsoever will be required. Should a fault develop,

the entire unit should be returned, in the original packing case for repair and servicing, which will be carried out speedily and at a moderate cost.

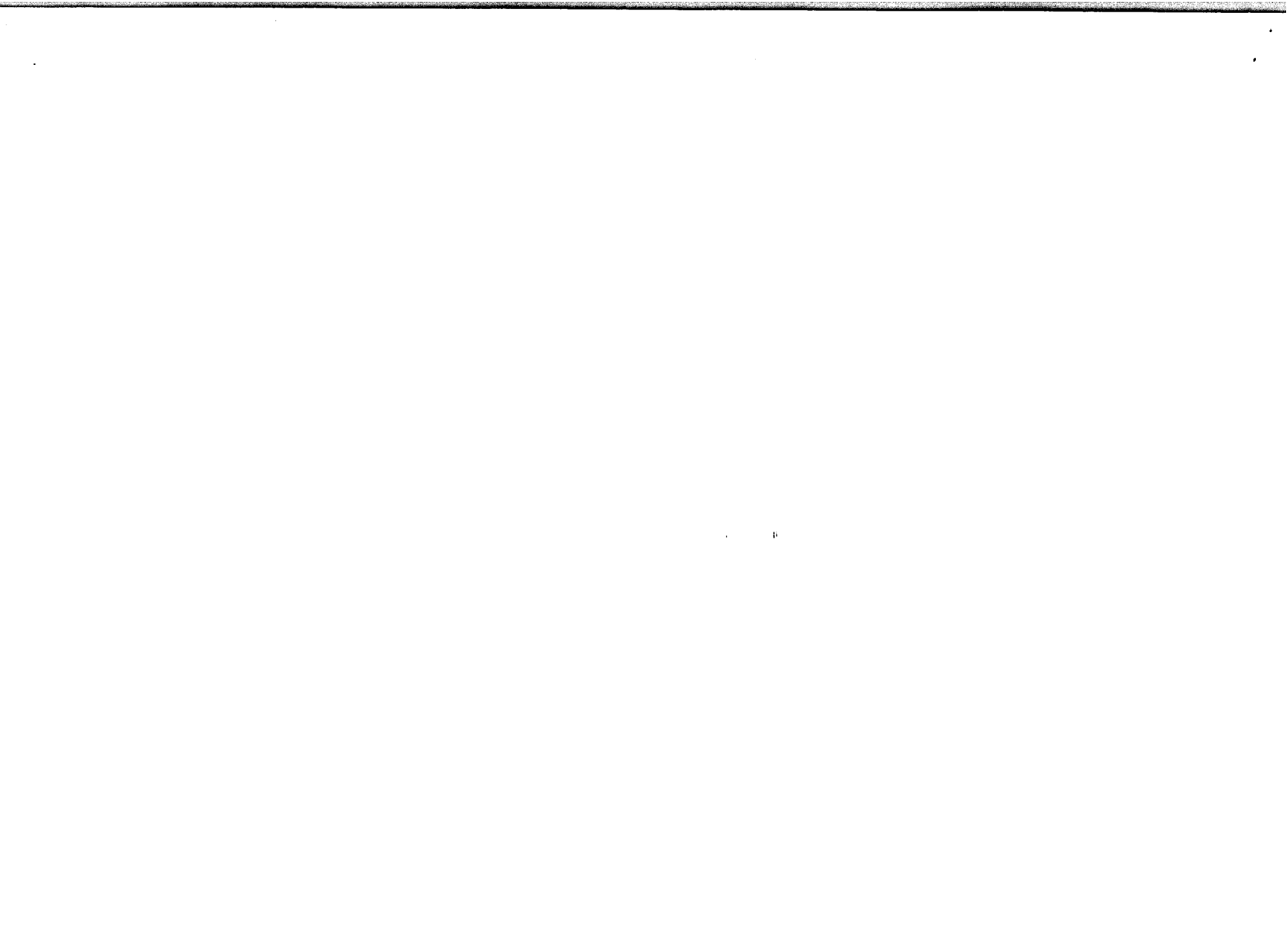

WARRANTY

LIMITED WARRANTY

Nautech or its appointed Distributors or Service Centres will, subject to the conditions below, rectify any failures in this product due to faulty manufacture which become apparent within two years of its purchase date.

Equipment used in the country of purchase should be sent directly to the authorised Distributor for that country or its appointed Service Centres. The product will then be serviced free of charge and returned promptly direct to the sender.

Equipment used outside the country of purchase can be either:-

- Returned to the Distributor or Dealer in whose country or from whom the equipment was originally purchased - it will then be serviced free of charge and promptly returned direct to the sender, or

- The product can be returned freight pre-paid to the authorised Distributor or its appointed Service Centres in the country in which the product is being used. It will then be serviced and returned direct to the sender on the basis that the Distributor or Service Centre will supply any parts used free of charge but the sender will be invoiced for the necessary labour and return shipment at the local rate.

CONDITIONS

The warranty is invalid if:-

- The product has been misused, installed or operated not in accordance with the standards defined in this manual.
- Repairs have been attempted by persons other than Nautech approved Service personnel.

AFTER SALES SERVICE

Should for any reason your Autohelm require attention ensure that you return it to one of our Authorised Service Centres. You will find a list enclosed.

Each service centre is trained and equipped to provide expert attention to your Autohelm.

SERVICE CENTRES - UK, Eire and Channel Islands

 **Factory Service**
Nautech Ltd
Anchorage Park
Potsmouth
Hampshire
0705 693511

 **Portsmouth/Chichester Harbour**
Greenham Marine Ltd
Emsworth Yacht Harbour
Thorney Road
Emsworth
Hampshire
0243 378314

Pennant Marine
Chichester Marina
Chichester
West Sussex
0243 511070

 **Hamble River/ Southampton Water**
B K Electro Marine
Stone Pier Yard
Stone Road
Warsash
Hampshire
048 95 2170

Hudson Marine Electronics
Mercury Yacht Harbour
Satchell Lane
Hamble
Hampshire
0703 455129

 **Isle of Wight**
Lecmar Marine Electronics
Avastia Marine
Coates
RISV
0783 293925

 **Lymington/Poole**
Greenham Marine Ltd
King Salmons Lane
Lymington
Hampshire
0530 75771

Dantea Electronics
C44A Quay
Poole
Dorset
0202 673899

Greenham Marine Ltd
Osney West Marina
21 West Quay Road
Poole
Dorset
0202 676763

 **Devon**
Burwin Marine Electronics
Edwin Street
Salcombe
054894 3321

Greenham Marine Ltd
Watersports Centre
Queen Anne Battery
Conise
Plymouth
0752 228114

Marine Electronics Systems
Pudidge
Buckland Brewer
Bideford
North Devon
0805 22870

Ocean Marine Services
43 Bretonside
Plymouth
0752 23922

Quay Electrics (Teignmouth) Ltd
The Sail Loft
Pump Street
Brixham
08045 3030

 **Cornwall**
Mylor Marine Electronics
Mylor Yacht Harbour
Falmouth
Cornwall
0326 74001

 **Severn & Bristol Channel**
A N D Electronics
Unit 302
Vene Road
Sevenside Trading Estate
Avonmouth
Bristol
0272 821441

 **South Wales**
Cavios Instrumentation Ltd
Linn Way
Enterprise Park
Llansanel
Swansea
0792 297878

Dale Sailing Co Ltd
Dale
Haverford West
Dyfed
04565 349

 **North & West Wales**
Rowlands Marine Electronics Ltd
The Osler Harbour
Fynhoi
0758 613193

Sailtrim Marine
Church Street
Glan Ceunynn
Colwyn Bay
Clwyd
0492 48536

 **Merseyside**
Robbins Marine Radio Services
North East Coburg Dock
Liverpool
051 8075431

 **Lancashire**
John H Jones Ltd
Marine Electronics Services
190 Dock Street
Fleetwood
03917 5241

 **Northern Ireland**
Bellfast Lough Marine Electronics
55 Bellfast Road
Carrickfergus
Co Antrim
09603 65565

 **Eire**
A E Brunker
211 Chalkwell Park
Dunelm II
0001 342574
Rider Services
Glentworth
Passage West
Co Cork
010 353 2181 1176

 **Isle of Man**
Devan Ltd
Stearns Hotel Building
East Quay
Ramsey
Isle of Man
0624 812583

 **SW Scotland**
Boat Electrics & Electronics
145 Temple Hill
Trenton
Ayrshire
0232 315355

 **Western Scotland**
Jell Rutherford
Yacht Electrical and
Electronic Services
Largs Yacht Haven
Largs Road
Largs
Ayrshire
0175 486091

 **Northern Scotland**
B P Instrumentations Ltd
Greenbank Road
East Lothian
Aberdeen
0224 874001

 **Shetland Isles**
H Williamson & Sons (Scalloway) Ltd
Main Street
Scalloway
Shetland
0197981 645

 **S/E Scotland**
Forth Area Marine Electronics
Electronic Centre
Port Edgar
South Queensferry
Edinburgh
031 331 4331