

FURUNO

SERVICE MANUAL

Class B AIS Transponder

MODEL **FA-50**



ECF

(Elemental Chlorine Free)

The paper used in this manual
is elemental chlorine free.

FURUNO ELECTRIC CO., LTD.

9-52 Ashihara-cho,
Nishinomiya, 662-8580, JAPAN

Telephone : +81-(0) 798-65-2111

Fax : +81-(0) 798-65-4200

• FURUNO Authorized Distributor/Dealer

All rights reserved.

Printed in Japan

A : OCT. 2009

Pub. No. SME-44420-A

(NAYO) FA-50



* 0 0 0 1 7 2 1 6 8 1 0 *

Summary

1. Password	1
2. Method of Connecting FA-50 to PC and Access Method	1
3. Sensor Connection	1
4. Comparison between Class A and B.....	1
5. Diagnosis	2
6. Action of after Board Replacement	5
7. Menu Tree.....	6

Chapter 1. Overview

1.1 Overview	1-1
1.1.1 System Configuration	1-1
1.1.2 Equipment List	1-2
1. Standard Supplies	1-2
2. Option Supplies.....	1-3
1.1.3 Applications	1-4
1.1.4 Opening Web browser screen of FA-50	1-4
1.1.5 Connecting External Display	1-7
1. Example of NavNet 3 Connection	1-7
2. Example of FR-8xx2 Series Radar Connection.....	1-8
3. Example of FR-2xx7 Series Radar Connection.....	1-12
1.2 Overview of AIS Class B System.....	1-13
1.2.1 Comparison between Class A and B (CS).....	1-13

Chapter 2. Initial Setup

Introduction.....	2-1
2.1 COM Port Setup	2-2
1. J14: Jumper Setup	2-3
2. COM Port Setup.....	2-4

2.2 Network Setup.....	2-5
2.3 Ship Static Setup.....	2-8
2.4 Own Vessel Data.....	2-11
2.4.1 Own Static.....	2-11
2.4.2 View Channel.....	2-12
2.5 Message.....	2-15

Chapter 3. Parts Location

3.1 FA-50.....	3-1
3.2 GVA-100: Combined Antenna.....	3-6

Chapter 4. Menu Tree

4.1 Web browser Screen.....	4-1
-----------------------------	-----

Chapter 5. Block Diagrams

5.1 System Configuration.....	5-1
5.2 Block Diagrams.....	5-3
5.2.1 General.....	5-3
5.2.2 RX1, 2 Boards (05P0808A, B).....	5-4
1. RX1 Board (05P0808A).....	5-4
2. RX2 Board (05P0808B).....	5-5
5.2.3 MAIN&TX Board (05P0814).....	5-7
1. MAIN Circuit.....	5-7
2. TX Circuit.....	5-9
3. SW REG Circuit.....	5-10
5.2.4 PWR Board (05P0809).....	5-11

Chapter 6. Updating Program

6.1 Updating Program	6-1
6.1.1 Preparation of Update	6-1
1. Connections	6-1
2. Program files	6-1
6.1.2 Procedure.....	6-2
Reference 1: When the program update is failed	6-5
Reference 2: Procedure to update when HUB is not available	6-6
6.1.3 After updating	6-7
1. Execute Memory Clear.....	6-7
2. Check the Program Version	6-8

Chapter 7. Measurement

7.1 Overview	7-1
7.1.1 Connecting Measurement Devices.....	7-1
7.2 Measurement of Tx Output Power and Frequency.....	7-2
7.2.1 Transmission Control from Web browser Screen	7-2
7.2.2 Transmission Control by S2 on MAIN&TX Board	7-5
7.3 Tx Output Power Adjustment.....	7-6
7.3.1 Tx Output Power Adjustment.....	7-6
7.3.2 Tx Frequency Adjustment.....	7-6

Chapter 8. Maintenance

8.1 For Service	8-1
8.1.1 Version	8-2
8.1.2 NMEA.....	8-3
1. Output VDM	8-4
2. Output VOD	8-5
3. Sentence without checksum	8-5
4. EPFS Alarm	8-6
5. L/L, SOG, COG Alarm	8-6

6. HDG Alarm.....	8-6
7. External GNNS.....	8-7
8.1.3 Demo.....	8-8
8.1.4 Cast Type	8-10
1. Broadcast.....	8-10
2. Unicast	8-10
8.1.5 Device Test.....	8-11
1. TX Test.....	8-11
2. Rx Test (Loop Back).....	8-11
3. Receive Test.....	8-12
4. RSSI Test	8-12
5. COM Port Test.....	8-13
8.1.6 IO Monitor	8-14
8.1.7 Memory Clear.....	8-15
1. Factory Rest without IP Address	8-15
2. Factory Reset.....	8-15
8.1.8 Channel.....	8-16
1. RX1	8-16
2. RX2	8-16
3. TRX Mode.....	8-17
4. TX Power:2W/1W/0W	8-18
5. Channel Selection: Auto/Manual	8-18
6. DSC Time Sharing	8-18
8.1.9 Internal GPS.....	8-19
8.1.10 Edit Message	8-19
8.1.11 Other	8-20
1. Silent Mode	8-20
2. Channel Selection	8-20
8.2 Alarm Status	8-21
1. TX (Tx malfunction)	8-22
2. CH1 (Rx channel 1 malfunction)	8-22
3. CH2 (Rx channel 2 malfunction)	8-22
4. EPFS (External EPFS lost)	8-22
5. L/L (No sensor position in use)	8-22
6. SOG (No valid SOG information)	8-22
7. COG (No valid COG information)	8-22

8. HDG (Heading lost/invalid)	8-22
8.3 Sensor Status	8-23
8.4 Tests	8-24
8.4.1 Transponder Test.....	8-24
1. Version	8-24
2. CPU1 RAM	8-24
3. CPU2 RAM	8-25
4. ROM.....	8-25
5. RX1	8-25
6. RX2	8-25
7. TX	8-25
8.4.2 GPS Test	8-25
1. Version	8-26
2. ROM.....	8-26
3. RAM	8-26
4. Antenna	8-26
8.5 DIP Switches and LEDs	8-27
8.5.1 DIP Switches	8-27
8.5.2 LED	8-28
1. Panel LEDs	8-28
2. NETWORK port LEDs	8-28

Chapter 9. Q&A

Q1. Can messages be exchanged between Class A and B system?.....	9-1
Q2. What are differences between Class A units and Class B (CS) device?.....	9-1
Q3. How are the report messages handled?.....	9-1
Q4. Service area?	9-1
Q5. Is it possible to receive a DSC distress alert?.....	9-1
Q6. Is DSC reception continuously performed?	9-1
Q7. Is there any method to set the unit to receive-only?	9-1
Q8. Is the tanker mode available?.....	9-2
Q9. In the Demo mode, is the own ship position data required?	9-2

Q10. Is it required to connect with the external sensors of
for example, the external GPS?9-2

Q11. Is it required to connect with the HDG data input?9-2

Q12. Is it allowed to use the combined antenna of FA-150?9-2

Q13. How much is the power source voltage?9-2

Q14. What is a password?9-2

Q15. How to connect to the Radar.9-2

Q16. How to setup the connection between FA-50 and NAVNET 3.9-3

Q17. Although HDG data has not been inputted to the FA-50, HDG data is
displayed on the FA-50 screen after connecting to NAVNET 3.9-3

Q18. Although the IP address is entered in the URL field,
the Web browser screen of FA-50 does not appear.....9-3

Q19. What are the values of the allowable error of
Tx power output and the frequency deviation?9-3

Q20. Where is the adjustment of Tx output power made?.....9-3

Q21. Is there any simple way to measure the sensitivity on SSG?9-3

Q22. Only few targets can be received. How to check this problem?.....9-4

Q23. Is it allowed to common use of the “Rx A” and “Rx B” ?.....9-4

Q24. About the panel LED indicators.9-4

Q25. What is the red switch on the MAIN&TX board for?9-4

Q26. Is there any method to cease External EPFS ALM?9-4

Q27. How to do a program update.9-4

Q28. Is it allowed to edit a short message?9-4

Q29. The HDG data inputted from the COM port is not accepted.9-5

Q30. Abnormal operations are observed.9-5

Q31. What settings are required to be set by a user?9-5

Q32. What items are required to be checked?9-5

Q33. No AIS data is displayed.9-5

Q34. About requirements for transmission.9-5

Q35. How to confirm that the external GPS data has been inputted.9-5

Q36. Does the reporting rate change immediately following
a change of the ship speed?9-5

Q37. What conditions should be met when using the external GPS?9-6

Appendix 1. SpecificationsAP1-1**Appendix 2. Channel Lists.....AP2-1**

1. International Mode ChannelAP2-1

2. USA Mode Channel.....AP2-3

Appendix 3. Class B AIS (CS) System

AP3.1 Overview of Class B (CS)AP3-1

AP3.1.1 Differences between Class A and Class B.....AP3-1

1. Dynamic Data.....AP3-1

2. Static Data.....AP3-2

3. Transmitting Short Messages.....AP3-2

4. Initialization Report.....AP3-2

5. Packet Format.....AP3-3

6. Carrier Sense (CS) DetectionAP3-3

7. Reporting Method.....AP3-4

AP3.2 VDL MessagesAP3-5

AP3.3 Configurations of Transmission MessagesAP3-6

AP3.3.1 Message 14AP3-6

AP3.3.2 Message 18AP3-6

AP3.3.3 Message 24AP3-8

AP3.3.4 Message 23AP3-9

AP3.4 Regional operating areaAP3-11

AP3.4.1 Channel ManagementAP3-11

AP3.4.2 Assigned AreaAP3-13

AP3.4.3 Quiet AreaAP3-15

Appendix 4. IEC61162 Sentences

AP4.1 List of IEC Sentences used in FA-30/50/150	AP4-1
AP4.2 Handling of Sentences.....	AP4-2
AP4.2.1 Overview	AP4-2
1. Handling of messages.....	AP4-2
2. Comparisons on Input Data among FA-30/50 and FA-100/150	AP4-2
AP4.2.2 Input Data Processing	AP4-3
1. Processing at Reception Error	AP4-3
2. Checking Method for Validity of Sentence	AP4-3
3. Handling of Checksum Field	AP4-3
4. Handling of Timeout.....	AP4-3
5. Priority of Talker	AP4-3
6. Handling of Positioning Status	AP4-4
7. Priority Processing	AP4-4
8. Number of decimal places in the sentence when converting to the storage data	AP4-4
9. Sentences of from LAN, COM port in Common Use	AP4-4
10. Priorities of Ports.....	AP4-4
11. Correlation between NMEA Ver. and Sentence	AP4-5
AP4.2.3 Output Sentences.....	AP4-6
1. List of Output Sentences.....	AP4-6
2. Comparisons on Output Data among FA-30/50 and FA-100/150	AP4-6
AP4.3 Sentence Description.....	AP4-8
<u>ABK</u> Addressed and binary broadcast acknowledgement	AP4-8
<u>ABM</u> Addressed Binary and safety related Message	AP4-9
<u>ACK</u> Acknowledgement alarm	AP4-9
<u>AIR</u> AIS Interrogation Request	AP4-10
<u>ALR</u> Set alarm state	AP4-11
<u>BBM</u> Broadcast Binary Message	AP4-11
<u>DTM</u> Datum reference	AP4-12
<u>GBS</u> GNSS Satellite fault detection	AP4-12
<u>GGA</u> Global positioning system fix data	AP4-13
<u>GLL</u> Geographic position, latitude/longitude	AP4-14
<u>GNS</u> GNSS fix data	AP4-14
<u>HDT</u> Heading true	AP4-15

<u>OSD</u>	Own ship data	AP4-15
<u>RMC</u>	Recommended minimum specific GNSS data	AP4-16
<u>SSD</u>	Ship Static Data	AP4-16
<u>TXT</u>	Text transmission	AP4-17
<u>VBW</u>	Dual ground/water speed	AP4-17
<u>VDM</u>	VHF Data Link Message	AP4-18
<u>VDO</u>	VHF Data Link Own-vessel message	AP4-18
<u>VSD</u>	Voyage Static Data	AP4-19
<u>VTG</u>	Course over ground and ground speed	AP4-19

<i>Parts List</i>	<i>E-0</i>
--------------------------------	-------------------

<i>Contents of Drawings</i>	<i>S-0</i>
--	-------------------

This page is intentionally left blank.

1. Password

To recall the “Ship Static Edit” menu and the “For Service” menu, Login Name and Password are required. For each menu, a combination of different Login Name and Password is required. For details, see Furuno Information: FQ4-2009-014.

2. Method of Connecting FA-50 to PC and Access Method (2-5)

Start up Internet Explorer (IE) and enter the IP address of FA-50 in the URL field; then the Web browser screen of FA-50 is displayed.

Make sure that the IP address of the PC to be connected must be set as described below:

Network Setup Default Values for FA-50

IP Address	: 172.31.024.003
Subnet Mask	: 255.255.000.000
Gateway Address	: 000.000.000.000

Tip:

If the network settings above are valid on the FA-50,

IP Address of the PC used : 172.31.024.010, for example.

Subnet Mask : 255.255.000.000

Gateway Address : 000.000.000.000

3. Sensor Connection

The built-in GPS must be installed as a requirement. Transmission cannot initiate until the built-in GPS determines positions.

The external GPS is optional so that it is not used before the built-in GPS determines positions.

The heading data (HDT) is also optional.

ROT is not defined in the list of Class B report messages and not required to be connected.

4. Comparison between Class A and B (1-13)

	FA-50 (Class B)	FA-150 (Class A)
Communication method	CSTDMA	SOTDMA
Static data	MSG.24A, B	MSG.5
Dynamic data	MSG.18	MSG.1, 2, 3
Short message	MSG.14 (a safety related message directing to all vessels, containing 16 characters at maximum)	MSG. 6, 8, 12, 14
Reporting interval	<ul style="list-style-type: none"> • Dynamic data: <ul style="list-style-type: none"> SOG ≥ 2kt: 30 seconds SOG ≤ 2kt: 3 minutes • Static data: 6 minutes 	<ul style="list-style-type: none"> • Dynamic data: 2 seconds to 3 minutes (depending on SOG) • Static data: 6 minutes

5. Diagnosis

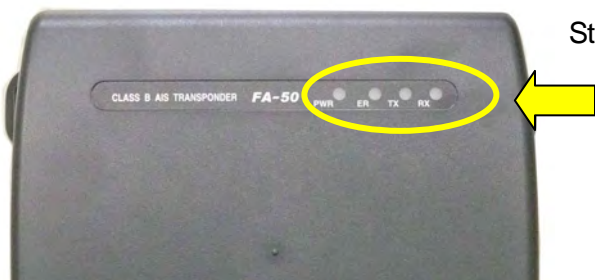

Status check



LAN connection check

Problem	Symptom and check items	Reference	
Conne- tion to PC	1) LAN connection is not allowed. Check that a cross cable is used as the LAN cable.		
	2) LAN connection is not allowed. On the NETWORK port, normally, the right LED blinking and the left LED lights up. If these LEDs indicate differently, the MAIN&TX board should be replaced.		
	3) When the IP address of FA-50 contains the default value After setting the IP address of FA-50 with a value of 172.31.24.3 and the IP address of PC with a value of, for example, 172.31.24.10, start up Internet Explorer and enter http://172.31.24.3/ in the URL field. * Subnet Mask: 255.255.0.0, Gateway: 0.0.0.0	1-5	
	4) When the IP of FA-50 has been changed and unknown; After power off, set the S4-#2 to the ON position on the MAIN&TX board and power on; then, power off and set the S4-#2 to the OFF position. This restores the Network settings in "Initial Setup" to the default values. Repeat the steps described above starting from 1) to check the LAN connection.	8-27	
Commu- nication range	If the communication range is short, check the items in Reception failure and Transmission failure described below. Depending on the antenna heights installed on the ships in communication, it is assumed to be around 10 nm, 30 nm for Class A.	1-13	
Panel LEDs	PWR	Lights up in green: Lights up at power ON, normal state.	3-1 8-28
	ER	Lights up in red: Lights up when an error in ROM/RAM or the transmit circuit is detected. The MAIN&TX board must be replaced.	
	TX	Lights up in blue: Lights up during transmission, normal state. - Blonking in orange: Tx timeout. If rebooting cannot solve the problem, the MAIN&TX board must be replaced. (Check the items in Transmission failure described next page.) - Lights up in orange: Unregistered MMSI. From Initial Setup, make the settings of Ship Static.	
	RX	Lights up in yellow: Lights up at reception. If not light up, check the items in Reception failure described next page.	

Problem	Symptom and check items		Reference
Power supply failure	Check the power source voltage.	Power source voltage should be between +10.8 to +31.2 VDC.	5-11
	Check the fuse.	The fuse mounted on the MAIN&TX board. (midget fuse: 125V/4A)	3-2
Reception failure	1. Only few targets can be received. Reception is not allowed.	Antenna replacement. 1) Check the antenna, coaxial cable/connector. The connector must be waterproofed. 2) Check the coaxial cable/connector connected on the FA-50.	
	2. Only few targets can be received.	Perform the following steps: For Service -> Device Test -> RX Test (Loop back). Any RX boards indicating NG must be replaced.	8-11
		Select Tests -> Transponder to run the test. Any RX boards indicating NG must be replaced.	8-24
		In Own Vessel Data, check the current operation channel. If a wrong channel is used, set the correct operation channel. Tips: If you are in Regional operating area, select For Service -> Channel and change the Mode setting to Manual; then set an Regional operation frequency for that area to be able to receive the Regional operation area data. The MODE setting must be reset to Auto afterward.	2-12
Transmission failure	Transmission is not allowed.	If the Silent menu is displayed on the TOP page of the Web browser screen, select Silent and change to Normal.	8-20
		Measure the Tx output power. If no Tx output is measured, the MAIN&TX board must be replaced.	7-2
		Check if the built-in GPS determines positions. If not, no transmission can be conducted.	
	Too low Tx output power.	Measure the Tx output power. If the specified output value is not obtained, make an adjustment of Tx output power. If the specified output value is not yet obtained after the adjustment, the MAIN&TX board should be replaced.	7-2
		Antenna replacement. 1) Check the antenna, coaxial cable/connector. The connector must be waterproofed. 2) Check the coaxial cable/connector connected on the main unit.	
Too large frequency deviation.	If it is more than ± 500 Hz, the MAIN&TX board must be replaced.		

Problem	Symptom and check items		Reference
GPS	Reception disabled.	Select Tests and run the GPS test. If any NG items are found, the MAIN&TX board must be replaced. Check that the voltage of 5 VDC is applied on the GPS antenna terminal. If not applied, the MAIN&TX board must be replaced.	8-25
	Frequently lost.	Antenna replacement. 1) Check the antenna, coaxial cable/connector. Note that no water leakage is observed on the connector. 2) Check the coaxial cable/connector iconnected on the main unit. Tip: To monitor the GPS data, select For Service -> IO Monitor -> GPS.	
ALM	EPFS alarm	If no external GPS is connected, select For Service -> NMEA -> EPFS Alarm and set it OFF.	8-3
		If the external GPS is connected via the COM port, select For Service -> Device Test and run the COM Port Test. If NG, the MAIN&TX board must be replaced. (Before starting the test, make a jumper connection between TX and RX data in the COM port.)	8-13
	The acceptable sentences are the following: GNS, GLL, GGA, RMC, VBW, VTG, OSD	8-14 AP4-1	
	L/L, SOG, COG alarms	Check the GPS. Tip: To monitor the GPS data, select For Service -> IO Monitor -> GPS.	8-6 8-14 8-21 8-25
	HDG alarm	If the HDG data is connected via the COM port, select For Service -> Device Test and run the COM Port Test. If NG, the MAIN&TX board must be replaced. (Before starting the test, make a jumper connection between TX and RX data in the COM port.)	8-13
The acceptable sentence is HDT. If no HDG data is connected, select For Service -> NMEA -> HDG Alarm and set it OFF.		AP4-1 8-3	

6. Action of after Board Replacement

Board	Action
RX1(05P0808A)	No settings required. Perform the following steps: For Service -> Device Test -> RX Test (Loop back) and determine whether reception is normally conducted. This can be determined by checking the number of targets.
RX2(05P0808B)	No settings required. Perform the following steps: For Service -> Device Test -> RX Test (Loop back) and determine whether reception is normally conducted. This can be determined by checking the number of targets.
MAIN&TX (05P0814)	<ol style="list-style-type: none"> 1) The steps: Initial Setup -> Ship Static Edit must be completed. 2) ER LED (red) on the panel should light off. 3) Follow the steps: For Service -> Test. 4) Check if the Internal GPS determines positions. 5) Check that reception is normally conducted. Check the expected number of targets. 6) Check that transmission is normally conducted. During transmission, TX LED on the panel should light up in blue.
PWR(05P0809)	No settings required. Check if the board normally turns on.

7. Menu Tree

For details, refer to Chapter 4.

The numbers shown under the items respectively indicate the corresponding page numbers.

Top Menu

<p>Initial Setup</p>	COM Port (2-2)	Data Type TX Speed RX Speed	<p>For Service</p>	Version (8-2)	Version CPU 1 CPU 2 FPGA	
	Network (2-5)	MAC Address IP Address Subnet Mask Gateway Address NavNet Port Number Host Name AIS Data Output		NMEA (8-3)	Output VDM Output VOD Sentence without checksum EPFS Alarm L/L, SOG, COG Alarm HDG Alarm External GNNS	
	Ship Static (2-8)	MMSI Ship Name Call Sign Internal Antenna Position External Antenna Position Ship Type		Demo (8-8)	Off TOKYO OSAKA	
	Own Vessel Data	Own Static (2-11)		MMSI Ship Name Call Sign Internal Antenna Position External Antenna Position Ship Type Cargo Type Cargo Type Edit	Cast Type (8-10)	Broadcast Unicast Post IP
					View Channel (2-12)	RX1 RX2 Power Region List Group Assignment
					Message	Send Message (2-15)
		TX Log (2-16)		No Date Time CH Message Flag	Device Test (8-11)	TX Test Rx Test(Loop Back) Receive Test RSSI Test COM Port Test
		RX Log (2-17)		No Date Time MSG CH MMSI Text Flag Detail	IO Monitor (8-14)	COM NavNet PCMKD GPS Refresh
	Alarm Status (8-21)	Type UTC Description			Memory Clear (8-15)	Factory Rest without IP Address Factory Rest
	Sensor Status (8-23)				Channel (8-16)	RX1 RX2 TRX Mode TX Power Channel Selection DSC Time Sharing
Tests	Transponder Test (8-24)	Version CPU1 RAM CPU2 RAM ROM RX1 RX2 TX	Internal GPS (8-19)	LAT LON SOG/COG MODE/STATUS RAIM/PA UTC		
	GPS Test (8-25)	Version ROM RAM Antenna	Edit Message (8-19)	Message Select Edit Message		
Silent (Silent Mode) (8-20)	Normal Silent		Other (8-20)	Silent Mode Channel Selection		
Tx Power (Tanker Mode) (2-10)	Normal 1W					

1.1 Overview

1.1.1 System Configuration

The FA-50 is a Class B AIS device using CSTDMA (Carrier Sense TDMA) technology developed for Non-SOLAS ships.

CSTDMA is a communication method where Class A AIS signals are monitored and, if no signal is detected, a transmission starts.

The FA-50 transmits static and dynamic data of the own ship to other ships reported with Class A, B AIS or coastal station nearby and also receives signals from Class A, B AIS.

Furthermore, it can display and process the AIS information received using a PC software program (PC-MKD) included as standard. By connecting with Radar such as FR-8002, or NAVNET-3, displaying AIS information is surely available.

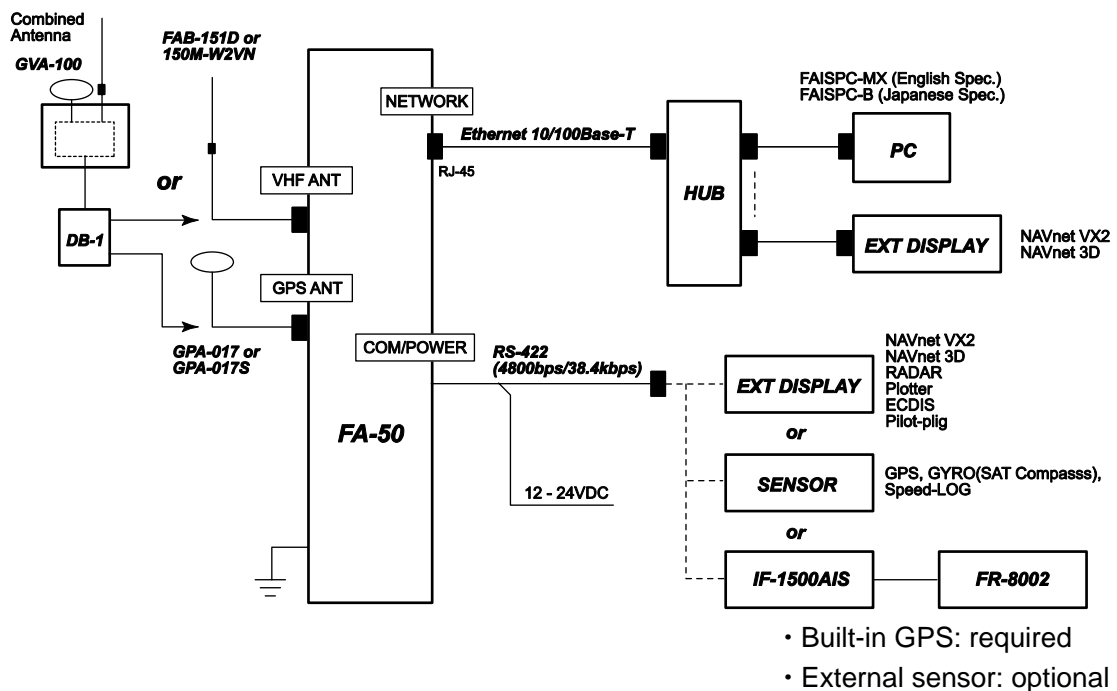

Figure 1.1.1 System Configuration Diagram of FA-50

Tips:

Class B AIS system has two types, CSTDMA and SOTDMA (Class A).

In the CSTDMA system, it monitors Class A AIS signals and, if an open slot is found, broadcasts its position data and own ship data.

In the SOTDMA system (Self-Organizing Time Division Multiple Access), reporting message is broadcasted in synchronization with UTC.

The FA-50 using CSTDMA system that is less expensive and suitable for smaller ships.

1.1.2 Equipment List

1. Standard Supplies

Table 1.1.1 Standard Supplies

Name	Type	Code No.	Qty	Remarks
AIS transponder	FA-50	-	1	
Antenna unit	GVA-100	-	1	GPS/VHF combined
	GPA-017S	-	1 set	GPS antenna
	GPA-017	-	1 set	GPS antenna with 10 m cable
Distributor	DB-1		1	For GVA-100
Installation materials	CP24-00502	005-955-560	1 set	For GPA-017S
	CP05-11401	001-031-970	1 set	For FA-50, self-tapping screws (Type: 4x20, Code No.: 000-158-850-10)
	TNC-PS/PS-3D-L15M-R	000-133-670-11	1	For GPA-017S, 15 m cable
	CP24-00101	005-950-730	1 set	For DB-1, self-tapping screws (Type: 4x30, Code No.: 000-162-659-10)
Accessories	FP05-06110	000-166-648	1 set	FAISPC-MX for PC
Spare parts	SP05-05801	001-031-960	1 set	4A fuses (Type: FGMB 125V 4A, Code No.:000-157-482-10)

2. Option Supplies

Table 1.1.2 Option Supplies

Name	Type	Code No.	Qty	Remarks
AC-DC power supply	PR-240-CE	-	1	
Whip antenna	CP05-11001	001-034-670	1	
Antenna cable set	CP20-02700	004-381-160	1	For GPA-017S
	CP20-02710	004-381-170	1	For GPA-017S
	CP24-00300	000-041-938	1	For GVA-100
	CP24-00310	000-041-939	1	For GVA-100
Coaxial cable	TNC-PS/PS-3 DL15M-R	000-133-670-11	1	TNC-TNC, 15 m
Right-angle antenna base	No.13-QA330	000-803-239	1	For GPA-017/S
L-angle antenna base	No.13-QA310	000-803-240	1	For GPA-017/S
Antenna base for rail mount	No.13-RC5160	000-806-114	1	For GPA-017/S
Mast mount fixture	CP20-01111	004-365-780	1	For GPA-017/S
AIS viewer	FAISPC-MX50	000-160-966	1	
LAN cable	P5E-4PTX-BL L=2M	000-164-634-10	1	2 m
	P5E-4PTX-BL L=10M	000-164-637-10	1	10 m
Cable assy	MJ-A6SPF001 7-010C	000-159-704-11	1	For NavNet VX2, 1 m
	MJ-A6SPF001 7-050C	000-159-705-11	1	For NavNet VX2, 5 m
	MJ-A6SPF001 7-100C	000-159-706-11	1	For NavNet VX2, 10 m
	MJ-A6SPF001 7-200C	000-159-707-11	1	For NavNet VX2, 20 m
	MJ-A6SPF001 7-300C	000-159-708-11	1	For NavNet VX2, 30 m

1.1.3 Applications

Application	Product Name	Remarks	
AIS viewer	MAX SEA (FAISPC-MX50)	English version (Standard supply)	Provided in the form of CD. AIS viewer software developed by MAX SEA. Needs to be installed on your PC. World-wide raster charts are included.
FA-30/50 Web browser screen operating on IE	-	Japanese/English versions	Not requiring software installation on your PC and instantly accessible from IE.

1.1.4 Opening Web browser screen of FA-50

In the Web browser screen, setup and maintenance of FA-50 can be performed. To open the Web browser screen, start Internet Explorer (IE) and enter the IP address of FA-50 in the URL field.

Note:

In the IE window, select [Tools] -> [Internet Options] -> [Connections] -> [LAN Settings] and deselect the checkbox for [Use a proxy server for your LAN]. Unless it is deselected, the Web browser screen is not displayed.

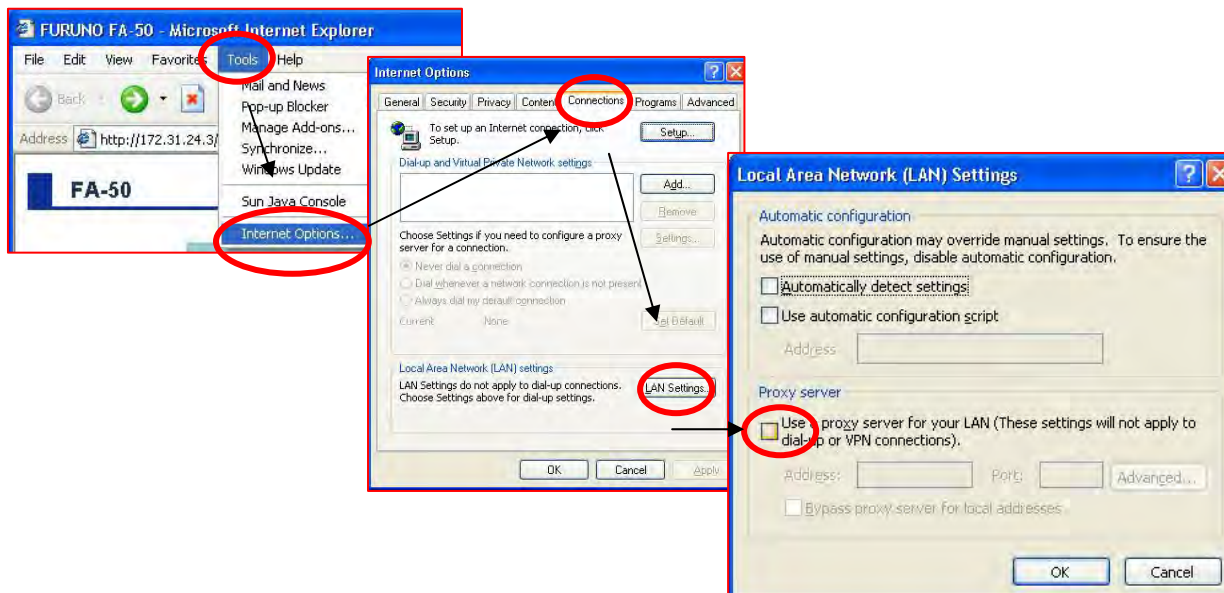

Procedures:

Connect between the PC and FA-50 via the NETWORK port.

**** Windows 2000/XP ****

1. Startup the PC and set the IP address and subnet mask of PC with the values corresponding to the network address of FA-50.
Click [My Network Places] -> [Properties] -> [Local Area Connections] -> [Properties] -> "Internet Protocol (TCP/IP)" -> [Properties] and then set the IP.

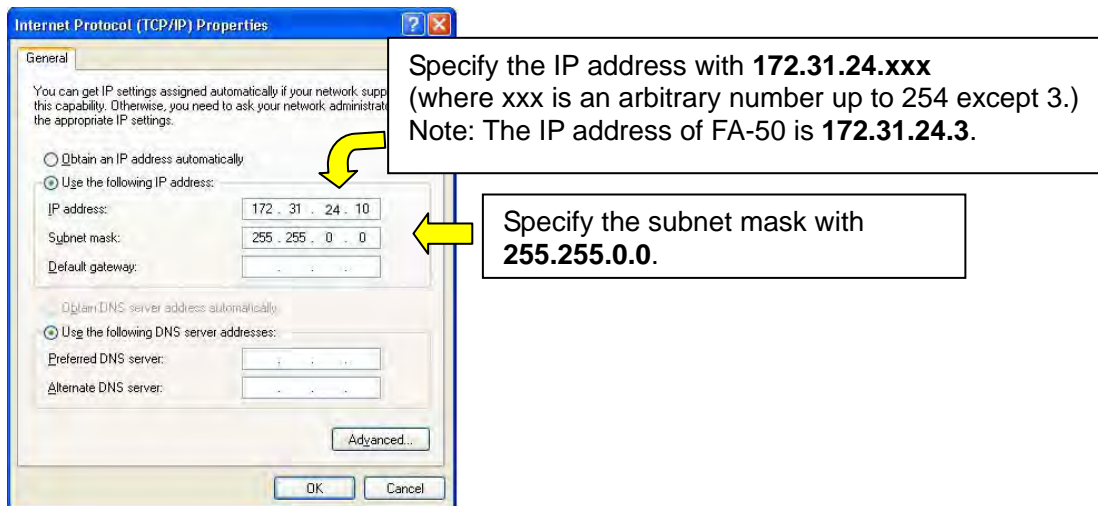

**** Windows VISTA ****

Click [Start] -> [Network] -> [Properties] -> "Control Network Connection" -> [Local Area Connections] -> [Properties] -> "Internet Protocol version4 (TCP/IPv4)" -> [Properties] and then set the IP.

2. Start the Internet Explorer (IE) and follow the steps below:
Select [Tools] -> [Internet Options] -> [General] -> "Temporary Internet Files" -> [Settings] -> "Check for newer versions of stored pages" and then place a checkmark on [Every visit to the page].

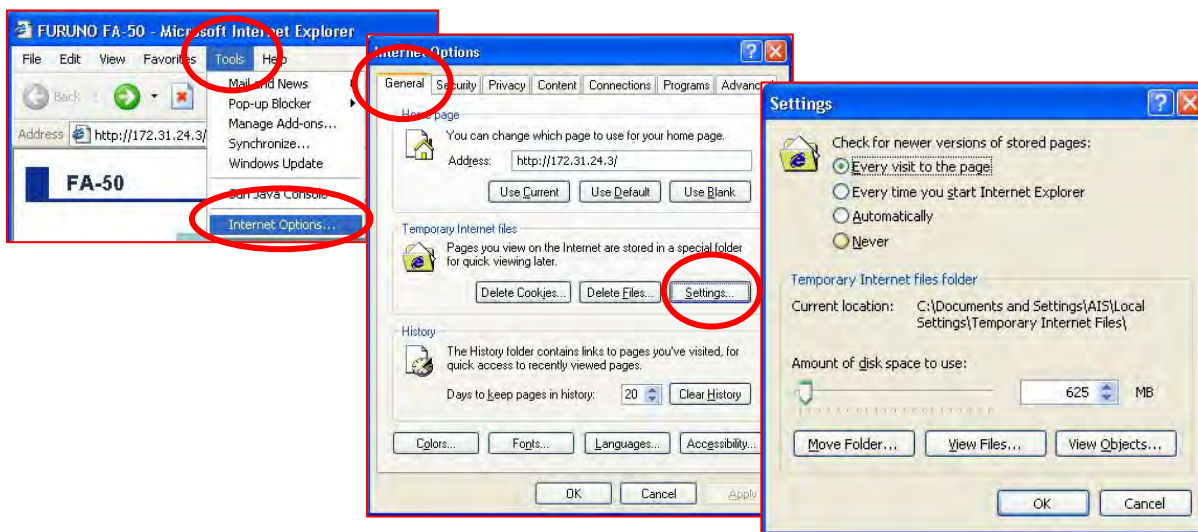

3. In the URL field in IE, enter “http://172.31.24.3” and press the [Enter] key; then the PC and FA-50 are connected and the Web browser screen opens.

Note:

“172.31.24.3” is the default value of FA-50.

- Initial Setup -> Ship Static Edit: Login Name and Password are required.
- For Service: Login Name and Password are required.

For details of Login Name and Password, refer to the Furuno information: FQ4-2009-014.



1.1.5 Connecting External Display

The external input/output ports are provided as NETWORK (RJ-45) and COM/POWER.

The NETWORK port, which complies with Ethernet 10/100 BASE-T standard, is used to connect with external AIS display devices such as NAVNET 3 and FAISPC-B (PC software) in the LAN.

The COM/POWER port is used for the power line and the I/O signal line. For use as the power source line, a 12 to 24 VDC input is connected, while an external display device, such as Radar, or sensor is connected complying with RS-422 standard, for use as the signal line.

Sensors connected to FA-50 require a built-in GPS, while external sensors for GPS data (Pos., SOG/COG) and heading are optional.

1. Example of NavNet 3 Connection

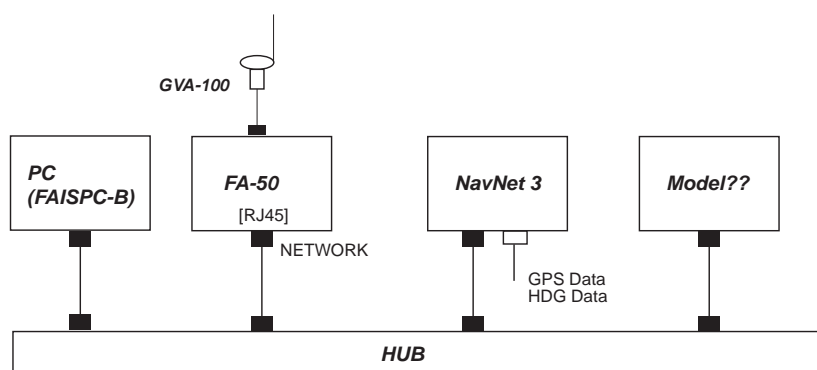

Table 1.1.3 IP Address

Setting Item	FA-50 Initial Value	PC (FAISPC-B)	NavNet 3 Initial Value
IP Address	172.031.024.003	ex; 172.031.024.010	Allocated automatically by DHCP server
Subnet Mask	255.255.000.000	255.255.000.000	255.255.000.000
Default Gateway	000.000.000.000	000.000.000.000	000.000.000.000
NavNet Port Number	10000 (10033)		10000 (10033): AIS port number
Host Name	AIS0		
AIS Data Output	Auto		

The AIS setup can be made in “Network Setup” accessed from the Initial Setup menu. For details, refer to page 2-5.

For the NAVNET 3 setup, refer to page 2-7.

2. Example of FR-8xx2 Series Radar Connection

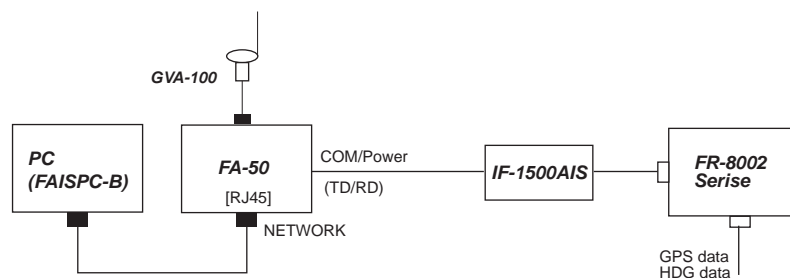

Connection between FA-50 and FR-8xx2 Series Radar should be made via IF-1500AIS. Connection between FA-50 and IF-1500AIS is based on RS-422 specifications. The FA-50 is not provided with the function for sorting AIS targets so that it is processed by IF-1500AIS.

The FA-50 setup can be made in “COM Port Setup” accessed from the Initial Setup menu. For details, refer to page 2-4.

On the Radar, input GPS data and heading data.

Connections

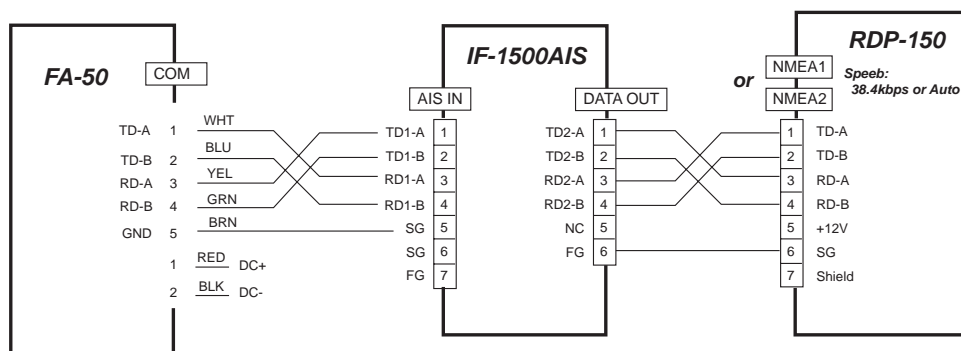

Settings

1. FA-50 Setup

Initial Setup -> COM Port Setup

- Data Type: IEC61162 •Tx Speed: 38400 bps (fixed)
- Rx Speed: Auto, or 38400 bps

J14 on the MAIN&TX board: RS-422 (Jumper block are set with 1/2/3/4.)

2. FR-8002 Series Radar Setup

To make the port setup of [NMEA1] and [NMEA2] connected with AIS, follow the steps described below:

- Select Initial Setup -> Port1 (2) -> “38400 bps” or “Auto” and
- Select Initial Setup -> Through Output -> “OFF”.

3. IF-1500AIS Setup

The port setup can be made on the internal DIP switches: S1. All switches should be set to the “OFF” position.

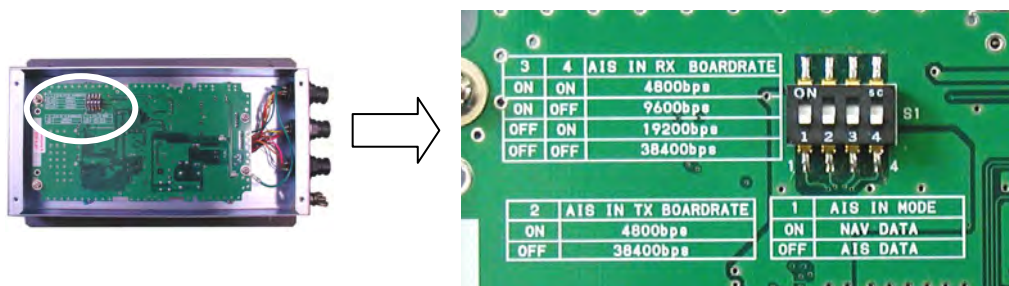

Tips:

Functions of individual DIP SW are described below. By default, all switches are set to the “OFF” position.

Table 1.1.4 Communication Speed Settings of AIS
Communication Input Port (AIS IN: RD-A/B)

DIP SW: S1		Communication Speed
#3	#4	
ON	ON	4,800bps
ON	OFF	9,600bps
OFF	ON	19,200bps
OFF	OFF	38,400bps

Table 1.1.5 Communication Speed Settings of AIS
Communication Output Port (AIS IN: TD-A/B)

DIP SW: S1		Communication Speed
#2		
ON		4,800bps
OFF		9,600bps

Table 1.1.6 Mode Settings of AIS Communication Output Port (AIS IN: TD-A/B)

DIP SW: S1 #1	Mode Selection	Remarks
ON	Navigation Data	Used for Navigation Data output The sentences (RMC, HDG, HDT, and HDM) from the FR-8002 are outputted on IF-1500AIS as they are. On FR-8002, the AIS targets can be displayed but no alarm ACK to FA-50.
OFF	AIS Data	Used for AIS transponder communication

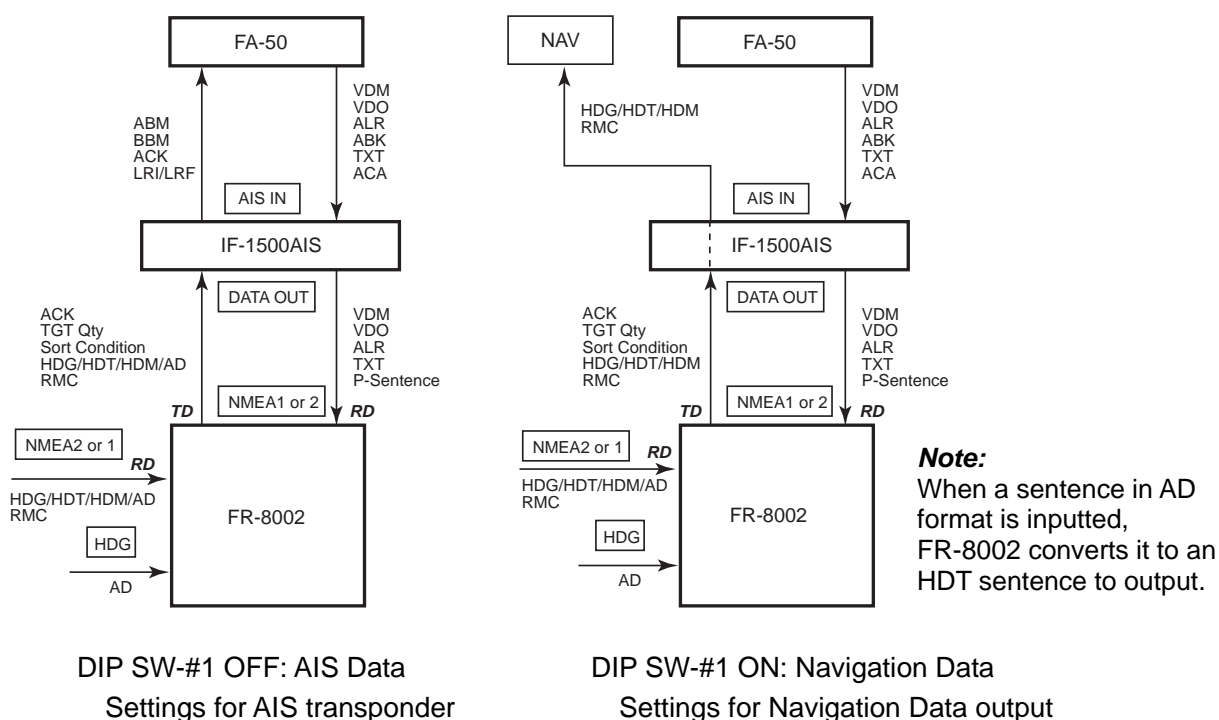

IF-1500AIS

The IF-1500AIS is an AIS interface between FA-50 and FR-8002 series Radar. It screens AIS target information: VDM inputted from FA-50, sorts the data (by distance, range, CPA, TCPA), and converts to PFEC sentences: AITtm (distance and heading of the target, CPA, TCPA, various alarm conditions) to output to FR-8002. The FR-8002 displays AIS targets based on the data obtained as described above.

Tips:

The FR-8002 is not provided with the functions for screening and sorting AIS targets, which must be processed by IF-1500AIS. The FA-150 is, however, provided with these functions so that the IF-1500AIS is not required.

Main functions (FA-50 <-> IF-1500AIS <-> FR-8002)

1. Targets sorting function

The IF-1500AIS can sort targets based on the condition, including any given values of distance or range, CPA, and TCPA in ascending or descending numeric order and output the results to FR-8002 (VDM, VDO, AITtm).

2. Own Vessel Data Output

The IF-1500AIS passes the own vessel data: VDO from FA-50. It also interfaces an alarm responding process (lost target acknowledged: ACK) between FR-8002 and FA-50.

3. AIS Information Output

The IF-1500AIS can output information of FA-50 (alarm status: ALR) to FR-8002 by request of FR-8002.

4. Alarm Function

The IF-1500AIS can detect a CPA/TCPA alarm against a sorted target and output it to FR-8002 in the form of PFEC sentence.

5. Lost Function

The IF-1500AIS performs a lost process when a lost condition occurs against a sorted target. The FR-8002 displays such conditions in the form of PFEC sentence.

6. Navigation Data output.

The IF-1500AIS can output the HDG, HDT, HDM, and RMC sentences inputted from FR-8002 as they are. To use this function, DIP SW-#1 (Mode Selection: Navigation Data) inside of the IF-1500AIS must be set to the ON position.

Note: When FR-8002 recognizes FA-150 or IF-1500AIS, HDG, HDT, HDM, and RMC data inputted on the FR-8002 are outputted to TD of the connected port.

7. Others

If no communication between FA-50 and FR-8002 can be established, the AIS menu of FR-8002 cannot open. In other words, it is a case that the IF-1500AIS "Idfunc" sentence cannot be received at an inquiry from FR-8002 to IF-1500AIS.

3. Example of FR-2xx7 Series Radar Connection

Connection between FA-50 and FR-2xx7 Series Radar should be made based on RS-422 standard.

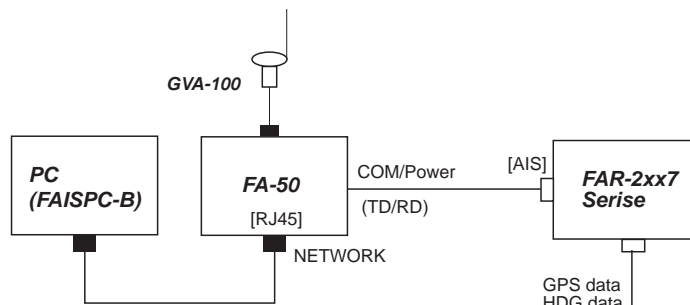

The FA-50 setup can be made in “COM Port Setup” accessed from the Initial Setup menu. For details, refer to page 2-4.

On the Radar, input GPS data and heading data.

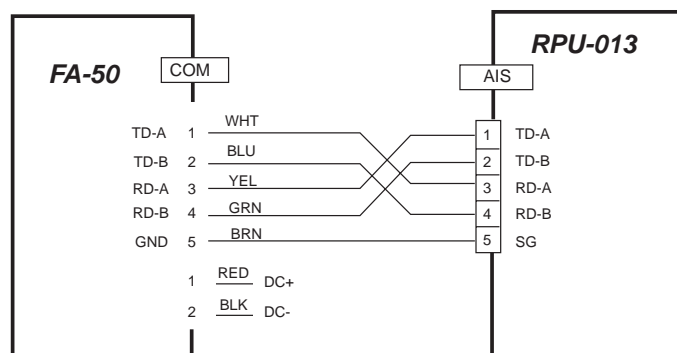

1. FA-50 Setup

Initial Setup -> COM Port Setup

- Data Type: IEC61162
- Tx Speed: 38400 bps (fixed)
- Rx Speed: Auto, or 38400 bps

J14 on the MAIN&TX board: RS-422 (Jumper block are set with 1/2/3/4.)

2. FR-2xx7 Series Radar Setup

The AIS display should be set ON.

1.2 Overview of AIS Class B System

1.2.1 Comparison between Class A and B (CS)

Table 1.2.1 Comparison between AIS Class A and B

Item	Class A	Class B (CS)
Target vessel	SOLAS vessels	Non-SOLAS vessels
Communication method	SOTDMA, RATDMA, FATDMA, ITDMA (Self Organized Time Division Multiple Access)	CSTDMA, FATDMA (Carrier Sensing Time Division Multiple Access)
Frequency range	156.025-162.025 MHz	Same as on the left
Frequency spacing	25 kHz/12.5 kHz	25 kHz
Tx output power	2/12.5 W (1 W)	2 W (1 W)
Bandwidth	16 kHz or less	Same as on the left
Speed rate	9600 bps	Same as on the left
Modulation	GMSK (Gaussian filtered Minimum Shift Keying)	Same as on the left
Number of bits per slot	256 bits	Same as on the left
Data coding	NRZI(Non Return to Zero Inverted)	Same as on the left
Transmit/receive function	<ul style="list-style-type: none"> • TDMA transmit/receive function • DSC transmit/receive function 	<ul style="list-style-type: none"> • TDMA transmit/receive function • DSC transmit/receive function (optional)
Types of Messages able to be transmitted	MSG. 1, 2, 3, 5, 6, 7, 8, 10, 11, 12, 13, 14, 15	MSG. 13, 14, 18, 19, 24
Types of Messages able to be received	All of MSG. 1-24 (0-63) Where the messages directing to other ships are excluded.	MSG. 1, 2, 3, 4, 5, 8, 9, 11, 12, 14, 15, 17, 18, 19, 20, 21, 22, 23, 24 (Where the messages directing to other ships are excluded.)
Communication range	<ul style="list-style-type: none"> • 15t o 30 nm: Ship to Ship • 60 nm: Ship to Cost 	<ul style="list-style-type: none"> • 5 to 8 nm: Ship to Ship • 20 nm: Ship to Cost
Reporting interval	Varies from 2 seconds to 3 minutes depending on the speed over ground (SOG), course change, and NAV Status. Note) Static data and Navigation-related data: basically, intervals of 6 min.	<ul style="list-style-type: none"> • SOG > 2kt: at intervals of 30 sec • SOG ≤ 2kt: at intervals of 3 min Note) Static data and Navigation-related data: basically, intervals of 6 min. (MSG. 24A and 24B)
Receiving DSC CH70	Equipped with a dedicated CH70 receiver.	Equipped with a dedicated CH70 receiver or sharing a TDMA receiver (with FA-50).
Transmitting DSC CH70	Yes	No
GPS data (Pos., SOG, COG)	Requests external and internal GPS. (WGS84)	Requests internal GPS while external GPS is optional. Note) DTM, GBS required (WGS84)
HDG data	Required	Optional
ROT data	TI-ROT If connectable, enter the data.	Not required.

Chapter 2. Initial Setup

Introduction

This chapter describes the details of various menus including “Initial Setup”, “Own Vessel Data”, and “Message”.

MMSI and a ship name specified at installation, as well as the settings for external connections are set from the Initial Setup menu. To recall [Ship Static Edit] from this menu, Login Name and Password are required. For details, see Furuno Information: FQ4-2009-014.

Login Name and Password for this menu differ from those to enter the For Service menu.

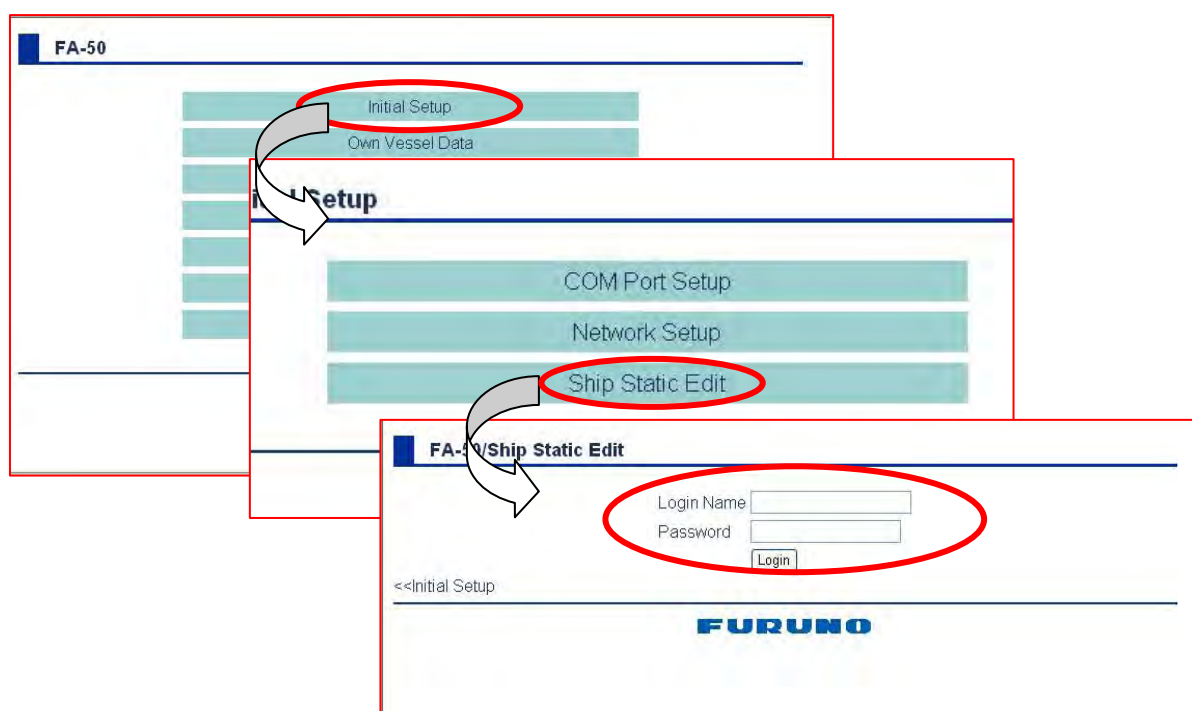

COM Port Setup

The COM port setup defines connections with the external display devices such as Radar and the external GPS according to RS-422 specifications. You can select from Data Type and TX, RX Speed.

Network Setup

The Network Setup defines IP address and subnet mask required to establish LAN connections with the external AIS display devices, such as NAVNET and PC-MKD, according to Ethernet 10/100BASE-T standard.

Ship Static Edit

With this menu, static data including MMSI, Ship Name, Call-sign, INT/EXT GPS Antenna Position, and Ships Type can be defined. The data specified in this menu can be broadcasted as MSG. 24A, B every 6 minutes.

2.1 COM Port Setup

From this menu, settings of the COM port can be made. On the COM port, a sensor signal of Position, SOG, COG, or Heading can be connected. These external sensors are not mandatory. The position data and SOG/COG data are normally retrieved from the built-in GPS. The COM port can be also connected with an external display device, for example, Radar displaying AIS targets.

Depending on the connection type, the setting of the jumper: J14 on the MAIN&TX board is required in addition to the settings of “COM Port Setup”.

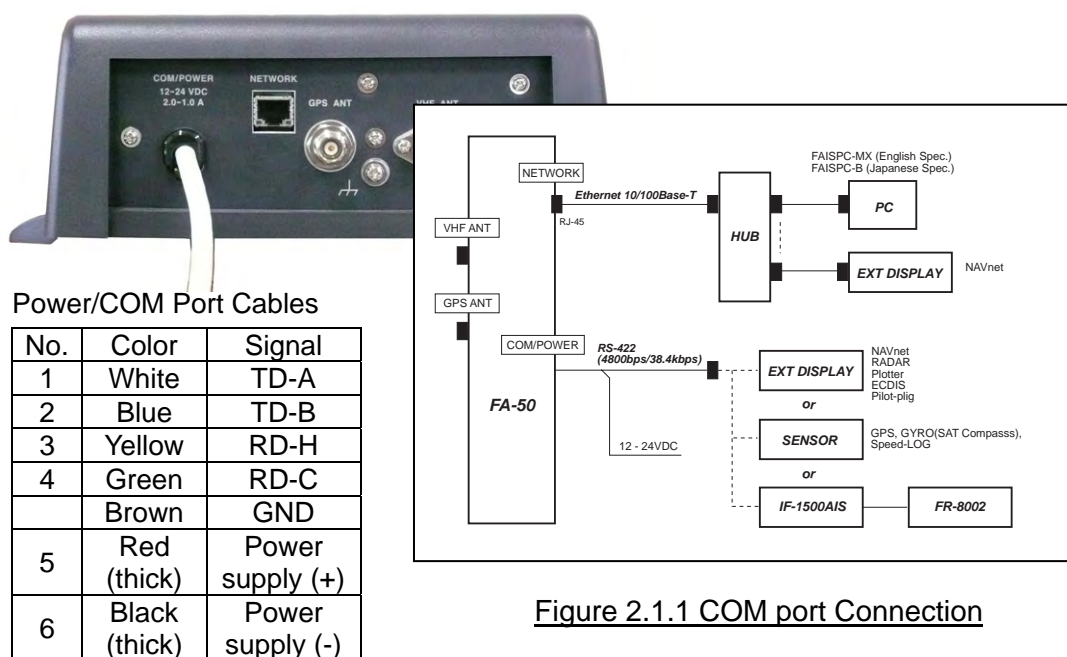

Figure 2.1.1 COM port Connection

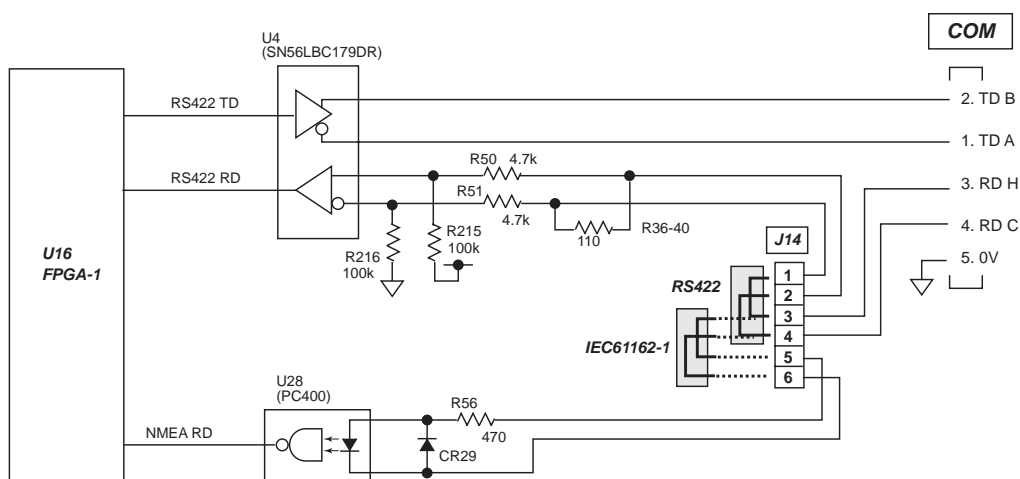

Figure 2.1.2 COM port Input/output Circuit

1. J14: Jumper Setup

Settings on the J14 jumper can define Rx data input specifications of the COM port. The Tx data output specifications are based on RS-422. The same sentences can be received regardless of the settings on J14.

Table 2.1.1 Examples of J14 Settings

Input selection	J14 Jumper block	Remarks
NMEA (IEC61162)	3/4/5/6 (Example of Use-1)	Transmission: RS-422, Reception: NMEA (IEC61162) For example, Tx data can be connected to the external display device of Radar set to display AIS information. Rx data can be connected to an external sensor, such as GPS. Therefore, 2 lines of connections: sensor data and AIS display data are supported. Note: Set a value to Rx Speed in COM Port Setup. Tx Speed is fixed at 38.4 kbps.
RS-422	1/2/3/4 (Example of Use-2)	Transmission/reception: RS-422 For example, pilot plug or Radar set for tow-way communication can be connected. Note: Set a value to Rx Speed in COM Port Setup. Tx Speed is fixed at 38.4 kbps.

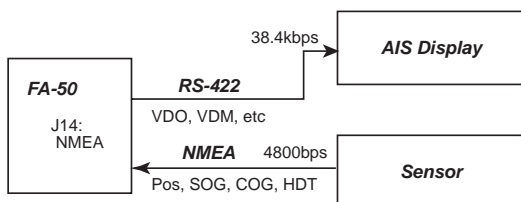

Example of Use-1

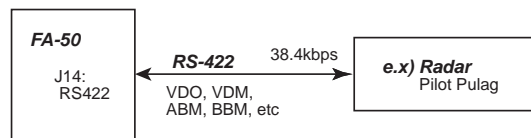

Example of Use-2

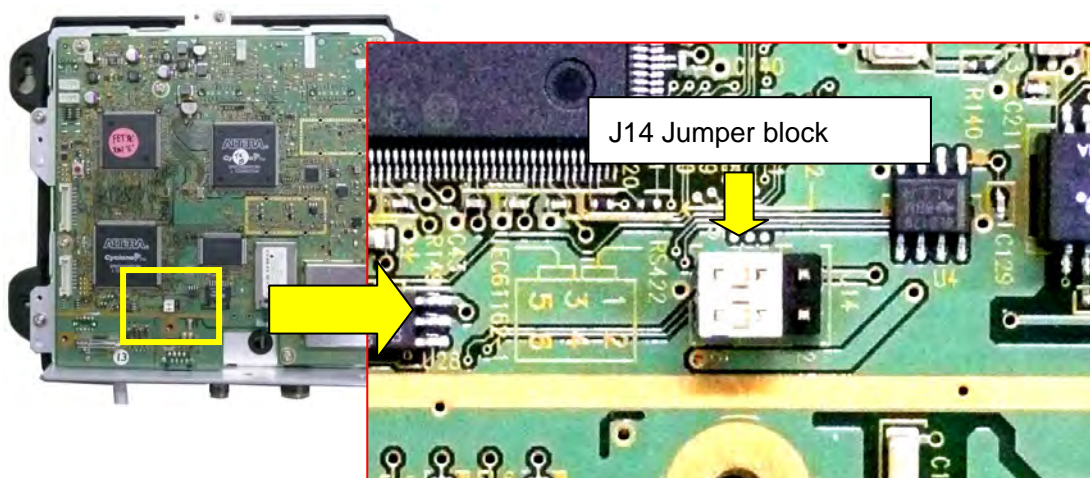

Figure 2.1.3 Location of J14

2. COM Port Setup

Data reception is allowed regardless of the setting of Data Type. The Rx data line specifications can be defined by setting on the J14 jumper.

The factory default settings as shown below can be applied regardless of the connection type.

- Data Type: IEC61162
- Rx Speed: Auto

The screenshot shows the 'FA-50/COM Port Setup' screen. It has three main sections: 'Data Type' with a dropdown menu set to 'IEC61162' and '(default=IEC61162)' to its right; 'TX Speed' with a text field containing '38400 bps'; and 'RX Speed' with two radio buttons, 'Auto' (selected) and 'Manual', and a dropdown menu set to '4800 bps' with '(default=Auto)' to its right. Below these are 'OK' and 'Cancel' buttons. At the bottom left, there is a '<<Initial Setup' option. The 'FURUNO' logo is centered at the bottom.

Table 2.1.2 Settings in COM Port Setup

Setting Item	Parameter	Description	
Data Type	IEC61162	It includes input/output NMEA sentences described in Appendix 4.	
	IEC61162+ P Sentence	In addition to the above sentences, PFEC sentence for communication with PC-MKD (FAISPC) are included. Note: Unlike FA-150, FA-50 does not incorporate a serially-connected PC-MKD so that this setting is not used.	
	Off	Transmission of Tx data is terminated. Exclusively for receive use.	
Tx Speed	38400 bps	Transmission speed of Tx data is fixed at 38400bps and unchangeable.	
Rx Speed	Auto	Independently of the settings on J14, Rx data retrieving is performed at a speed automatically matched with the Rx data rate. When a speed is determined, "Auto" is additionally indicated on the speed display.	
	Manual	4800bps	Independently of the settings on J14, Rx data retrieving is performed at a fixed speed of 4800bps.
		38400bps	Independently of the settings on J14, Rx data retrieving is performed at a fixed speed of 38400bps.

2.2 Network Setup

In this menu, a network can be set to connect with NAVNET 3 or others.
Setting a wrong address generates an error display above the [MAC Address] field.
Depending on the input item, the error display varies as follows:

- Input Error IP Address !
- Input Error Subnet Mask !
- Input Error Gateway Address !
- Input Error NavNet Port Number !

The screenshot shows the 'FA-50/Network Setup' screen. At the top, there is a title bar with 'FA-50/Network Setup' on the left and 'Error display area' in a box on the right. Below the title bar, there are several configuration fields:

MAC Address	00-D0-1D-02-FA-60	
IP Address	172.031.024.003	(default=172.031.024.003)
Subnet Mask	255.255.000.000	(default=255.255.000.000)
Gateway Address	000.000.000.000	(default=000.000.000.000)
NavNet Port Number	10000	(default=10000)
Host Name	AIS0	(default=AIS0)
AIS Data Output	Continuous:AIS	(default=Continuous:AIS)

At the bottom of the configuration area, there are 'OK' and 'Cancel' buttons. Below the configuration area, there is a '<<Initial Setup' button. At the very bottom of the screen, the 'FURUNO' logo is displayed.

When completing the settings, click the [OK] button. Then, on the screen as shown below, click [YES].

The FA-50 automatically reboots and the settings become effective.

The screenshot shows the 'FA-50/Network Setup' screen with a confirmation dialog. The dialog text reads:

You must restart your FA-50
before the new settings will take effect.
Do you want to restart your FA-50 now ?
(It will take about 1 minute to restart your FA-50)

At the bottom of the dialog, there are 'Yes' and 'No' buttons. Below the dialog, there is a '<<Network Setup' button. At the very bottom of the screen, the 'FURUNO' logo is displayed.

Table 2.1.3 Settings in Network Setup

Setting Item	Factory default settings	Description
MAC Address	xx-xx xx-xx xx-xx	Set at the factory. An address of the LAN controller.
IP Address	172.031.024.003	IP address of FA-50.
Subnet Mask	255.255.000.000	Specified with a subnet mask address of the network.
Gateway Address	000.000.000.000	Specified with a gateway address of the network. Normally, it is an IP address of the Router.
NavNet Port Number (Refer to 2-7)	10000	Used to process the PFEC sentences for connecting with PC-MKD. The actual port number is "1033" obtained by adding "33" to this number. Other port numbers are not acceptable.
Host Name	AIS0 (AIS0 ~ AIS9)	A host name used by NavNet is selected from "AIS0-AIS9". When multiple FA-50 are connected in the NAVNET3 network, the same host name should not be used for the different machines.
AIS Data Output	Auto	By request from a connection device which transmits data, such as NAVNET3, data output is performed.
	Continuous: AIS	Without identifying a destination, the output of AIS data: VDO, VDM etc. is continuously produced. (Refer to "1. List of Output Sentences" in AP4-6.)
	Continuous: GPS	Without identifying a destination, the output of GPS data is continuously produced. (GPS data includes position data: GGA, COG/SOG: VTG)
	Continuous: ZDA	Without identifying a destination, the output of time data is continuously produced. (Time data is ZDA.)
	Continuous: AIS/GPS	Without identifying a destination, the output of AIS: VDM/VDO and GPS data is continuously produced.
	Continuous: AIS/ZDA	Without identifying a destination, the output of AIS: VDO/VDM and time data is continuously produced.
	Continuous: GPS/ZDA	Without identifying a destination, the output of GPS and time data is continuously produced.
Continuous: AIS/GPS/ZDA	Without identifying a destination, the output of AIS: VDO/VDM, GPS, and time data is continuously produced.	

Note:

When AIS Data Output is specified with Continuous: GPS, GPS/ZDA, or ZDA, the output of AIS-related data is not produced and no AIS target is displayed on NAVNET 3 or Radar.

Even when NAVNET 3 is connected and the setting which produces no AIS data output, such as Continuous: GPS, is selected, the AIS data output can be produced by operating from NAVNET 3.

Reference

List of Port Numbers used by FA-50

LAN port number		Remarks
NAVNET Common	10010	For control purpose: port for communication with NAVNET
NAVNET Common	10011	Port for program update
NAVNET Private	10021	Shared with NMEA183 (AIS-related NMEA data: MAX SEA connection) VDO, VDM, HDT, ALM, TXT, etc.
NAVNET Private	10033 (10000)	Port for PC-MKD (Japanese Spc. FAISPC_B) connection PFEC, VDO, VDM, etc.

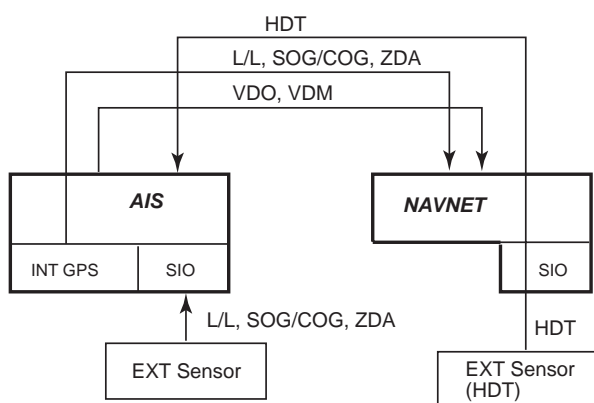

NAVNET Connection Example-1
(when sharing the built-in GPS)

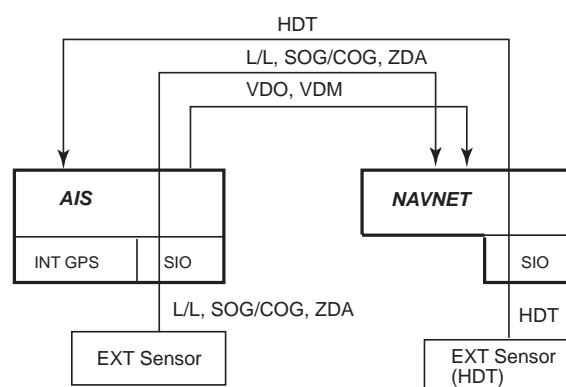

NAVNET Connection Example-2
(when sharing the external sensor)

Example of NAVNET settings

When sharing Heading Data with FA-50,

- Select [Installation Wizard] and set [DHCP Server] to “ON”.
- Open the [Own] tag and select the [NMAE Port1: Heading] connection port and set [Input Source type] to “Heading” to be able to share the Heading data.

When connecting with FA-50,

- Select [Installation Wizard] and set [DHCP Server] to “ON”.
- Open the [Global] tag and
 - select [Data Source] and set AIS: “FA-50” to retrieve the AIS data.
 - Setting of Heading: “Port1-Source” allows sharing of the Heading data.
 - Setting of Position SOG/COG: “FA-50” allows the FA-50 to retrieve data from NAVNET.

2.3 Ship Static Setup

To recall the [Ship Static Setup] menu, Login Name and Password are required. The own vessel static data specified in this menu is transmitted every 6 minutes. The data is divided into 2 parts: A and B and, over the same channel, part A is firstly transmitted and then part B within 1 minute. For details, refer to page AP3-8.

- Part A: MMSI, Ship Name etc.
- Part B: MMSI, Ship Type, Cargo Type, Vendor ID, Call Sign, Ship Size, Dimension of ship/reference for position, etc.

Setting a wrong value generates an error display above the [MMSI] field.

Error displays are the following:

- Input Error MMSI !
- Input Error Ship Name !
- Input Error Call Sign
- Input Error Antenna Position Internal A, B, C, D !
- Input Error Antenna Position External A, B, C, D !
- Input Error Ship Type !

The screenshot shows the 'FA-50/Ship Static Edit' screen. At the top left, the title 'FA-50/Ship Static Edit' is displayed. To its right is a box labeled 'Error display area'. Below this, the form contains the following fields:

- MMSI: 123456789
- Ship Name: FURUNO MARU
- Call Sign: JAAX
- Internal Antenna Position: A 40 m B 10 m C 3 m D 6 m
- External Antenna Position: A 40 m B 10 m C 6 m D 3 m
- Ship Type: 3 Vessel (dropdown menu)

At the bottom of the form are 'OK' and 'Cancel' buttons. Below the form, there is a '<<Initial Setup' button and the 'FURUNO' logo.

When completing the settings, click the [OK] button. The display returns to the Initial Setup screen.

Table 2.3.1 Settings in Network Setup

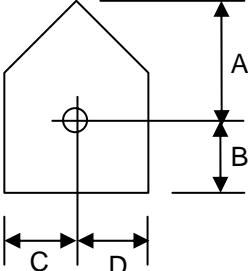
Setting Item	Factory default settings	Description
MMSI	000000000	<p>The allowable range of registration number is between 000000000 and 999999999 inclusive. An unregistered MMSI is expressed as "000000000". In this case, the TX lamp lights up in orange.</p> <p>When unregistered, transmission cannot initiate but reception is allowed. The received AIS message: VDM data can be outputted.</p> <p>Note: The initial setting value of MMSI of the class B unit must be 000000000.</p>
Ship Name	@ -- @ (hidden)	The allowable number of characters for registration is equal to or less than 20.
Call Sing	@ -- @ (hidden)	The allowable number of characters for registration is equal to or less than 7.
Internal Antenna Position	A=0, B=0, C=0, D=0	<p>The registration range of A/B is 0 to 511m, and C/D 0 to 63m.</p> <ul style="list-style-type: none"> - "Internal Antenna": Installed position of the antenna to be connected with FA-50. - "External Antenna": Installed position of the GPS antenna of the device which position data is to be entered to FA-50. 
External Antenna Position		
Ship Type	3 Vessel	<ol style="list-style-type: none"> 1. reserved for future use 2. WIG (Wing-In-Ground Effect Craft) 3. Vessel (fishing boats, towing boats, sailing boats, pleasure boats etc.) 4. HSC (high speed craft) 5. Special crafts 6. Passenger ships 7. Cargo ships 8. Tanker(s) <small>see next page)</small> 9. Other types of ship 10 – 19. Reserved for regional use 20 – 25. Reserved for future use <p>Note: The initial setting value of Ship Type of the Class B unit must be 37: pleasure boat.</p>

Note: Tanker Mode

Selecting Tanker as Ship Type recall the Tanker Mode, where a user can decrease the Tx output power to 1 W.

In the Tanker Mode, an item of “Tx Power” is added in the top page of the Web browser screen and clicking it allows users to manually select 1 W or Normal (2 W) of the Tx output power.

If you have been specify “Tx Power” by a Manual method from the Channel menu, that setting overrides the value selected here as described above.

Note:

Unlike FA-150, in the Tanker Mode of FA-50, the Tx output power does not automatically switch corresponding to the Ship Speed or Ship Status.

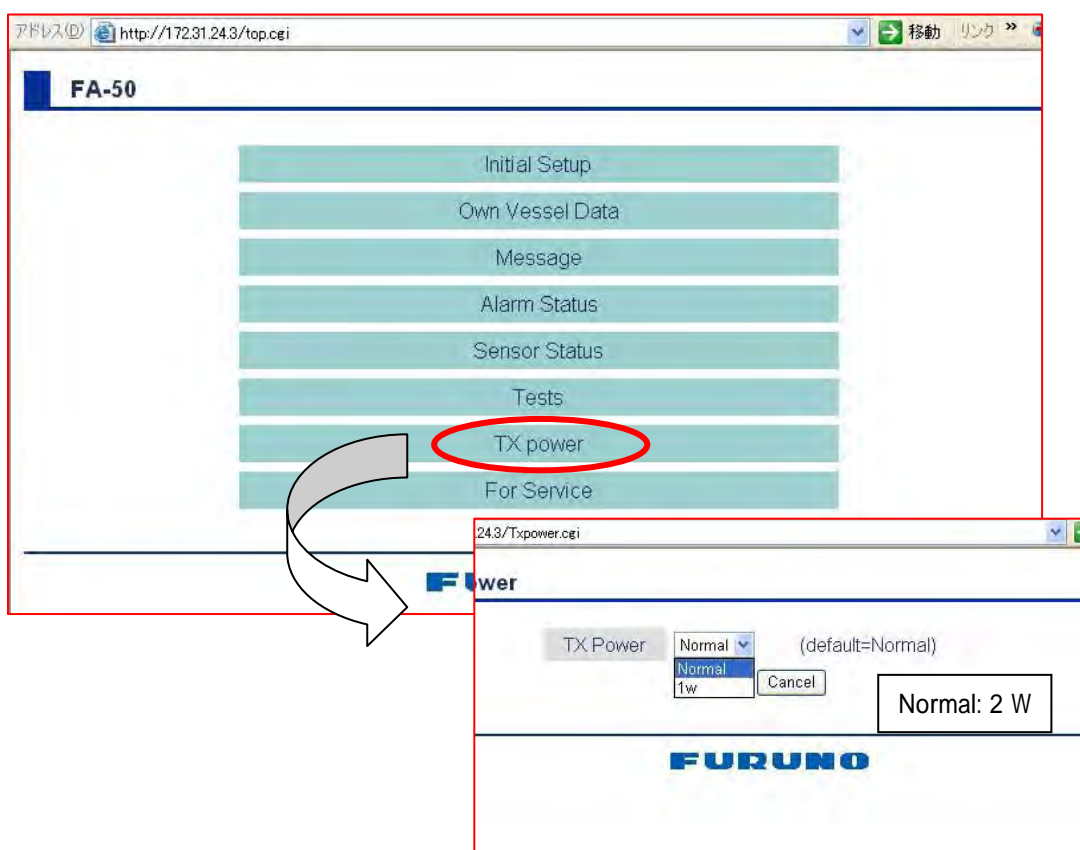

2.4 Own Vessel Data

The [Own Static] screen displays the data registered in the “Ship Static Edit” screen from the “Initial Setup” menu, while the [View Channel] displays the active channels. From this menu, select [Cargo Type Edit] to make a setting. A user can make a setting according to the “Cargo type”.

2.4.1 Own Static

Own Static

In this screen, the data registered in the “Ship Static Edit” screen from the “Initial Setup” menu is displayed.

FA-50/Own Vessel Data

Own Static		View Channel	
MMSI	432456789	RX1	CH.2087(International)
Ship Name	FURUNO	RX2	CH.2088(International)
Call Sign	JAAA	Power	2W
Internal Antenna Position	A 20 m B 5 m C 2 m D 3 m	<input type="button" value="Region List"/>	
External Antenna Position	A 0 m B 0 m C 0 m D 0 m	<input type="button" value="Group Assignment"/>	
Ship Type	3 Vessel		
Cargo Type	0 Fishing		

<<Top Menu

FURUNO

Cargo Type Edit

According to the Ship Type, follow the instructions described below. A user can make a selection according to the “Cargo type”.

When the Ship Type is [7 Cargo Ships], [6 Passenger ships], [8 Tanker(s)], [2 WIG], [4 HSC], or [9 Other types of ship], select a “Cage Type” from the list as shown below:

0 All ships of this type

0 All ships of this type

1 Carrying DG, HS, or MP, IMO hazard or pollutant category X

2 Carrying DG, HS, or MP, IMO hazard or pollutant category Y

3 Carrying DG, HS, or MP, IMO hazard or pollutant category Z

4 Carrying DG, HS, or MP, IMO hazard or pollutant category OS

5 Reserved for future use

6 Reserved for future use

7 Reserved for future use

8 Reserved for future use

9 No additional information

When the Ship Type is [**3 Vessel**], select a “Cage Type” from the list as shown below:

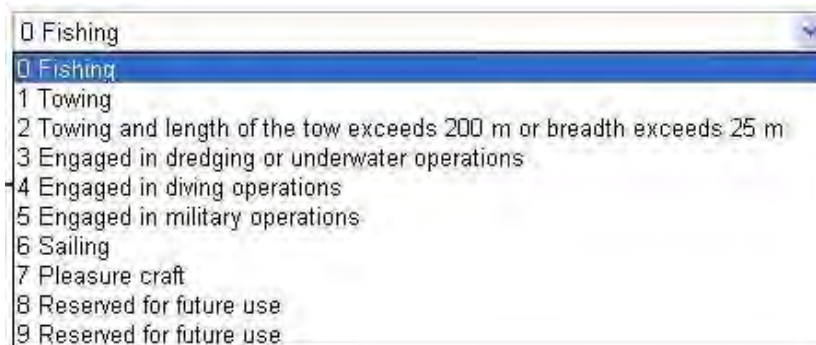

When the Ship Type is [**5 Special craft**], select a “Cage Type” from the list as shown below:

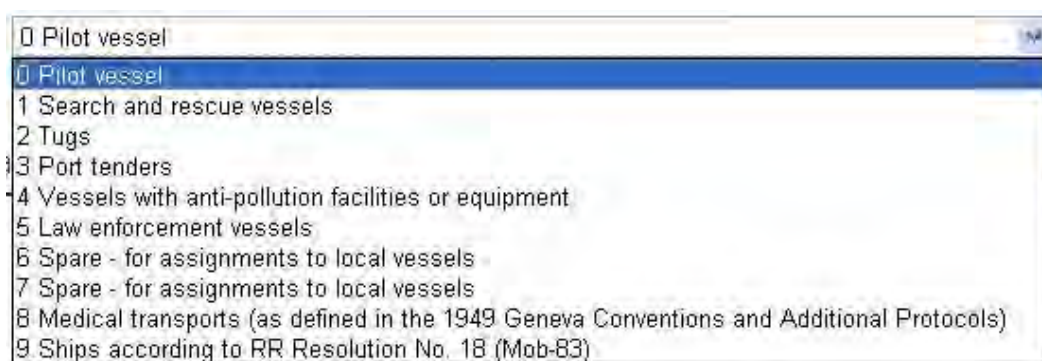

2.4.2 View Channel

View Channel

RX1 :

If no regional operation area setting is specified, “CH2087 (International)” is displayed.

If regional operation area setting is specified, “CHxxx (Local)” of the active channel is displayed.

RX2 :

If no regional operation area setting is specified, “CH2088 (International)” is displayed.

If regional operation area setting is specified, “CHxxx (Local)” of the active channel is displayed.

Power :

The value of the Tx output power currently effective is displayed.

If the “Power” field indicates “x W (Manual)”, “Manual” has been specified by selecting For Service -> Channel-> Channel Selection.

Region List

It displays nine different areas in the list. An area is determined by the coordinates of the upper right corner and the lower left corner of the rectangular region. The coordinates indicated with High Sea stand for international waters where Message 22 has not been yet received from the base station.

When Message 22 is received, following the instructions described in the message, the area is determined by the latitude and longitude and, if entered into that area, "Local Frequency Operation" effective in the instructed channel becomes active.

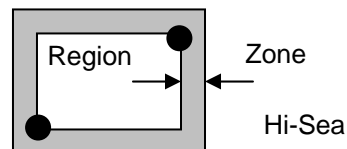

Click [Detail] to see the details.

No	Lat NE	Lon NE	Lat SW	Lon SW	Ch.A	Ch.B	TX	Rx	Detail
1	High Sea	High Sea	High Sea	High Sea	2087	2088	AB	AB	Detail
2									Detail
3									
4									
5									
6									
7									
8									
9									

No	Time	Lat NE	Lon NE	Lat SW	Lon SW	Ch.A/Band	Ch.B/Band	TRX Mode	Zone / Power	Enter
1	--/-- --:--	High Sea	High Sea	High Sea	High Sea	2087 / Default	2088 / Default	TxA / TxB , RxA / RxB	5 nm/ 12.5W	High Sea

No	Lat NE	Lon NE	Lat SW	Lon SW	Ch.A	Ch.B	TX	Rx	Detail
1	35-00.0',N	136-00.0',E	34-00.0',N	135-00.0',E	2088	2087	AB	AB	Detail
2	High Sea	High Sea	High Sea	High Sea	2087	2088	AB	AB	Detail
3									
4									
5									
6									
7									
8									
9									

No	Time	Lat NE	Lon NE	Lat SW	Lon SW	Ch.A/Band	Ch.B/Band	TRX Mode	Zone / Power	Enter
1	15/NOV/2007 04:32	35-00.0',N	136-00.0',E	34-00.0',N	135-00.0',E	2088 / Default	2087 / Default	TxA / TxB , RxA / RxB	6 nm/ 2W	MSG22

Group Assignment

For details, refer to page AP3-11.

While regularly broadcasting Message 23: Group Assignment from the base station, the list as shown below appears when this message is received.

In the Assigned Mode, when the vessel enters into the assigned area, the own vessel data is sent at intervals and in mode directed automatically.

In the Quiet Mode, when the vessel enters into the assigned area, the own vessel data is not sent for a time period between 1 and 15 minutes inclusive which is directed automatically.

The Quiet area has higher priority than the Assigned area in operation.

FA-50/Group Assignment			
Assigned Mode		Quiet Mode	
Last Time	7 min	Last Time	3 min
Lat NE	35-00.0000',N	Lat NE	35-00.0000',N
Lon NE	136-00.0000',E	Lon NE	136-00.0000',E
Lat SW	34-00.0000',N	Lat SW	34-00.0000',N
Lon SW	135-00.0000',E	Lon SW	135-00.0000',E
Report Interval	5 sec		
TRX Mode	TxA / TxB , RxA / RxB		
Own Vessel Data			

- When MSG. 22 is received
According to the directions in the message, the “Regional operation area” is performed.
- When only MSG. 23 is received
According to the directions in the message, the “Regional operation area” in either Assigned or Quiet Mode is performed.
In MSG. 23, however, neither channel nor Tx output power is specified so that the transmission is performed by 2 W over the international channels (CH2087, 2088).
- When MSG. 22 and 23 are received,
The “Regional operation area” is performed in order of priority according to MSG. 22(Addressed) > MSG. 23 > MSG. 22(Broadcast) to all vessels.

2.5 Message

From this menu, you can send a message using Message 14 and check both TX Log and RX Log.

These messages are saved in the FA-50.



Send Message

The Send Message function sends a message to all vessels by the CSTDMA method using Message 14: Safety Related Broadcast Message. This message is a standardized message previously created by executing For Service -> Edit Message.

One message per minute is allowed to be sent. If trying to send another message within one minute, a message appears saying "Still sending the previous message. Try again later."

If failed, a message appears saying "Failed to send the message (TX: Once a minute)". The messages that have been sent are recorded in the TX Log.



Tx Log

The Tx Log screen displays a maximum number of 20 Logs of the messages sent by Send Message. When the number of messages stored reaches to the maximum number, the messages are automatically deleted in lastest order.

- Date/Time :Date and time of ZDA data
- CH :Displays the channel used for transmission.
Normally, the transmission channel is switched between A and B alternately.
The channel is determined depending on the setting by For Service -> Channel.
- Message :Displays the contents of the sent messages (16 characters at maximum).
- Flag :Displays either one of “---, OK, NG”. “---“ stands for “in the process of determination”, while “OK” stands for “successfully transmitted” and “NG” “transmission failed”.

Tip:

If a message appears saying “Failed to send the message (TX: Once a minute)”, it means NG.

FA-50/TX Log						
No	Date	Time	CH	Message	Flag	
1	28/APR/2009	06:15	A	STARBOARD SIDE	---	
2	28/APR/2009	06:00	B	ANCHOR	OK	
3	28/APR/2009	05:59	B	ANCHOR	NG	
4	28/APR/2009	05:59	B	ANCHOR	OK	
5	28/APR/2009	05:58	B	PORT SIDE	NG	
6	28/APR/2009	05:58	B	ANCHOR	NG	
7	28/APR/2009	05:57	B	ANCHOR	OK	
8	28/APR/2009	05:57	B	ANCHOR	NG	
9	28/APR/2009	05:56	A	STARBOARD SIDE	OK	
10	28/APR/2009	05:56	A	MAN OVER BOARD	NG	

<<Message

FURUNO

Rx Log

Displays a maximum number of 20 messages that have been received. When the number of messages stored reaches to the maximum number, the messages are automatically deleted in chronological order.

The following three types of messages can be received:

- Message 8 : Broadcast Normal (Binary Broadcast Message)
- Message 12 : Addressed Safety (Safety Related Addressed Message)
- Message 14 : Broadcast Safety (Safety Related Broadcast Message)

The screenshot displays the 'FA-50/RX Log' interface. At the top, it shows 'page(1/1)'. Below this is a table with columns: No, Date, Time, MSG, CH, MMSI, Text, and Flag. The first message (No. 1) is highlighted, and its 'Detail' button is circled in red. An arrow points from this button to a larger 'Detail screen' window. This window shows the following information for message No. 1:

No	1
Date	28/APR/2009
Time	07:25
MSG	12
CH	A
MMSI	111118888
TEXT	ADD CAST TEST*ADGJMPTW123456789123456789

At the bottom of the interface, there are navigation buttons: '<<RX Log', 'Message 8 = Broadcast Normal 12 = Addressed Safety 14 = Broadcast Safety', and '<<Message'. The 'FURUNO' logo is visible at the bottom center.

- Date/Time : Date and time of ZDA data
- MSG : Displays the type of the message received.
- CH : Displays the channel used for reception.
- MMSI : Displays MMSI of the transmitting station.
- Text : Displays the received messages (16 characters at maximum).
- Flag : “Not Read” means that the message has not been opened by clicking [Detail], while “Read” means that it has been already opened.

Chapter 3. Parts Location

3.1 FA-50

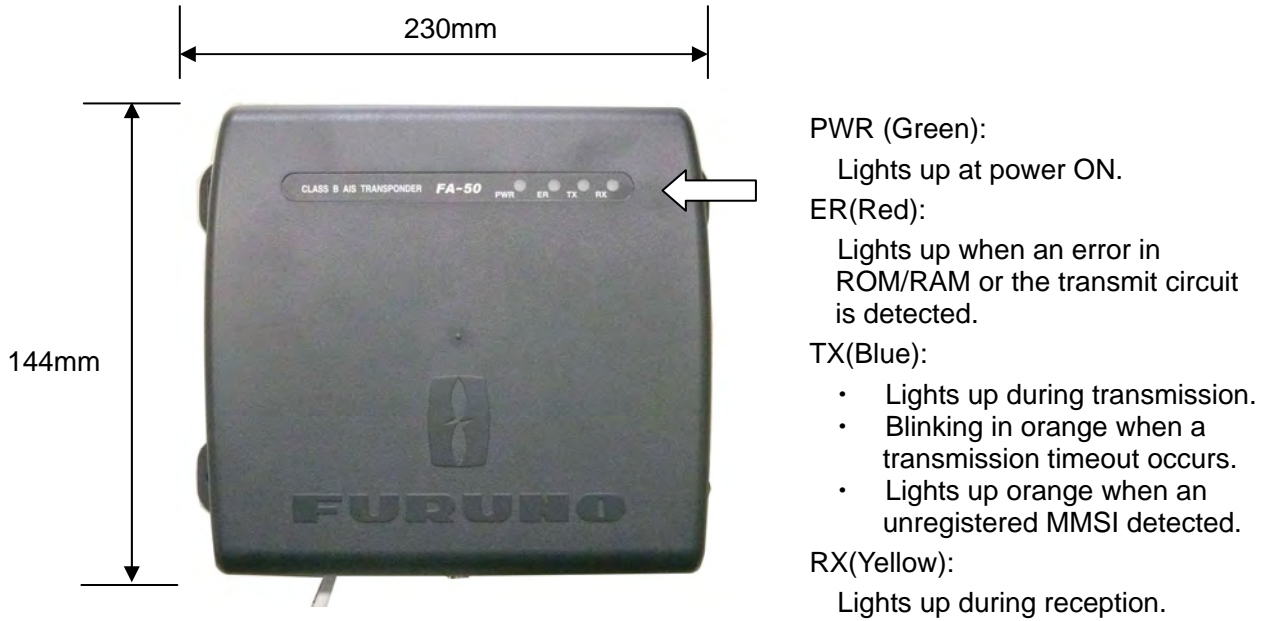

Figure 3.1.1 FA-50

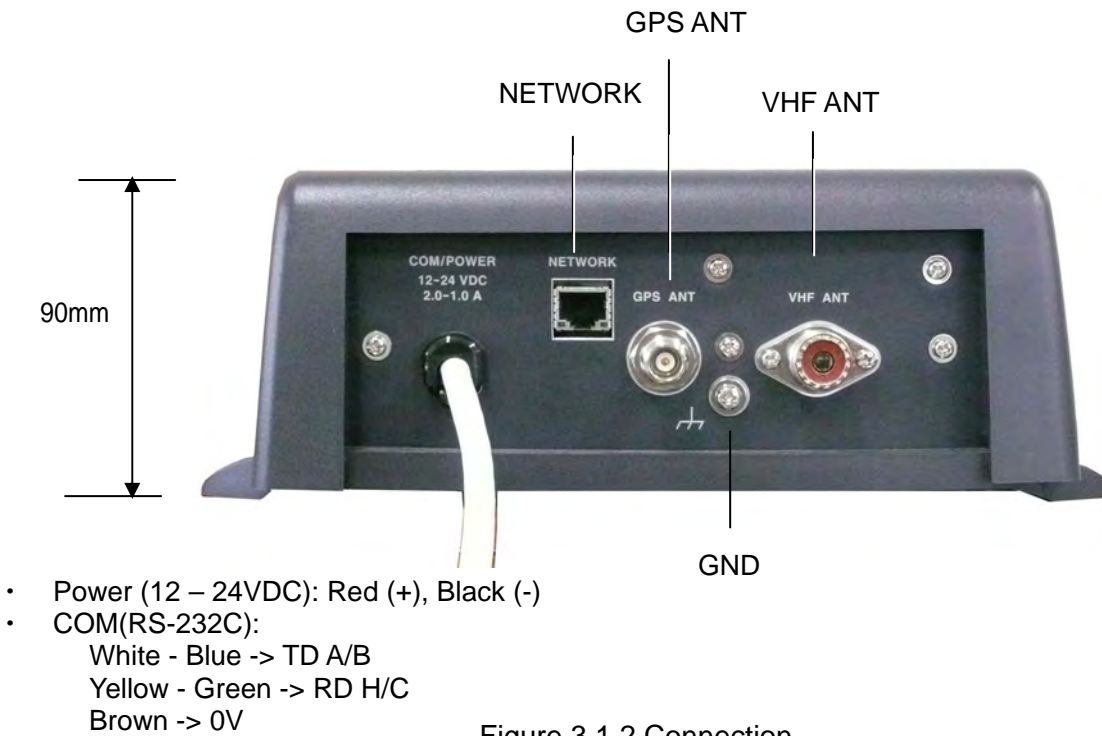

Figure 3.1.2 Connection



Figure 3.1.3 Cover removed

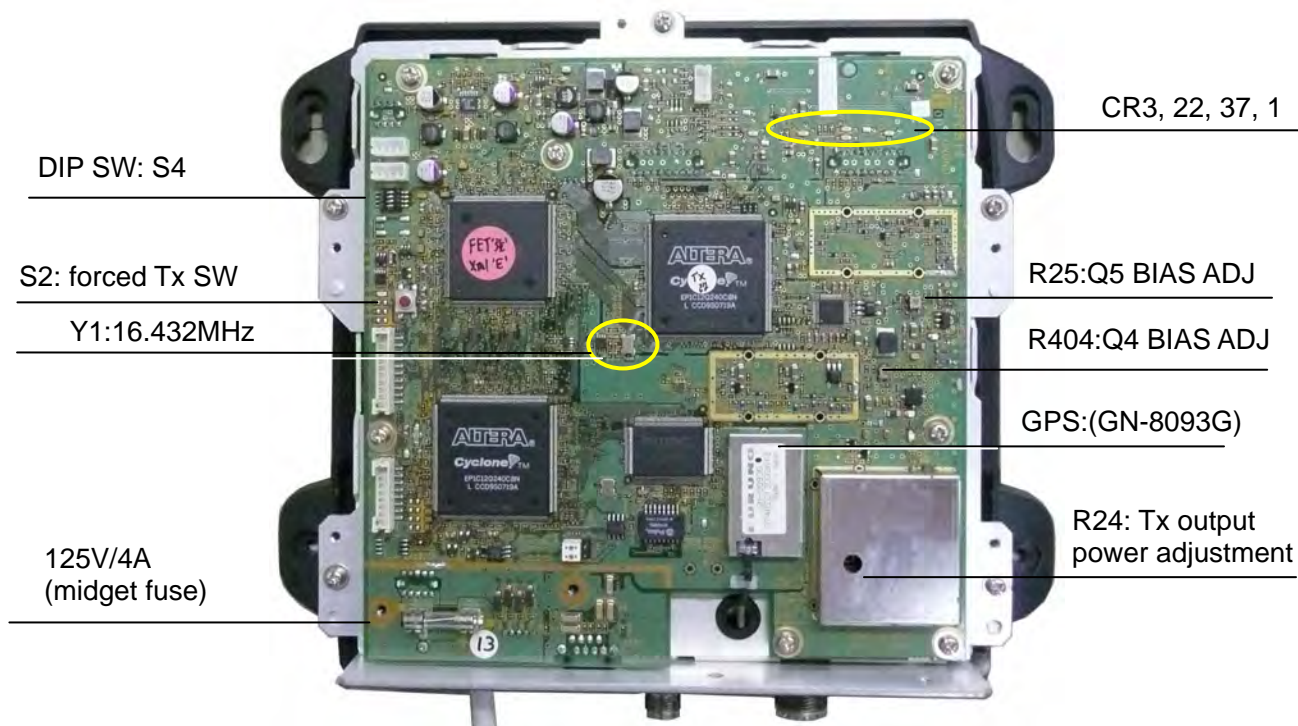

Figure 3.1.4 Shield cover removed

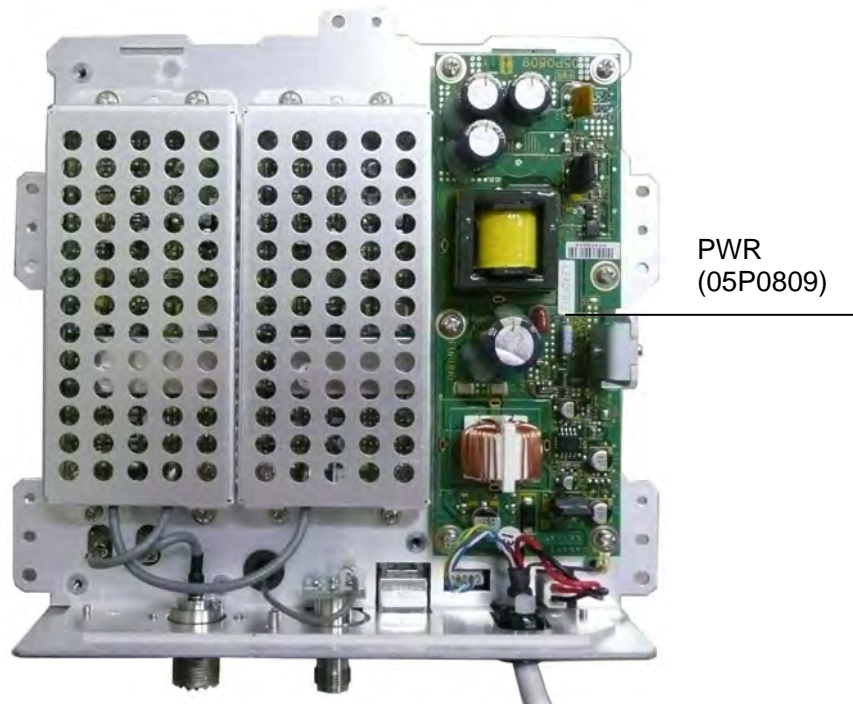

Figure 3.1.5 Back Side

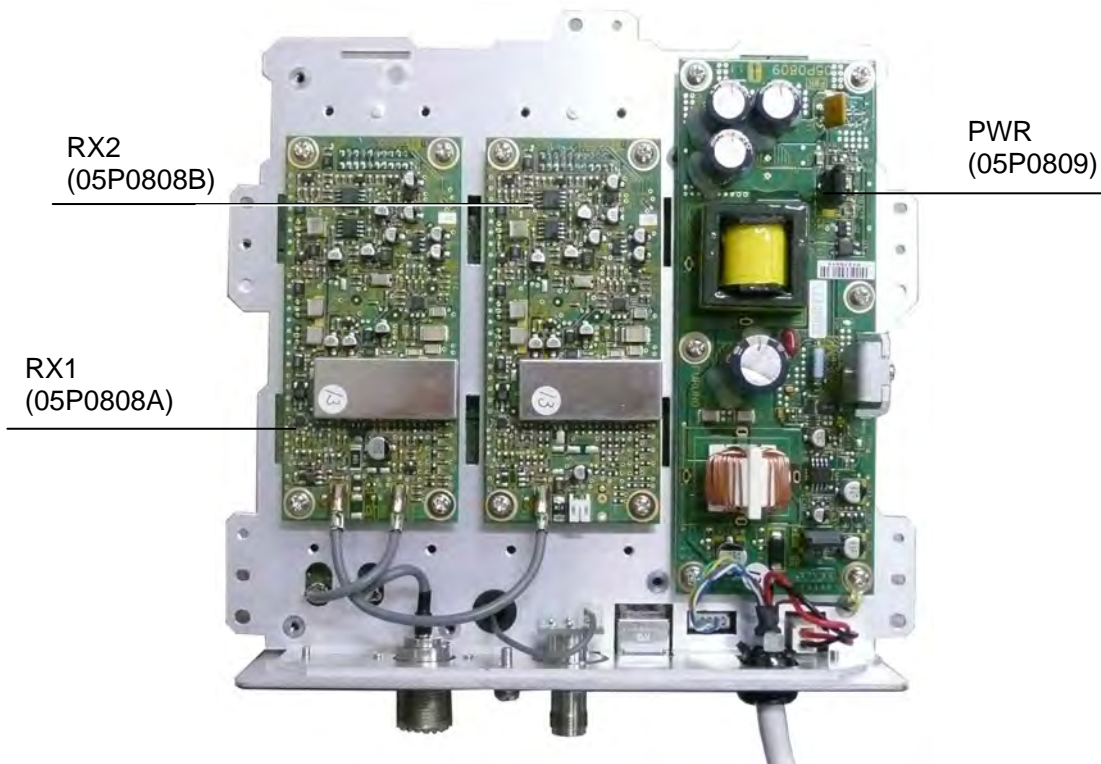

Figure 3.1.6 RX board shield cover removed

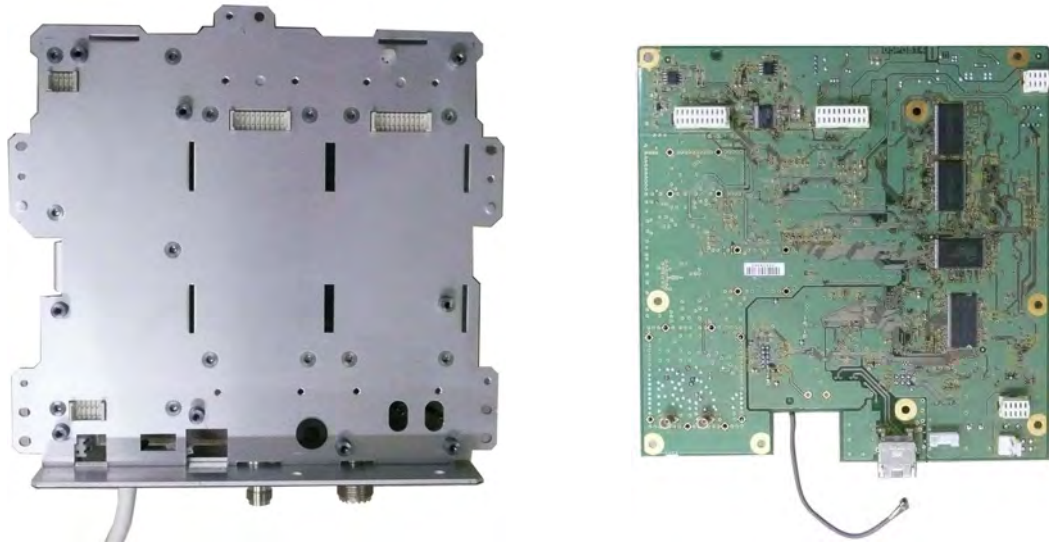

Figure 3.1.7 Casing and B side of the MAIN & TX board

GPS antenna relay board
(24P0043)



Figure 3.1.8 GPS Antenna Relay board

R2: 12 VDC AVR ADJ.
Switching frequency check
Between TP4 and 3: 170 kHz to 230 kHz



Figure 3.1.9 PWR Board (05P0809)

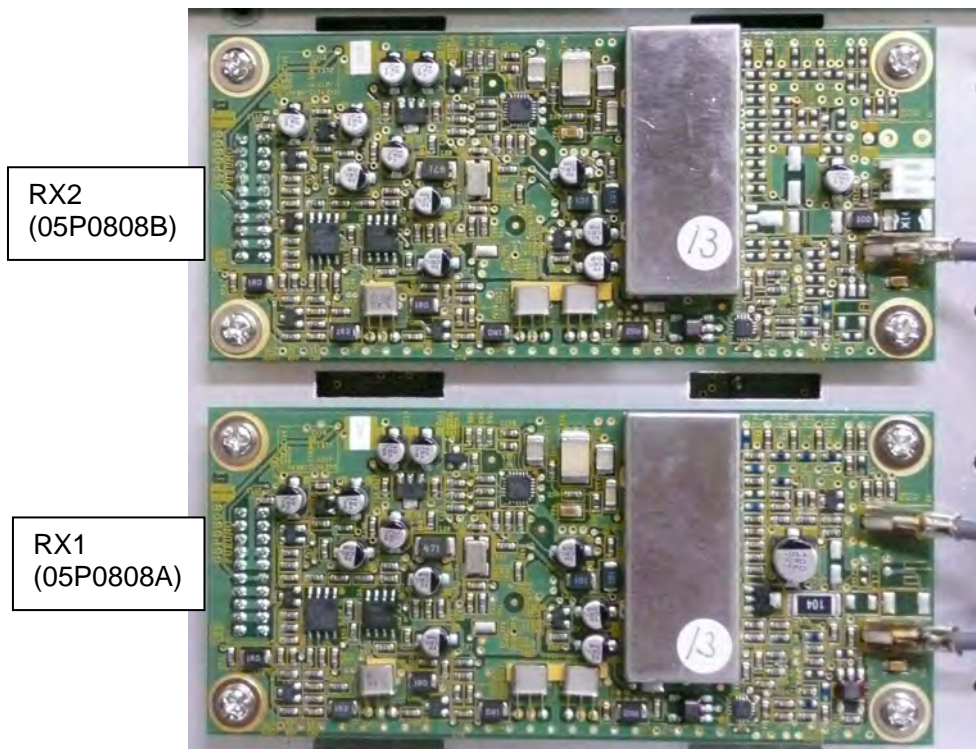

Figure 3.1.10 RX Boards (05P0808A, B)

3.2 GVA-100: Combined Antenna

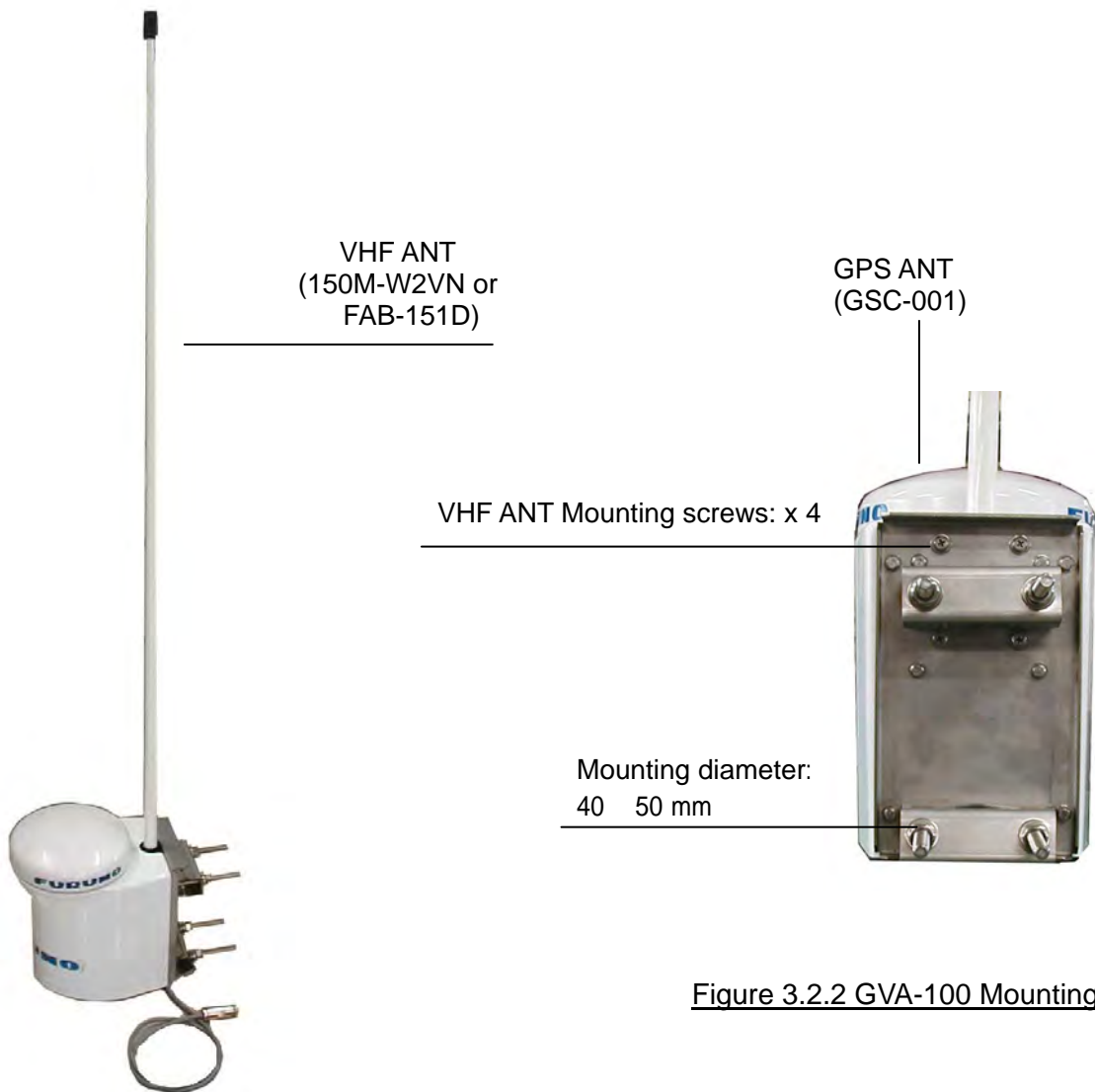

Figure 3.2.1 GVA-100

Figure 3.2.2 GVA-100 Mounting



Figure 3.2.3 GAV-100 with the cover removed

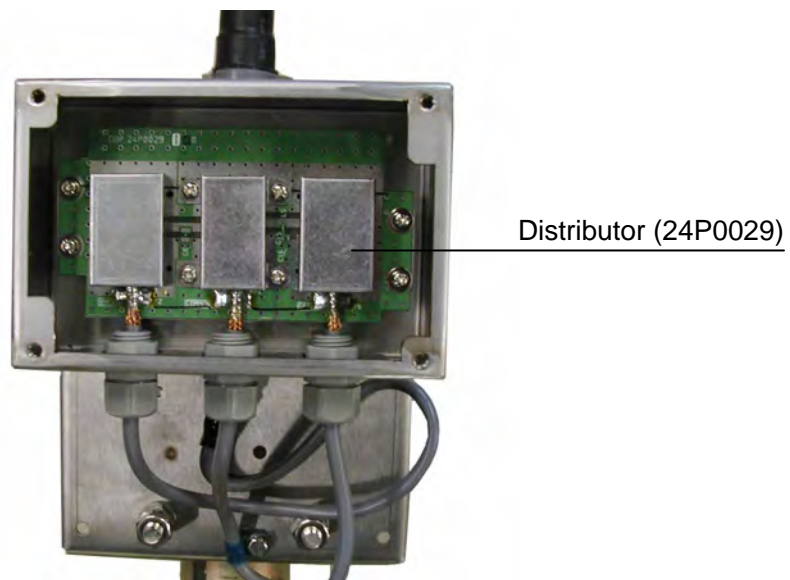

Figure 3.2.4 Distributor with the cover removed

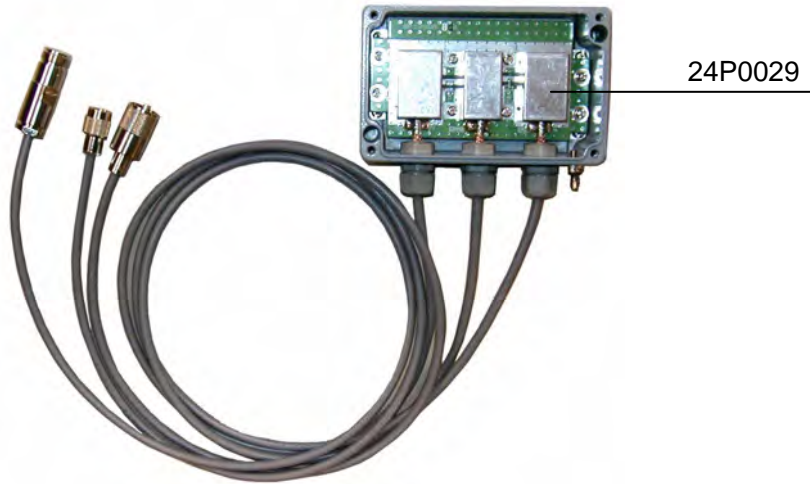

Figure 3.2.5 DB-1 (Distributor)

Chapter 4. Menu Tree

4.1 Web browser Screen

Start Internet Explorer and enter “http://172.31.24.3” in the URL field to open the Web browser screen of FA-50.

Password and Login Name are required when entering to the [Ship Static Edit] menu from [Initial Setup] and to the [For Service] menu.

For details of Password and Login Name, see Furuno Information: FQ4-2009-014.



Top page of the Web browser screen

Top Menu	Sub Menu-1	Sub Menu-2	Sub Menu-3	Sub Menu-4	Sub Menu-5	Note	
Initial Setup <i>Cont'd</i>	COM Port	Data Type	IEC61162				
			IEC61162 + P-sentence				
			Off				
			TX Speed	38400 bps			Fixed
				Auto			
			RX Speed	Manual	38400 bps 4800 bps		
		[OK] [Cancel]					
		MAC Address	ex) 00-D0-1D-02-FA-60			MAC address of LAN I/F on the MAIN board.	
	Network <i>Cont'd</i>	IP Address	172.031.024.003				
		Subnet Mask	255.255.000.000				
		Gateway Address	000.000.000.000				
		NavNet Port Number	10000				
		Host Name	AIS0 - AIS9				

Top Menu	Sub Menu-1	Sub Menu-2	Sub Menu-3	Sub Menu-4	Sub Menu-5	Note	
Initial Setup <i>Cont'd</i>	Network	AIS Data Output	Continuous: AIS				
			Continuous: GPS				
			Continuous: ZDA				
			Continuous: AIS/GPS				
			Continuous: AIS/ZDA				
			Continuous: GPS /ZDA				
			Continuous: AIS/ GPS / ZDA				
		Auto					
		MMSI		000000000			
		Ship Name					20 characters at maximum
	Call Sign					7 characters at maximum	
	Ship Static Login Name: [furunoservice] Password: [FA50]	Internal Antenna Position	A: 0 m, B: 0 m C: 0 m, D: 0 m				
External Antenna Position		A: 0 m, B: 0 m C: 0 m, D: 0 m					
	<i>Cont'd</i>		1 Reserved future use				
		Ship Type	2 WIG				
		<i>Cont'd</i>	3 Vessel				
			4 HSC				

Top Menu	Sub Menu-1	Sub Menu-2	Sub Menu-3	Sub Menu-4	Sub Menu-5	Note	
Initial Setup	Ship Static	Ship Type	5 Special craft				
			6 Passenger ships				
			7 Cargo ships				
			8 Tanker(s)				
			9 Other types of ship				
			10 – 19 Reserved for regional use				
			20 – 25 Reserved for future use				
			000000000				
			MMSI				
			Ship Name				
Own Vessel Data <i>Cont'd</i>	Own Static	Own Static	Call Sign			Displays the data registered in the [Ship Static] screen of [Initial Setup].	
			Internal Antenna Position	A: 0 m, B: 0 m C: 0 m, D: 0 m			
			External Antenna Position	A: 0 m, B: 0 m C: 0 m, D: 0 m			
			Ship Type	3 Vessel;			
			Cargo Type	7 <i>Pleasure craft</i>			
			[Cargo Type Edit]	Refer to page 4-17.			
					According to the Ship Type, a Cargo Type selected in the [Cargo Type Edit] screen is displayed.		

4.1 Web browser Screen

Top Menu	Sub Menu-1	Sub Menu-2	Sub Menu-3	Sub Menu-4	Sub Menu-5	Note	
Own Vessel Data <i>Cont'd</i>	View Channel <i>Cont'd</i>	RX1	ex: CH.2087(International)			The values specified by executing For Service -> Channel are displayed.	
		RX2	ex: CH.2088(International)				
		Power	ex: 2W				
				No.1 - 9			The regional operation area data contained in the received MSG. 22 and 23, which are broadcasted from VTS, is displayed. Note: In this example, the values when no regional operation area data has been received are described.
				Lat NE	High Sea		
				Lon NE	High Sea		
				Lat SW	High Sea		
				Lon SW	High Sea		
				Ch A	2087		
				Ch B	2088		
				TX	AB		
				RX	AB		
					No	1	
					Time	--/--/--- --:--	The details of selections made in Region List (1-9) are described. Note: In this example, the values when no regional operation area data has been received are described.
			Lat NE	High Sea			
			Lon NE	High Sea			
			Lat SW	High Sea			
			Lon SW	High Sea			
			Ch A/Band	2087/Default			
			Ch A/Band	2088/Default			

Top Menu	Sub Menu-1	Sub Menu-2	Sub Menu-3	Sub Menu-4	Sub Menu-5	Note
Own Vessel Data	View Channel	[Region List]	[Detail]	TRX Mode	TXA/TXB, TXA/RXB	The regional operation area data of MSG. 23 is displayed and, according to this data, FA-50 operates. This data is updated when latest data is received. (The regional operation area data of MSG. 23 from VTS is periodically broadcasted.) Note: The data shown on the left is for reference purposes. By setting the transmission prohibited area, these values are displayed based on the contents of MSG. 23. Operation is performed in the same manner as Assigned Mode.
				Zone/Power	5nm/12.5W	
		Enter	High Sea			
		Last Time	7 min			
		Lat NE	35.00.0000°N			
		Lon NE	13600.0000°E			
		Lat SW	34.00.0000°N			
		Lon SW	135.00.0000°E			
		Report Interval	5 sec			
		TRX Mode	TxA/TxB, RxA/RxB			
		Last Time	7 min			
		Lat NE	35.00.0000°N			
		Lon NE	13600.0000°E			
		Lat SW	34.00.0000°N			
Lon SW	135.00.0000°E					
			Assigned Mode			
			Quit Mode			

Top Menu	Sub Menu-1	Sub Menu-2	Sub Menu-3	Sub Menu-4	Sub Menu-5	Note	
Message Cont'd	Send Message	Select Message	1. ANCHOR			Addition and edit of Message can be performed by executing For Service -> Edit Message. 16 characters at maximum. Note: The messages shown on the left are the factory default settings. Only MSG TYP of MSG. 14 (Broadcast Safety), containing 16 characters maximum, is allowed to be sent.	
			2. AGROUND				
			3. MAN OVER BOARD				
			4. STARBOARD SIDE				
			5. PORT SIDE				
			6. MAYDAY				
			[Send]	Send Message "xxx" Are you sure? [Yes] [No]			
		No		1			
		Date		01/OCT/2008			In Data and Time, ZDA from the internal GPS are displayed.
		Time		15:00			Note: The data shown on the left is for reference purposes.
	CH		A				
	Message		ANCHOR				
	Flag		OK				
	TX Log						

4.1 Web browser Screen

Top Menu	Sub Menu-1	Sub Menu-2	Sub Menu-3	Sub Menu-4	Sub Menu-5	Note	
Message	RX Log	No	1			1) MSG 8, 12, and 14 can be received. 2) In Data and Time, ZDA from the internal GPS are displayed. 3) @ used in Text indicates a blank. 4) Not Read in Flag switches to Read when the MSG is read. (Click on [Detail]). Note: The data shown on the left is for reference purposes.	
		Date	01/OCT/2008				
		Time	15:00				
		MSG					
		CH	B (A)				
		MMSI	123456789				
		Text	@@ ----@@ (max.16)				
		Flag	Not Read (Read)				
			No	1			
			Date	01/OCT/2008			
	Time	15:00					
	MSG						
	CH	B					
	MMSI	123456789					
	TEXT	@@@@					
	Type	ex) TX				ALMs currently occur are displayed. The data shown on the left is for reference purposes. Note: TX, RX1, RX2; however, COG, EPFS, HDG, L/L, SOG can be set to be either displayed or not displayed by setting ON/OFF in the NMEA menu accessed from For Service.	
	UTC	15:00					
Alarm Status	Description	ex) Tx malfunction					

4.1 Web browser Screen

Top Menu	Sub Menu-1	Sub Menu-2	Sub Menu-3	Sub Menu-4	Sub Menu-5	Note
Sensor Status	ex) Internal DGPS in use Internal SOG, COG in use					The sensors currently used are displayed. For details, refer to page 8-23.
		Version	0550233-01.0x			
Tests	Transponder Test	CPU1 RAM	OK/NG			
		CPU2 RAM	OK/NG			
		ROM	OK/NG			
		RX1	OK/NG			PLL-Unlock check of RX1, 2.
		RX2	OK/NG			
		TX	OK/NG			
		Version	485026400x			
	ROM	OK/NG/Timeout Error				
	RAM	OK/NG/Timeout Error				
		GPS Test	Antenna	OK/NG/Timeout Error		

Silent Mode and Tanker Mode

Top Menu	Sub Menu-1	Sub Menu-2	Sub Menu-3	Note
Silent (<i>Silent Mode</i>)	Normal			When selecting For Service -> Other -> Silent and setting to ON, an item of [Silent] is added on the menu where a user can turn ON/OFF the Silent function.
	Silent			
Tx Power (<i>Tanker Mode</i>)	Normal			When selecting Initial Setup -> Ship Static Data -> Ship Type and setting "8: Tanker", an item of [Tx Power] is added on the menu where a user can switch the Tx output power between 1 W and Normal(2 W).
	1W			

Top Menu	Sub Menu-1	Sub Menu-2	Sub Menu-3	Sub Menu-4	Sub Menu-5	Note
For Service [Login name]: service [Password]: 652111 Cont'd	[Service Mode Logout]					
	Version	Version	0550233-01.0x			
		CPU 1	X1.1-5.B1.14 200806061154			
		CPU 2	Y2.27 3ch 200806061154			
		FPGA	01.100 20071123			
		Output VDM	Class A Class B All Message			
	NMEA Cont'd	Output VOD	Class A Class B A+B			
		Sentence without checksum	Use Don't use			

Top Menu	Sub Menu-1	Sub Menu-2	Sub Menu-3	Sub Menu-4	Sub Menu-5	Note
For Service [Login name]: service [Password]: 652111 Cont'd	NMEA	EPFS Alarm	Off			Various Alarm outputs can be set to either ON or OFF.
			On			
		L/L, SOG, COG Alarm	Off			
			On			
		HDG Alarm	Off			
			On			
	External GNNS	Use				
		Don't use				
	Demo		[OK] [Cancel]			
			Off			
TOKYO						
Cast Type		OSAKA				
		Broadcast			Settings used when the received AIS data is sent to the LAN-connected PC.	
		Unicast				
Post IP						

Top Menu	Sub Menu-1	Sub Menu-2	Sub Menu-3	Sub Menu-4	Sub Menu-5	Note
For Service [Login name]: service [Password]: 652111 Cont'd	Device Test Cont'd	TX Test Cont'd	[Select]	Carrier		
				1010101		
				110011		
				1111		
				PRS		
				Test2[33%] Training: 0101 Data: 01010101		
				Test2[50%]		
				Test2[100%]		
				Test2[33%] Training: 0101 Data: 00001111		
				Test3[50%]		
				Test3[100%]		
				Test4[33%] Training: 0101 Data:PRS		
				Test4[50%]		
				Test4[100%]		
				Test5 Training: 22Bit Message 18 A-Bch 1sec Rate (For Emission)		
Test2+1Bit(For Ramp)						

Top Menu	Sub Menu-1	Sub Menu-2	Sub Menu-3	Sub Menu-4	Sub Menu-5	Note
For Service [Login name]: <i>service</i> [Password]: 652111 Cont'd	TX Test	[Start]	Test Type	ex) Carrier	A modulation type selected in the Select menu is displayed.	
			Test Status	Stop (Start)	ON/OFF switches of transmission	
		Rx Test (Loop Back)	[Start]	[Start]	OK/NG	A leakage in Tx power is detected and tested.
				[Stop]	OK/NG	
		Receive Test	[Start]	Received stations	xx stations	Receipt status is displayed.
				RX1 Received packets (per 1min)	xxx packet	
	RX2 Received packets (per 1min)			xxx packets		
	RX1SS			x - x		
	RSSI Test	[Start]	RX2SS	x - x	Strength of received signals, 10 samples are displayed.	
			[Refresh]		RX1SS and RX2S are refreshed.	
	COM Port Test	[Start]	Com Port	OK/NG	Loop back test of the COM port	
	COM					
NavNet						
PCMKD						
GPS						
[Refresh]					Received data is displayed.	
					Received data is refreshed.	

Top Menu	Sub Menu-1	Sub Menu-2	Sub Menu-3	Sub Menu-4	Sub Menu-5	Note
For Service [Login name]: service [Password]: 652111 Cont'd	Memory Clear	Factory Rest without IP Address	[Yes] [No]			All data, except the settings in the Network setup menu of Initial Setup, is deleted.
		Factory Rest	[Yes] [No]			All data is deleted.
		RX1	2087			
		RX2	2088			
		TRX Mode	TXA+B/RXA+B			
			TXA/RXA+B			
			TXB/RXA+B			
			RXA+B			
			RXA			
			RXB			
		TX Power	2W			
			1W			
			0W			
		Channel Selection	Auto			
			Manual			
	DSC Time Sharing	On				
		Off				
	[OK] [Cancel]					Manual should be specified to do a manual operation. Whether the DSC (CH70) signal is received at RX1, RX2 is determined.

Top Menu	Sub Menu-1	Sub Menu-2	Sub Menu-3	Sub Menu-4	Sub Menu-5	Note	
For Service [Login name]: <i>service</i> [Password]: 652111 Cont'd	Internal GPS	LAT	34.44.4650'N			Internal GPS data is displayed. Note: The data shown on the left is for reference purposes.	
		LON	135.21.2912'E				
		SOG/COG	0.0kt/212.8 deg				
		MODE/STATUS	DGPS/D2D				
		RAIM/PA	ON/ON				
		UTC	02102008 092924				
	Edit Message	Message Select		1. ANCHOR			MSG to be edited is selected. Note: The MSG edited here can be sent by executing Message -> Send Message (MSG. 14).
				2. AGROUND			
				3. MAN OVER BOARD			
				4. STARBOARD SIDE			
			5. PORT SIDE				
			6. MAYDAY				
			7. -----				
			8. -----				
			9. -----				
			10. -----				
	Edit Message					The MSG selected above is edited (16 characters maximum).	
	[OK] [Cancel]						

Top Menu	Sub Menu-1	Sub Menu-2	Sub Menu-3	Sub Menu-4	Sub Menu-5	Note
For Service [Login name]: service [Password]: 652111	Other	Silent Mode	Off			Setting On : terminates transmission and allows reception only
			On			
		Channel Selection	International			Switching the channel.
		[OK] [Cancel]	USA			

R&D Menu

- Login Name: developer
- Password: 38603800

Table 4.1 Ship Type List

1. Reserved future use	2. WIG	3. Vessel	5. Special craft	4. HSC	6. Passenger ship	7. Cargo ships	8. Tanker(s)	9. Other types of ship	10 – 19 Reserved for regional use	20 – 25 Reserved for future use
0. All Ship of this type		0. Fishing	0. Pilot vessel	0. All Ship of this type						
1. Carrying DG, HS, or MP, IMO hazard or pollutant category X		1. Towing	1. Search and rescue vessels	1. Carrying DG, HS, or MP, IMO hazard or pollutant category X						
2. Carrying DG, HS, or MP, IMO hazard or pollutant category Y		2. Towing and length of the tow exceeds 200m or breadth exceeds 25m	2. Tugs	2. Carrying DG, HS, or MP, IMO hazard or pollutant category Y						
3. Carrying DG, HS, or MP, IMO hazard or pollutant category Z		3. Engaged in dredging or under water operations	3. Port tenders	3. Carrying DG, HS, or MP, IMO hazard or pollutant category Z						
4. Carrying DG, HS, or MP, IMO hazard or pollutant category OS		4. Engaged in diving operations	4. Vessels with anti-pollution facilities or equipment	4. Carrying DG, HS, or MP, IMO hazard or pollutant category OS					1 – 9 Reserved for regional use	1 – 9 Reserved for future use
5. Reserved for future use		5. Engaged in military operations	5. Low enforcement vessels	5. Reserved for future use						
6. Reserved for future use		6. Sailing	6. Spare- for assignments to local vessels	6. Reserved for future use						
7. Reserved for future use			7. Spare- for assignments to local vessels	7. Reserved for future use						
8. Reserved for future use			8. Medical transponders (as defined in the 1949 Geneva Conventions and Additional Protocols)	8. Reserved for future use						
9. Reserved for future use			9. Ship according to RR Resolutions No. 18(Mob-83)	9. No additional information						

Chapter 5. Block Diagrams

5.1 System Configuration

The FA-50 is Class B AIS device using CSTDMA (Carrier Sense TDMA) technology and consists of an AIS transponder unit and a VHF/GPS antenna unit, Two types of antennas are supplied and users can select either one according to their need.

- 1) Combined antenna consisting of VHF/GPS antennas: GVA-100
(Distributor: DB-1 equipped)
- 2) VHF/GPS separate type
 - VHF antenna: FAB-151D or 150M-W2VN
 - GPS antenna: GPA-017S or GPA-017

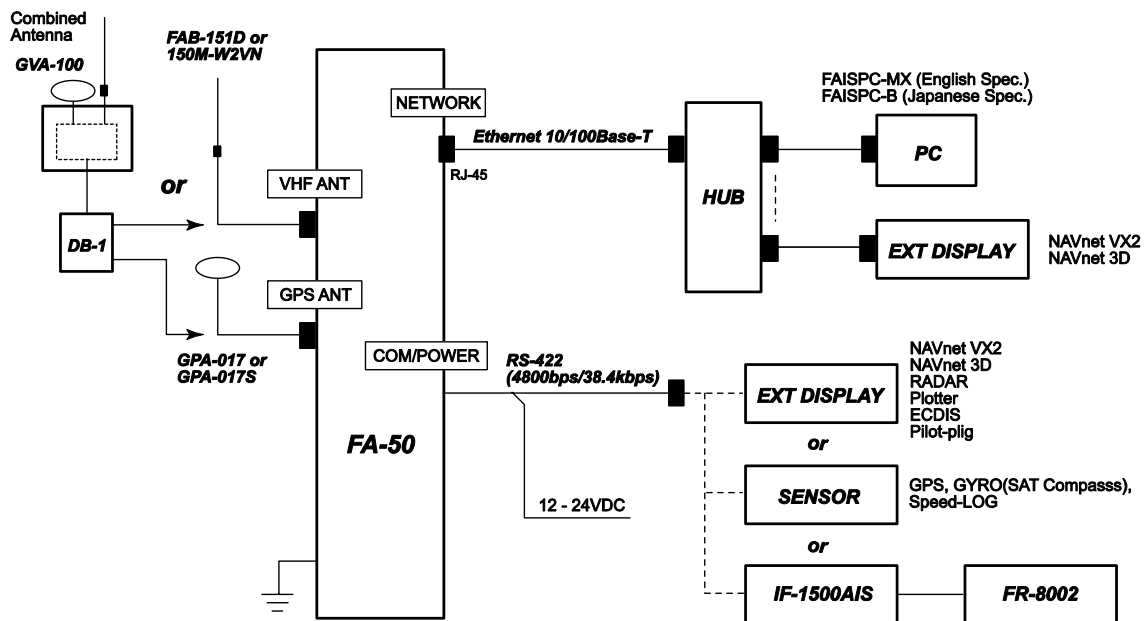

Figure 5.1.1 System Configuration Diagram of FA-50

The external input/output ports are provided as NETWORK (RJ-45) and COM/POWER.

The NETWORK port, which complies with Ethernet 10/100 BASE-T standard, is used to connect with external AIS display devices such as NAVNET and PC-MKD in the LAN.

The COM/POWER port is used for the power line and the I/O signal line. For use as the power supply line, 12 to 24 VDC input is connected, while an external display device, such as Radar, or a sensor is connected complying with RS-422 standard, for use as the signal line.

In the table below, IEC-61162 I/O data passing through the COM port and NETWORK port are described.

In addition to the sentences shown below, PFEC sentences are included.

Table 5.1.1 NMEA Input Data/Sentence Name

Data	Sentence name (priority)	Remarks
AIS alarm acknowledgment	ACK	
AIS interrogation request	(AIR)	Disabled, responded with transmission disabled (ABK)
Ship and voyage static data	SSD, VSD	
Datum reference data	DTM	
Position data	GNS>GLL>GGA>RMC	
Speed over ground (SOG) Course over ground (COG)	VBW>RMC>VTG>OSD	Use of VBW requires HDT.
Heading	HDT>OSD	Not supported by Furuno AD format.
RAIM display	GBS	
Request for area and sensor data	AIQ	
Date and time data	Internal ZDA>RMC> MSG4/11:UTC field	
DSC data	DSC, DSE	
Broadcast binary message	(BBM)	Disabled, responded with transmission disabled (ABK)
Safety-related broadcast binary message	BBM	Required to be sent in a fixed format.
Addressed binary message	(ABM)	Disabled, responded with transmission disabled (ABK)
Safety-related addressed binary message	(ABM)	Disabled, responded with transmission disabled (ABK)

Table 5.1.2 NMEA Output Data/Sentence Name

Data	Sentence name (priority)	Remarks
<ul style="list-style-type: none"> • AIS target display data • Handling of safety-related messages • Handling of external applications • System control 	AI VDM	Serial output sentences concerning received messages
<ul style="list-style-type: none"> • AIS target display data • Handling of safety-related messages • Handling of external applications • System control 	AI VDO	Serial output sentences concerning messages to be transmitted
Address binary	AI ABK	<ul style="list-style-type: none"> • Response to BBM • Incorrect input from external devices • Response to (AIR)(BBM)(ABM)
Regional CH assignment Msg.	AI ACA, AI ACS	ACS: Additional information of ACA
Alarm status	AI ALR	
Text transmission	AI TXT	

5.2 Block Diagrams

5.2.1 General

The FA-50 unit consists of the PWR board, RX1&RX2 boards, and MAIN&TX board.

Table 5.2.1 Boards function

Board	Main features
RX1 (05P0808A)	Converts the AIS Rx signals in a band of 150/160 MHz to the 1st IF signal in 51.136 MHz and further to the 2nd IF signal in 36 kHz; then output them to the MAIN&TX board. Equipped with Pre-AMP and a distributing circuit to distribute the Rx signals to the RX2 board. Not compatible with the RX2 board.
RX2 (05P0808B)	Converts the AIS Rx signals in a band of 150/160 MHz to the 1st IF signal in 51.236 MHz and further to the 2nd IF signal in 36 kHz; then output them to the MAIN&TX board. Not compatible with the RX1 board.
MAIN&TX (05P0814)	Consists of the functional components including system control, digital circuit of input/output interface, modulation/demodulation circuit, analog circuit of the transmission part which produces 1 W and 2 W outputs, power supply for the analog/digital circuits, and GPS receiver.
PWR (05P0809)	The power input of 12 to 24 VDC is converted by a switching regulator supply to provide +12 VDC output. It consists of the components including diode-protected reverse connection protection, input low-voltage protection & input over-voltage protection, output short-circuit protection device with a poly-switch.

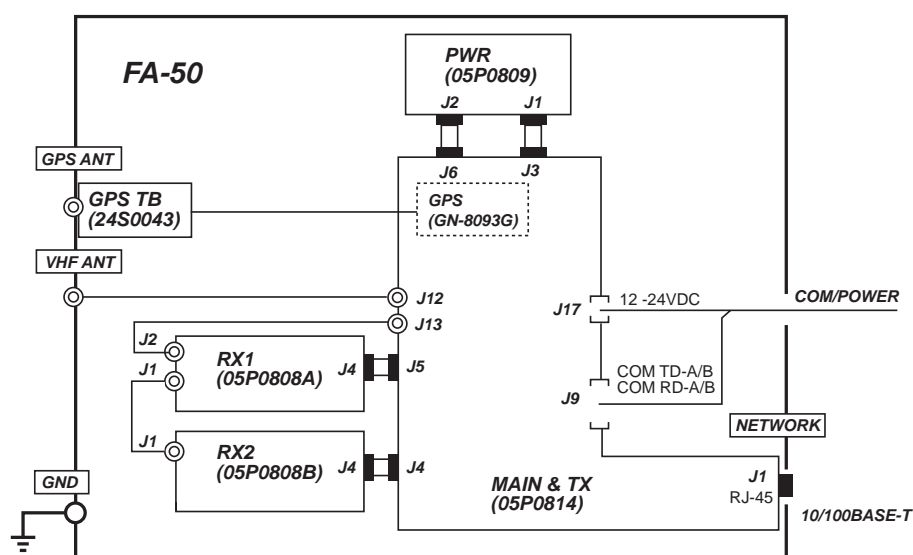

Figure 5.2.1 FA-50 Block Diagram

5.2.2 RX1, 2 Boards (05P0808A, B)

The RX1, 2 boards convert the AIS Rx signals in a band of 150/160 MHz to the IF signal in 36 kHz (2nd IF) to output to the MAIN&TX board.

Table 5.2.2 RX1, 2 Boards specifications

Item	Specifications
Rx Frequency	TDMA: 156.025 MHz to 162.025 MHz DSC: 156.525 MHz(CH70)
Rx Sensitivity	-107 dBm or less (PER: 20% or less)
DSC Rx Sensitivity (156.525MHz)	-107 dBm or less (BER: 10^{-2} or less)
High Input Rx Sensitivity	PER: 10% or less at -7 dBm input
Adjacent Channel Rejection Ratio	± 25 kHz, -31 dBm or greater (PER: 20% or less)
Inter-modulation Product Ratio	± 50 kHz, ± 100 kHz, -36 dBm or greater (PER: 20% or less)
Sensitivity Suppression	± 500 kHz, -23 dBm or greater (PER: 20% or less) ± 1 MHz, -23 dBm or greater (PER: 20% or less) ± 2 MHz, -23 dBm or greater (PER: 20% or less) ± 5 MHz, -15 dBm or greater (PER: 20% or less) ± 10 MHz, -15 dBm or greater (PER: 20% or less)
Antenna Impedance	50 Ω
1st IF	RX1: 51.136 MHz RX2: 51.236 MHz
2nd IF	36 kHz
PLL Reference Frequency	RX1: 25.55 MHz ± 1 ppm RX2: 25.6 MHz ± 1 ppm
1st Local Frequency	RX1: Fo+51.136 MHz RX2: Fo+51.236 MHz
2nd Local Frequency	RX1: 51.1 MHz RX2 : 51.2 MHz

1. RX1 Board (05P0808A)

The Rx signal from the antenna is passed through BPF of 156 to 162 MHz composed in L/C and entered to Pre-AMP in Q1 to be amplified by 6dB or so. This output signal is divided to the RX1 and RX2 receipt circuits by T1.

U1 is a 1st IF conversion circuit. The receipt frequency: Fo in 152 to 162 MHz and the 1st Lo frequency Fo + 51.136 MHz of PLL synthesizer output are mixed and a 51.136 MHz component of the 1st IF signal is extracted at the next stage: FL1.

The 1st IF signal is passed through the IF amplification circuits in Q6, FL2, and Q8; then inputted to the 2nd IF frequency conversion circuit of U7. In the 2nd IF frequency conversion circuit, the Y1: 25.55 MHz reference oscillator and the 2nd Lo signal doubled in Q11 are mixed and passed through 36 kHz LPF composed in U6 at the next stage; then the 2nd IF signal of 36 kHz is extracted to be outputted to the MAIN&TX board.

The 36 kHz signal output is inputted to the AGC circuit consisting of Q12, CR6, U9, and Q13. Q13 output of the AGC circuit controls CR4: a pin diode as well as a gain of Q8. AGC is controlled by the receipt input of -50 dBm or greater.

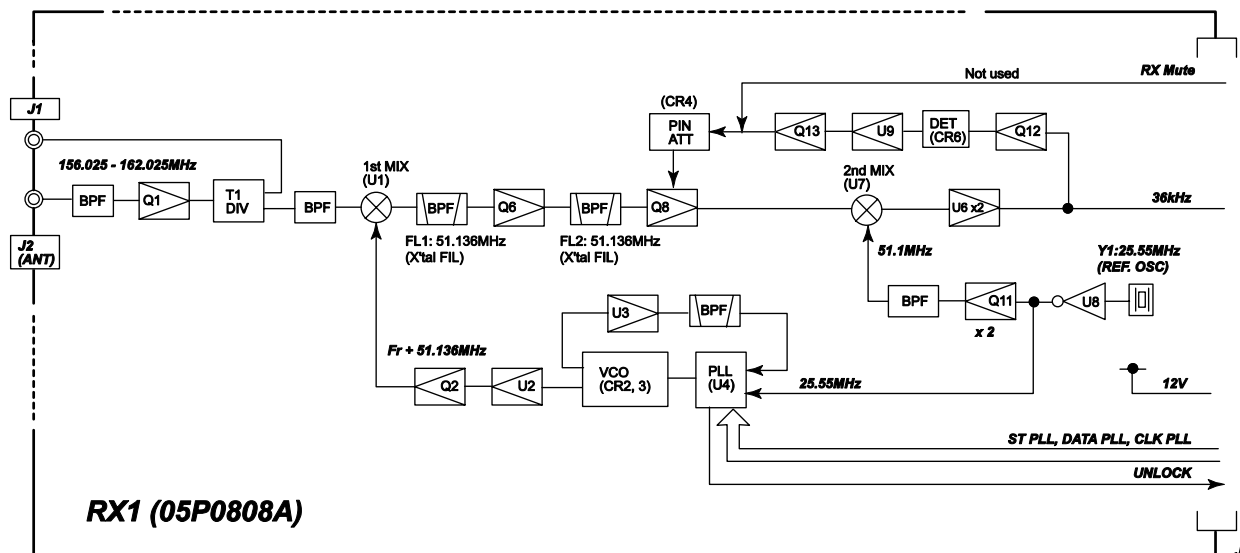

Figure 5.2.2 RX1 Block Diagram

2. RX2 Board (05P0808B)

The signal divided from the Rx signal in RX1 is inputted. The circuit structure of RX2 is same as RX1 except that the 1st IF signal is in 51.236 MHz. Accordingly, the local oscillator frequency and IF FILs are different.

Table 5.2.3 Major Differences of RX1, 2 Boards

Difference	RX1 board	RX2 board
Y1: Reference frequency	25.55 MHz \pm 1 ppm	25.6 MHz \pm 1 ppm
1st Lo frequency	Fo + 51.136 MHz	Fo + 51.236 MHz
2nd Lo frequency	51.1 MHz	51.2 MHz

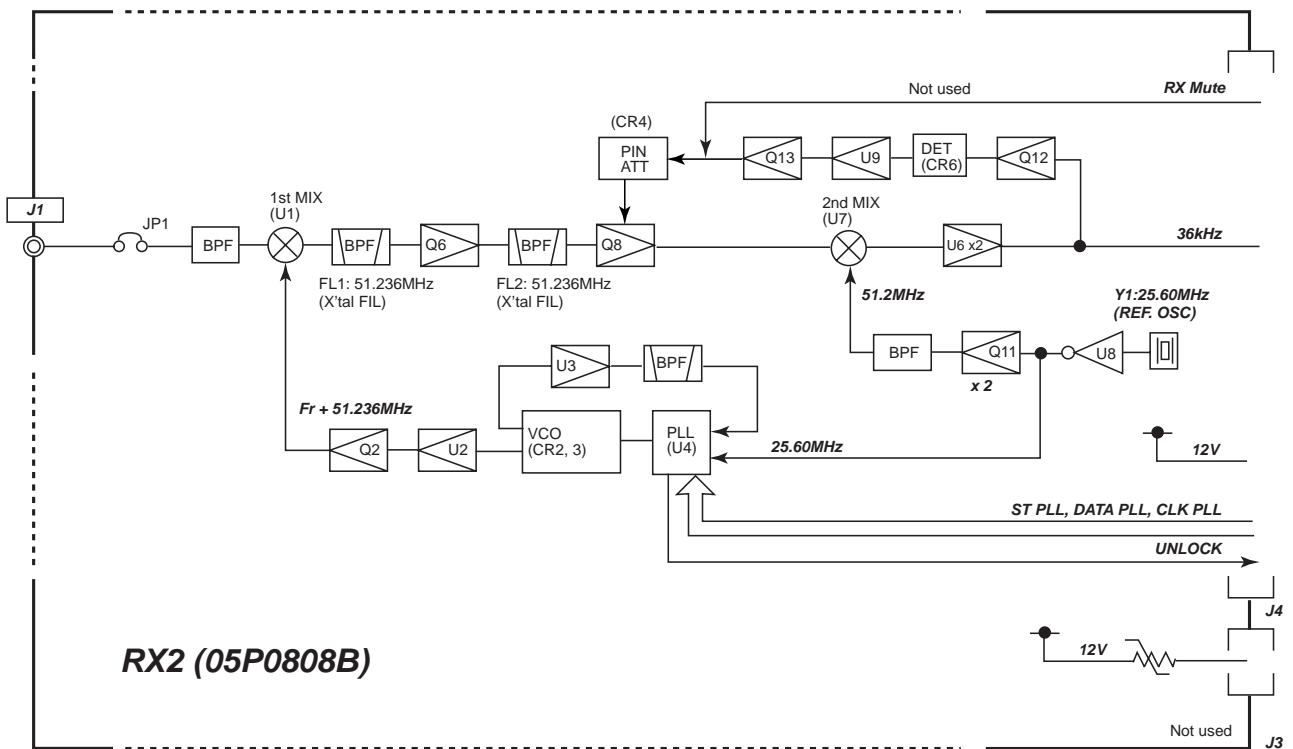

Figure 5.2.3 RX2 Block Diagram

5.2.3 MAIN&TX Board (05P0814)

The MAIN&TX board consists of the functional components including system control, digital circuit of input/output interface, modulation/demodulation circuit, transmission circuit, power supply circuit, and GPS receiver.

1. MAIN Circuit

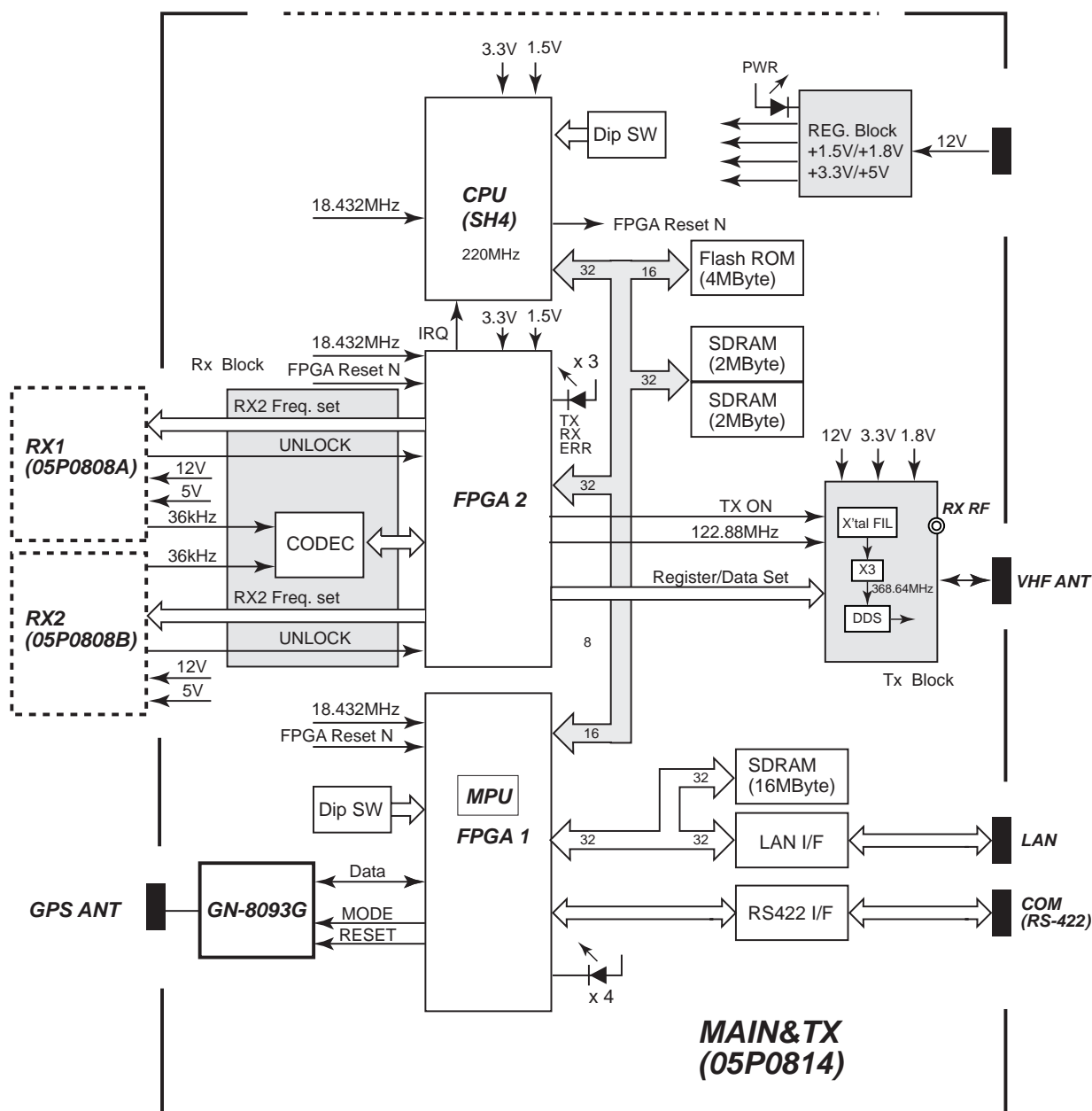

Figure 5.2.4 Digital Circuit Diagram

The digital circuit consists of CPU, FPGA 1, FPGA 2, and their peripheral circuits. Main functions are described below.

Table 5.2.4 Main Functions of Digital Block

Component	Function
CPU	<ul style="list-style-type: none"> • Demodulation of IF signal sample data • Data backup
FPGA 1	<ul style="list-style-type: none"> • Slot generation • PLL setting • CPU function <ul style="list-style-type: none"> - Transmission control of Class B messages - Output AIS receipt data - Area control - Communication with the external units - Handling of sensor inputs signal • CPU peripheral circuit <ul style="list-style-type: none"> - LAN interface LAN controller: LAN91C111 [SMSC] 10/100 Base-T supported - Serial interface (GPS, COM port) Asynchronous serial baud rate 4800/38400 bps 8-n-1 Transmission: RS-422, Receipt: RS-422/IEC61162-1 • Transmission/receipt data coding (NRZi/HDLC)
FPGA 2	<ul style="list-style-type: none"> • Receipt processing <ul style="list-style-type: none"> - CODEC interface - Digital filter - S-LEVEL detection - Carrier sense feature • Transmission processing <ul style="list-style-type: none"> - Generate DDS reference clock - DDS interface (modulation of transmission data)

Table 5.2.5 Functions of Panel LEDs

LED	Color	Function
POWER	Green	Power ON indicator, which lights up at power ON.
ERROR	Red	Error indicator, BITT error (controlled by SH-4) Lights up when an error in ROM/RAM or the Tx circuit is detected.
RX	Yellow	AIS message Rx indicator, which lights up for 50msec at AIS message reception (controlled by FPGA 2)
TX	Blue or Yellow	Blue: AIS message Tx indicator, which lights up for 1 sec or longer at AIS transmission (controlled by FPGA_2) Yellow: Blinking at TX Time out (Tx error indicator), blinking in a cycle of 200 msec when transmission fails 2 or more times. Lights up orange when an unregistered MMSI detected.

2. TX Circuit

In the TX circuit block diagram shown below, and the TX signal is GMSK modulated signal.

This signal is used to generate an AIS message by controlling DDS from FPGA 2. The “TX” signal passes through BPF in 150/160MHz, is amplified in Q5 and Q4 and finally generates a 2 W or 1 W output. The Tx output power is adjusted by R24 to produce an output of 2 W.

While monitoring the Tx output power, when a Tx error is detected, for example, in the case where Tx output power is detected in spite of no transmission performed or where Tx output power is not detected in spite of transmission performed, the ERROR LED (red) lights up.

Tips: Adjustment at factory (No adjustment in field)

- R25 can be adjusted so as to place a voltage of 45 mV between both ends of R41 (1Ω) (between TP15 and 20) by a bias adjustment of Q5.
about 1 VDC at 2 W output power
- R404 can be adjusted so as to place a voltage of 20 mV between both ends of R338 (0.33Ω) (between TP19 and 20) by a bias adjustment of Q4.
about 150 mVDC at 2 W output power
- R24 can be adjusted so as to produce an output of 2 W by an adjustment of the Tx output power.

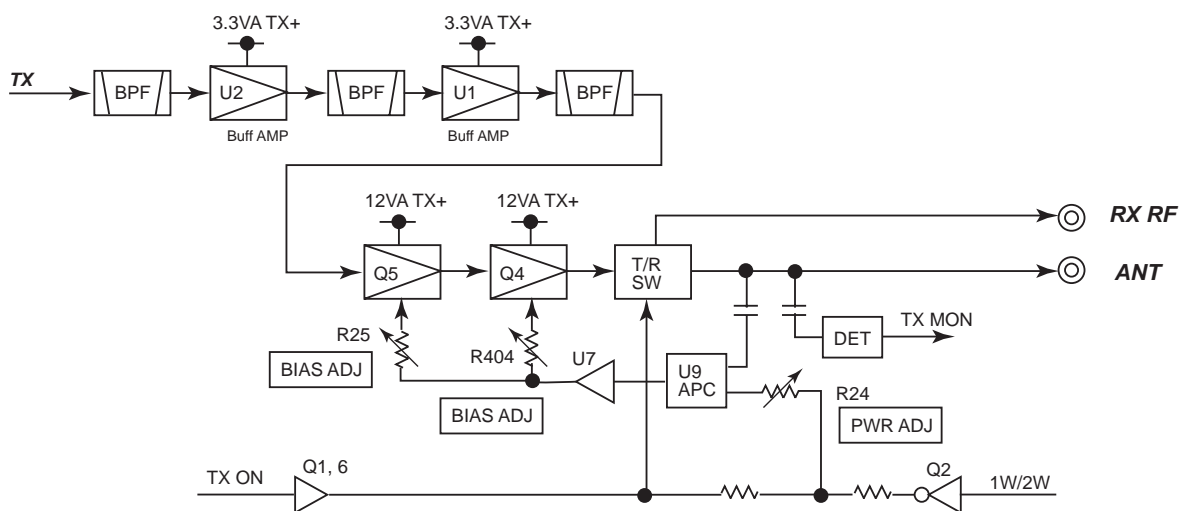

Figure 5.2.5 TX Circuit

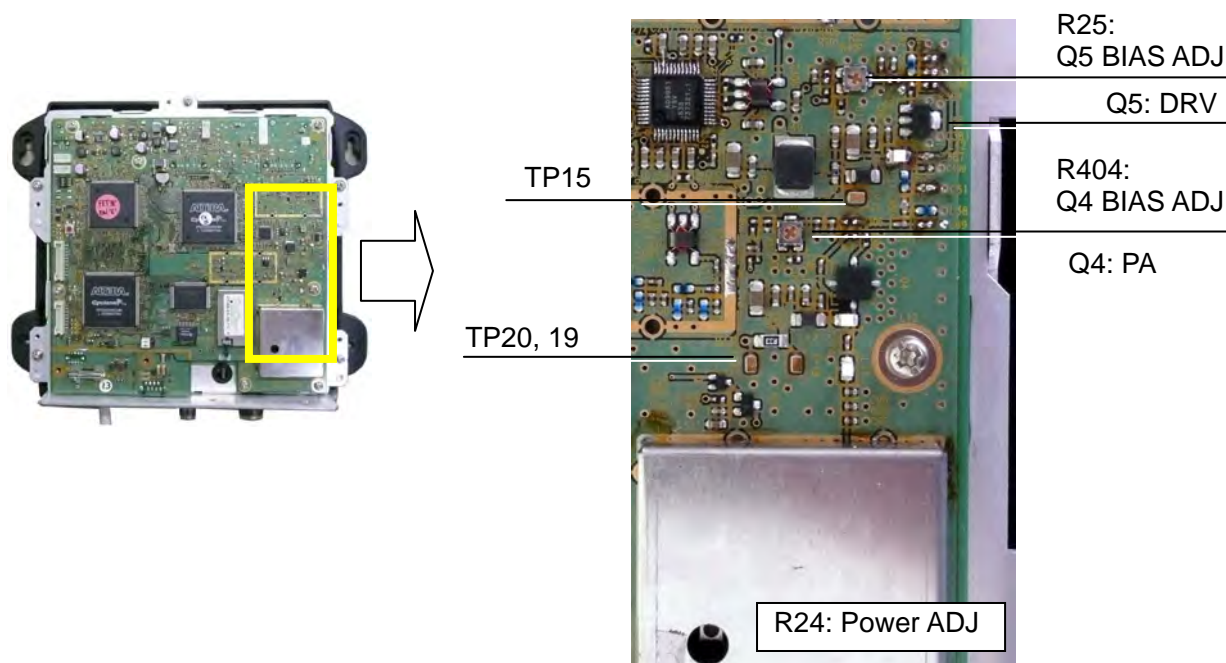

Figure 5.2.6 Locations where transmission adjustment is made

3. SW REG Circuit

The voltage of 12 VDC from the PWR board is converted on the MAIN&TX board to provide various power voltages required in individual circuits.

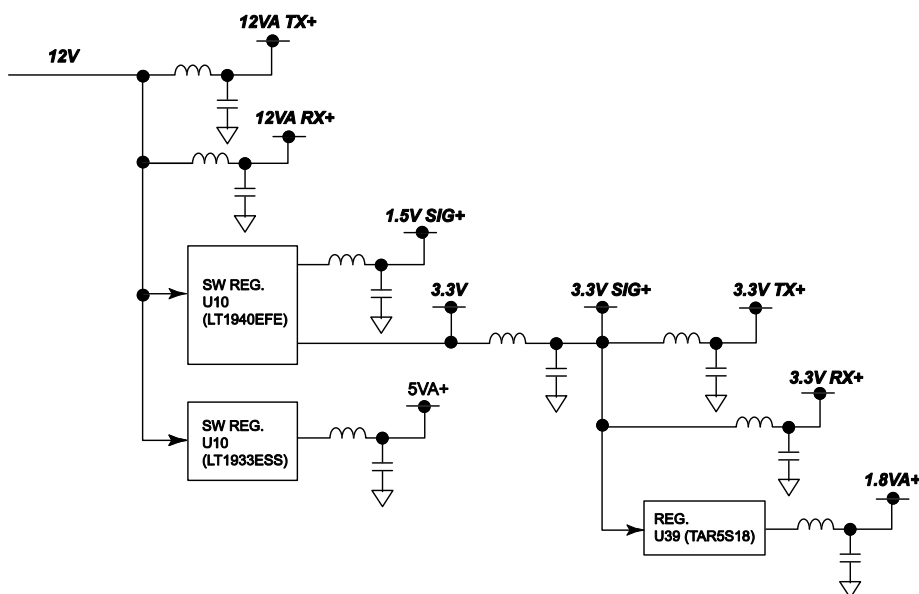

Figure 5.2.7 Power Circuit

5.2.4 PWR Board (05P0809)

The power input of 12 to 24 VDC is converted by a switching regulator supply to provide +12 VDC output.

Table 2.5.6 PWR Board specifications

Item	Specifications
Input Voltage	12 to 24 VDC (+9.6 to +31.2 VDC)
Rated Output Voltage	12.0 VDC \pm 5 %, Ripple voltage 100 mVp-p
Current Consumption	2.0 to 1.0 A
Output Current: at the Tx state	1.5 A (0.8 A at the Rx state)
Switching Frequency	200 kHz (170 kHz to 230 kHz), not adjusted
Efficiency	75 % at least
Output Short-circuit Protection	At output short-circuit, protected by a blown fuse or polyswitch
Input Reverse-connection protection	At input reverse-connection, protected by a blown fuse
Input Low-voltage Protection	The power supply turns off at an input voltage of +6 to 9 VDC.
Input Over-voltage Protection	The power supply turns off at an input voltage of +34 to 38 VDC.

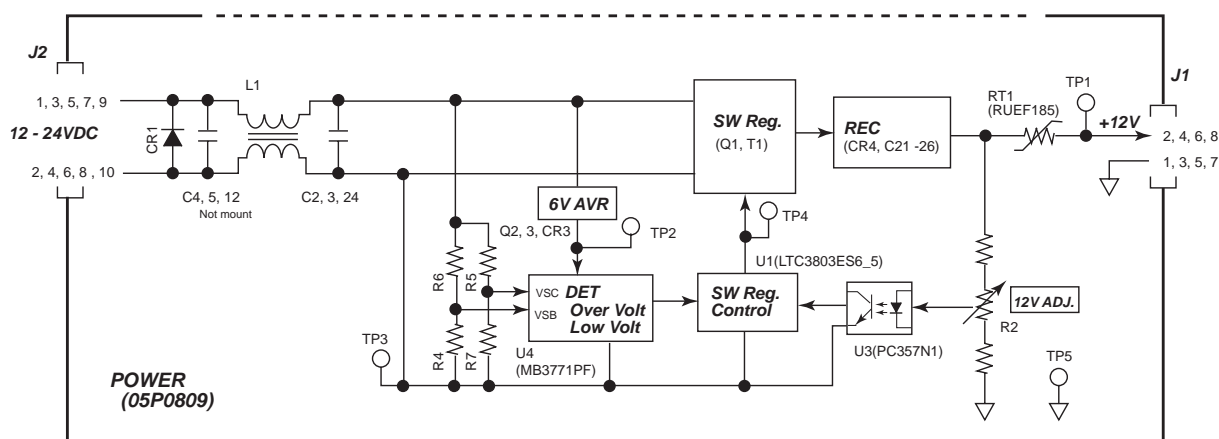

Figure 5.2.8 Block Diagram of POWER Board

The power input ranging from 12 to 24 VDC is passed through the power supply reverse-connection protection diode in CR1 and the common mode filter in L1 and then inputted to the switching regulator circuit. U1 drives Q1 using switching regulator control IC. When an out-of-range power supply voltage is detected in the input low-voltage/over-voltage detection circuit, U4 controls U1 (switching regulator control) to turn off.

An adjustment of switching power output is made to provide an output of +12 VDC by adjusting R2.

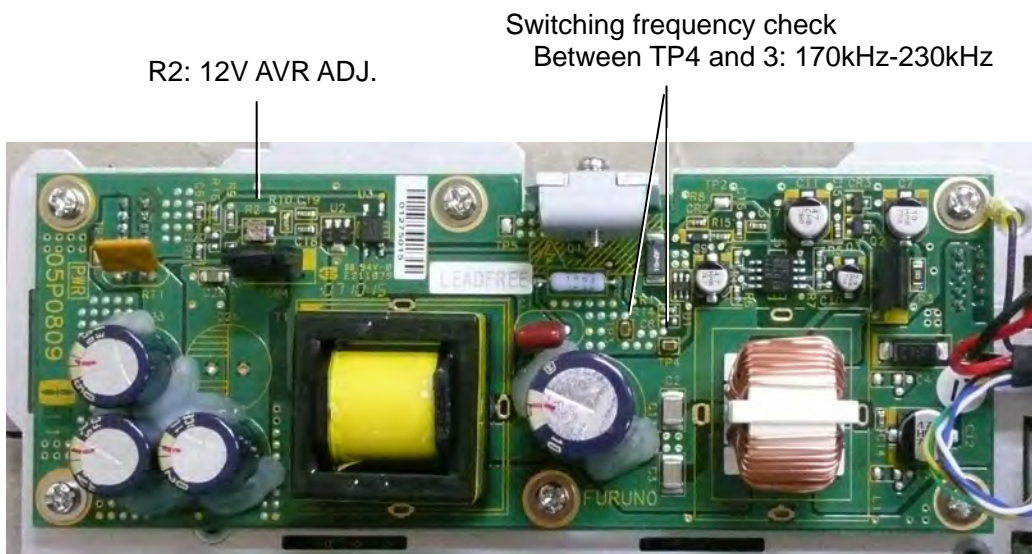

Figure 5.2.9 POWER Board

Chapter 6. Updating Program

6.1 Updating Program

6.1.1 Preparation of Update

1. Connections

When updating the program, the PC and FA-50 should be connected via HUB in the LAN connection. As a LAN cable, a straight cable should be used.

Note: When LAN connection between the PC and FA-50 is not interfaced by HUB, a cross cable should be used. Refer to page 6-6.

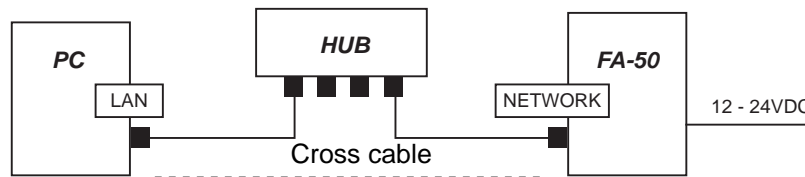
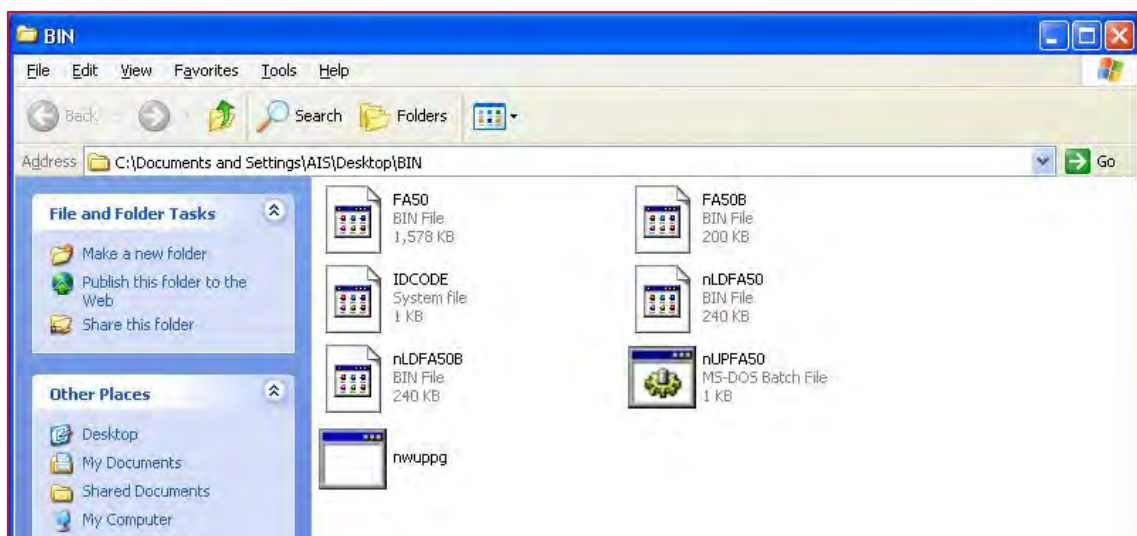

Fig. 6.1.1 Connections

2. Program files

The last two letters “xx” of the program folder name, UPFA50_01xx indicate the detail version. Files in the program holder are as follows.

- FA50: application file
- FA50B: boot program file
- IDCODE, nLDFAS0, nLDFAS0B, nwuppg, nUPFA50: file for updating program



6.1.2 Procedure

To update the program, first of all, you should open the Web browser screen of FA-50 and do below;

- Select “*For Service -> CLEAR MEMORY*” to open the CLEAR MEMORY menu, where click and run Factory Reset.
- Select “*For Service -> Version*” to open the Version menu, where check the program version.

To access the For Service menu, Password : xxxxxx must be entered. This Password is same as that of FS-2570. Refer to Furuno Information FQ4-2009-014.

Step-1

1. Download the program folder of FA-50 to PC.
2. Select “Network connection” from the start menu on PC, select “Local area connection” and open the property.
3. Select “Internet protocol (TCP/IP)” in [General] tag and click “Property” button.
4. Place a checkmark to the left of “Use the following IP address option (S)” and enter the IP address and the subnet mask. The setting of Default Gateway is not required.
 - IP address: 172.31.1.1
 - Subnet mask: 255.255.0.0

Note: The default IP address of FA-50 is predefined with 172.31.24.3. Therefore, the IP address to be set on the PC should be 172.31.xxx.xxx except 172.31.24.3 so as to establish LAN connection with FA-50.

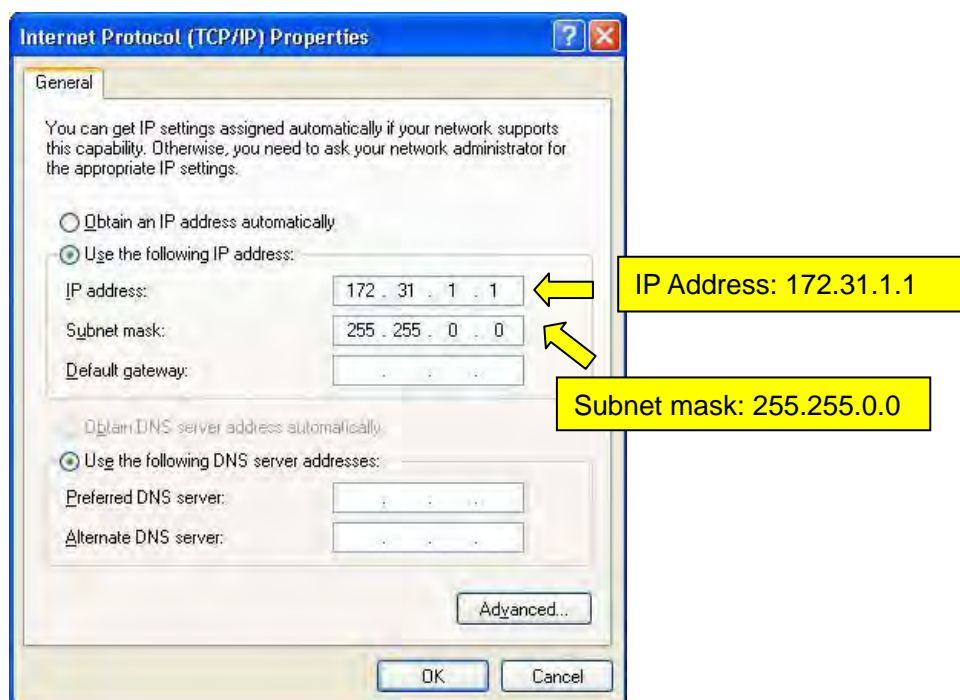

Step-2

5. Turn off the power of FA-50.
6. Connect the PC and FA-50 via HUB in the LAN connection.
7. Open the program folder and double-click the Batch file “nUPFA50”. The following Command prompt window appears.

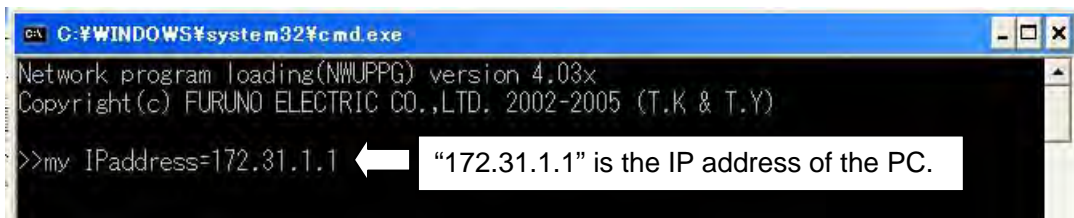

```

C:\WINDOWS\system32\cmd.exe
Network program loading(NWUPPG) version 4.03x
Copyright(c) FURUNO ELECTRIC CO.,LTD. 2002-2005 (T.K & T.Y)
>>my IPaddress=172.31.1.1

```

8. Turn on the power of FA-50. Within about 10 seconds, a message appears saying “P0>connection IPaddress=172.31.24.3”.



```

C:\WINDOWS\system32\cmd.exe
Network program loading(NWUPPG) version 4.03x
Copyright(c) FURUNO ELECTRIC CO.,LTD. 2002-2005 (T.K & T.Y)
>>my IPaddress=172.31.1.1
P0>connection IPaddrss=172.31.24.3

```

9. Within 10 seconds or so after the message: “P0>connection Ippaddress=172.31.24.3” appears on the screen, uploading of a boot program for applications automatically starts and, when finished, a message saying “P0>finish upload program. (size=204xxx)” appears. The upload completes within 20 seconds or so.

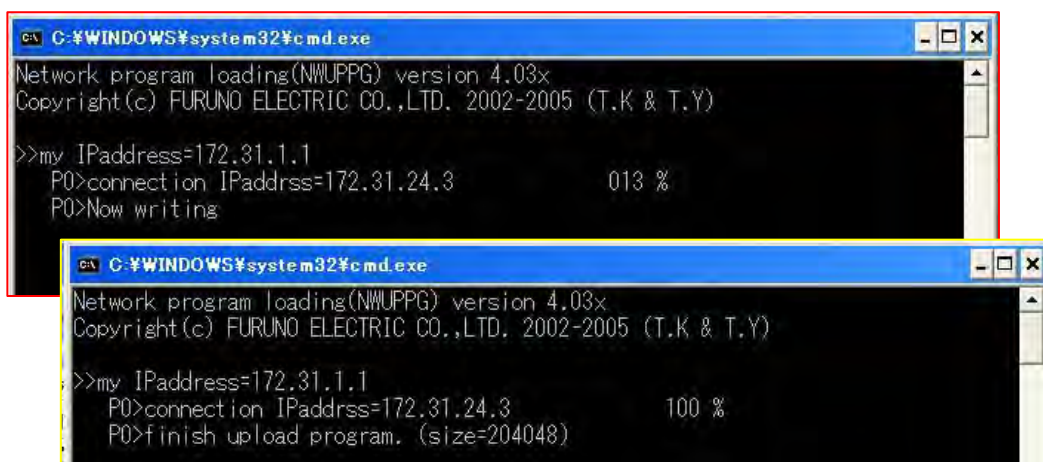

```

C:\WINDOWS\system32\cmd.exe
Network program loading(NWUPPG) version 4.03x
Copyright(c) FURUNO ELECTRIC CO.,LTD. 2002-2005 (T.K & T.Y)
>>my IPaddress=172.31.1.1
P0>connection IPaddrss=172.31.24.3      013 %
P0>Now writing

C:\WINDOWS\system32\cmd.exe
Network program loading(NWUPPG) version 4.03x
Copyright(c) FURUNO ELECTRIC CO.,LTD. 2002-2005 (T.K & T.Y)
>>my IPaddress=172.31.1.1
P0>connection IPaddrss=172.31.24.3      100 %
P0>finish upload program. (size=204048)

```

10. Within a few seconds after the message: “P0>finish upload program. (size=204xxx)” appeared, the messages of “P0>connection Iaddress=172.31.24.3” and “P0>finish upload program. (size=204xxx)” disappear, and only a message saying “>>my Iaddress=172.31.1.1” is displayed on the screen.
11. “P0>connection Iaddress=172.31.24.3” message appears within a few seconds. And after about 15 seconds, uploading of the application program automatically starts. When finished, “P0>finish upload program. (size=1615xxx)” message appears. Updating program is completed within approximately 20 seconds.

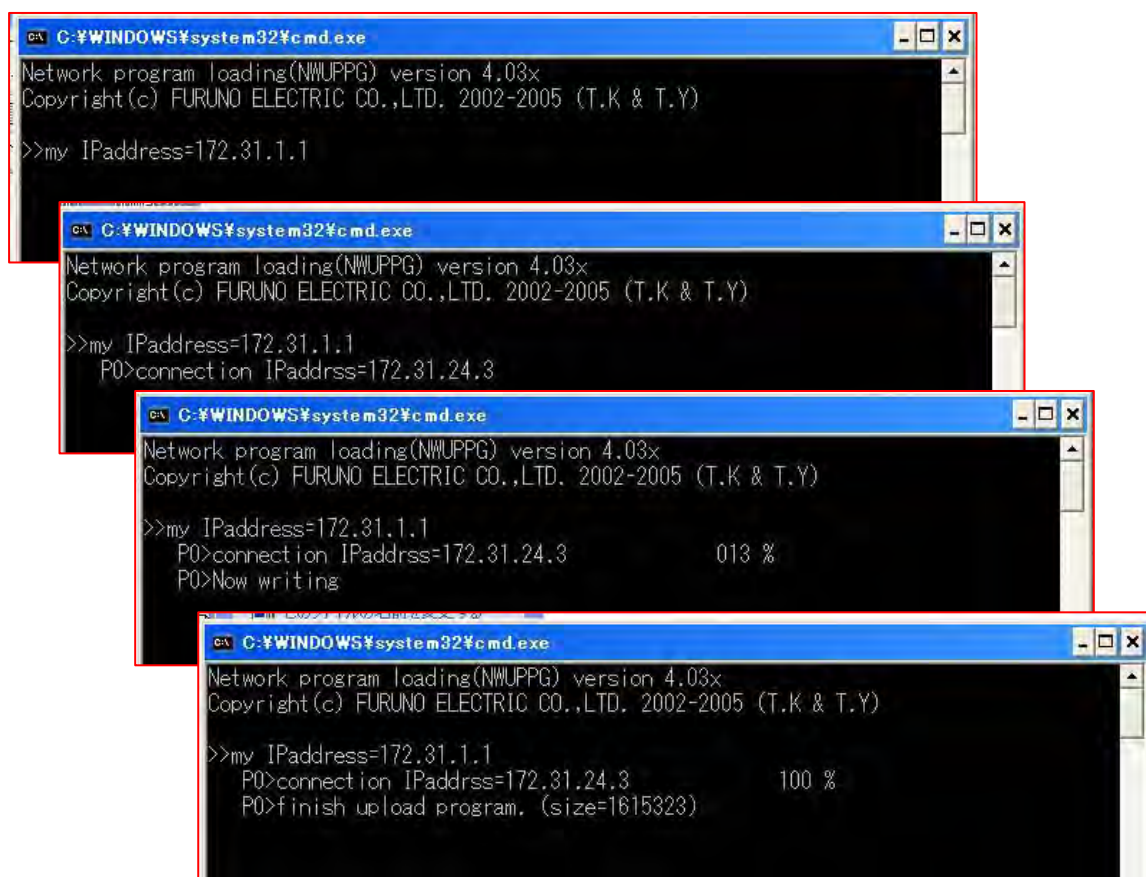

12. When a message saying “Press any key to continue ...” appears, press the [Enter] key. The Command prompt screen closes.

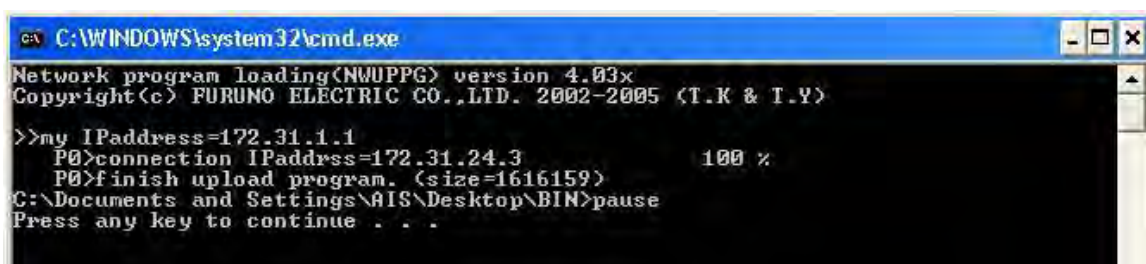

Reference 1:***When the program update is failed***

To update the program, turn ON the power of FA-50. Then the updating starts automatically. If the update does not start even after 10 seconds or longer have elapsed, LAN connection (communication) between the PC and FA-50 has failed. Check the connection and reboot the PC and HUB to retry. See connection error shown below.

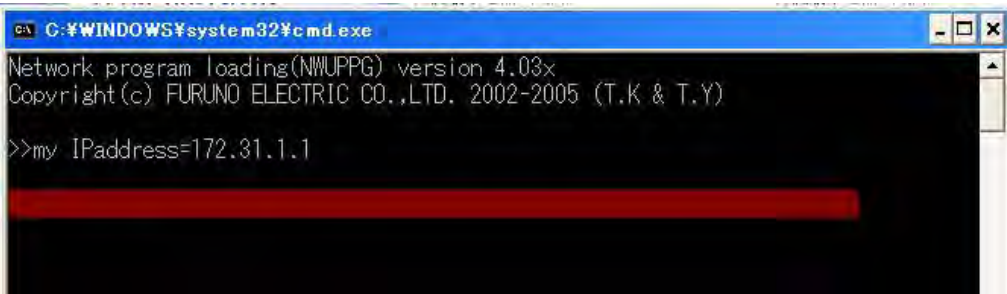
Connection error

```
C:\WINDOWS\system32\cmd.exe
Network program loading(NWUPPG) version 4.03x
Copyright(c) FURUNO ELECTRIC CO.,LTD. 2002-2005 (T.K & T.Y)
>>my IPaddress=172.31.1.1
```

Program writing error

```
C:\WINDOWS\system32\cmd.exe
Network program loading(NWUPPG) version 4.03x
Copyright(c) FURUNO ELECTRIC CO.,LTD. 2002-2005 (T.K & T.Y)
>>my IPaddress=172.31.1.1
P0>connection IPaddrss=172.31.24.3 100 %
C:\Documents and Settings\nyokoyama\デスクトップ\UPFA50_0102\BIN>pause
Press any key continues....
```

Reference 2:**Procedure to update when HUB is not available**

Basically, a program update should be performed with the LAN connection established between the PC and FA-50 via HUB. If the HUB is not available, however, you can follow the steps described below:

Procedure

1. Connect between the PC and FA-50 with a cross cable.
2. Open the program folder and double-click the Batch file “nUPFA50”. The following Command prompt window appears.

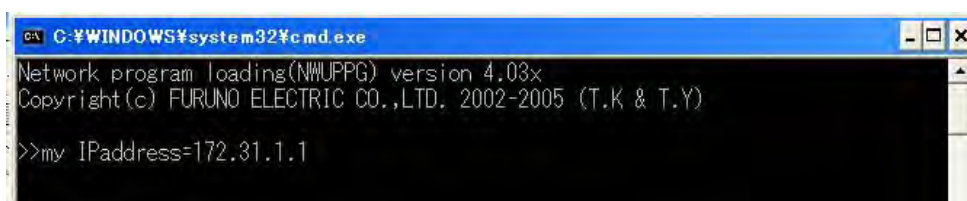

```

C:\WINDOWS\system32\cmd.exe
Network program loading(NWUPPG) version 4.03x
Copyright(c) FURUNO ELECTRIC CO.,LTD. 2002-2005 (T.K & T.Y)
>>my IPAddress=172.31.1.1

```

3. Within a second, power OFF/ON the FA-50.
If the update does not start even after 10 seconds or longer have elapsed, an error message is displayed as below. Power OFF/ON the FA-50 again. Depending on the timing, the update can be started.
Connection error between FA-50 and the PC

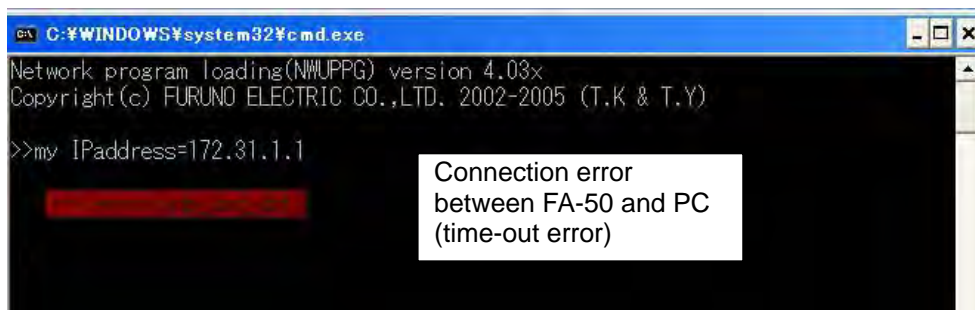

```

C:\WINDOWS\system32\cmd.exe
Network program loading(NWUPPG) version 4.03x
Copyright(c) FURUNO ELECTRIC CO.,LTD. 2002-2005 (T.K & T.Y)
>>my IPAddress=172.31.1.1

```

Connection error
between FA-50 and PC
(time-out error)

4. The update is completed when a message saying “P0>finish upload program. (size=1615xxx)” appears on the screen.
5. When a message saying “Press any key to continue ...” appears, press the [Enter] key. The Command prompt screen closes.

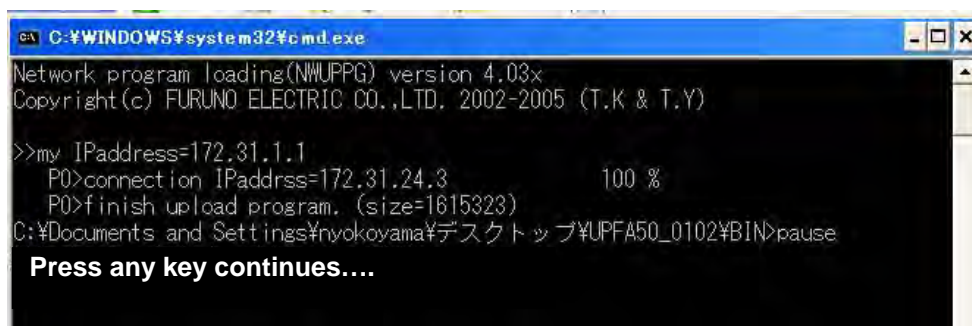

```

C:\WINDOWS\system32\cmd.exe
Network program loading(NWUPPG) version 4.03x
Copyright(c) FURUNO ELECTRIC CO.,LTD. 2002-2005 (T.K & T.Y)
>>my IPAddress=172.31.1.1
P0>connection IPAddrss=172.31.24.3 100 %
P0>finish upload program. (size=1615323)
C:\Documents and Settings\myokoyama\デスクトップ\UPFA50_0102\BIN>pause

```

Press any key continues....

6.1.3 After updating

1. Execute Memory Clear

Executing Memory Clear restores the factory default settings.

Before executing Memory Clear, take notes of the set values of “Ship Static Edit” in the [Initial Setup] menu to use them to reset later.

Procedure:

1. Start Internet Explorer and enter “http://172.31.24.3” in the URL field to open the Web browser screen of FA-50.
2. Execute the steps as follows:
Service -> Password input -> Memory Clear -> Factory Reset.

Reference:

- **Factory Reset without IP Address:**

The setting values excluding those of “Network Setup” in “Initial Setup” are restored to the factory defaults.

- **Factory Reset:**

All of the set values are restored to the factory defaults.

2. Check the Program Version

Check it from the Web browser screen of FA-50.

Procedures:

1. Start Internet Explorer and enter “http://172.31.24.3” in the URL field to open the Web browser screen of FA-50.
2. Execute For Service -> *Password input:xxxxxx* -> Version to open the menu, where check the program version.



The screenshot displays the 'FA-50/Service/Version' menu. It features a table with four rows of information: Version, CPU 1, CPU 2, and FPGA. Each row contains a component name, its version number, and a corresponding identification number. Below the table, there is a '<<Service Menu' link and the 'FURUNO' logo.

FA-50/Service/Version		
Version	0550233-01.02	
CPU 1	X1.105.B1.14	200806061154
CPU 2	Y2.27 3ch	200803051756
FPGA	01.00	20071123

<<Service Menu

FURUNO

7.1 Overview

You can control the Tx output power manually either by operating from the menu in the Web browser screen of FA-50 or by setting [S2] on the MAIN&TX board of FA-50 to ON.

Whichever method you choose, this procedure must be completed within 15 seconds. When 15 seconds has passed, the transmission automatically terminates.

7.1.1 Connecting Measurement Devices

A power meter with a load of 50Ω is connected to the [VHF ANT] terminal of FA-50. As shown in the figure below, frequency measurement is performed in such a manner where an output of the pickup coil of 5 to 10t of wire wound around the antenna coaxial cable is entered to the frequency counter.

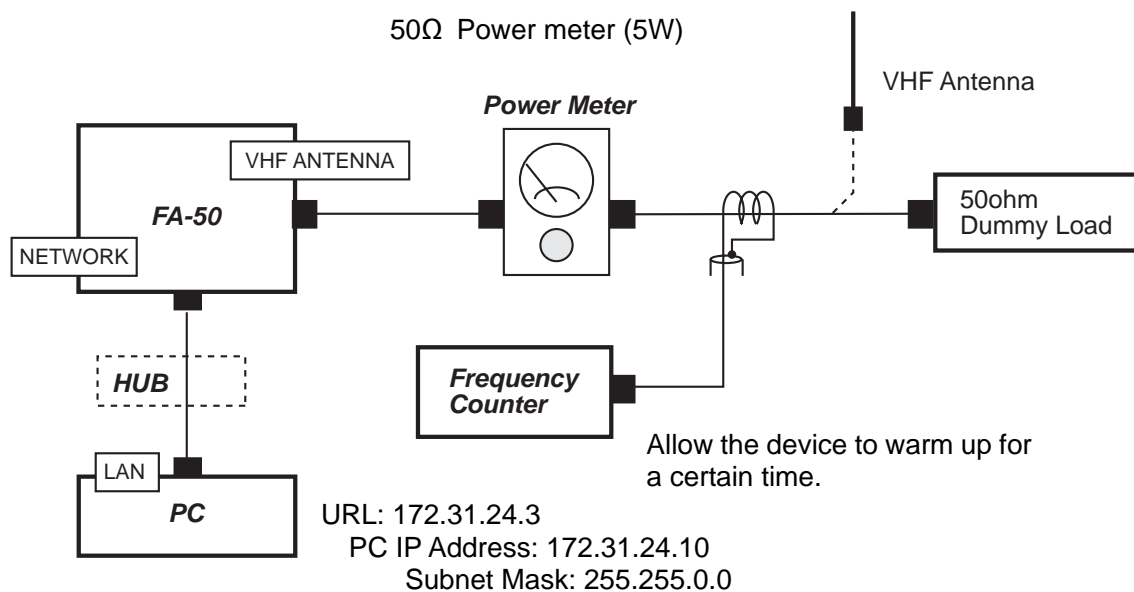

Note:

Between PC and FA-50: LAN Cross cable
Between PC, HUB and FA-50: LAN Straight cable

Figure 7.1.1 Connecting Measurement Devices

7.2 Measurement of Tx Output Power and Frequency

7.2.1 Transmission Control from Web browser Screen

Procedures

1. Connect measurement equipment (a power meter, a frequency counter) and a PC with the FA-50.
2. After powering up the FA-50, establish a LAN connection between the PC and FA-50 and open the Web browser screen of FA-50.

Tip: To open the Web browser screen, enter “172.31.24.3” in the URL field.



3. Select [For Service] and enter a password in the Password field; then click [Login] to proceed to the [For Service] menu.

In this case, “xxxxxx” should be entered in the Password field. This is the same as what required when making System settings of GMDSS equipment such as FS-2570.

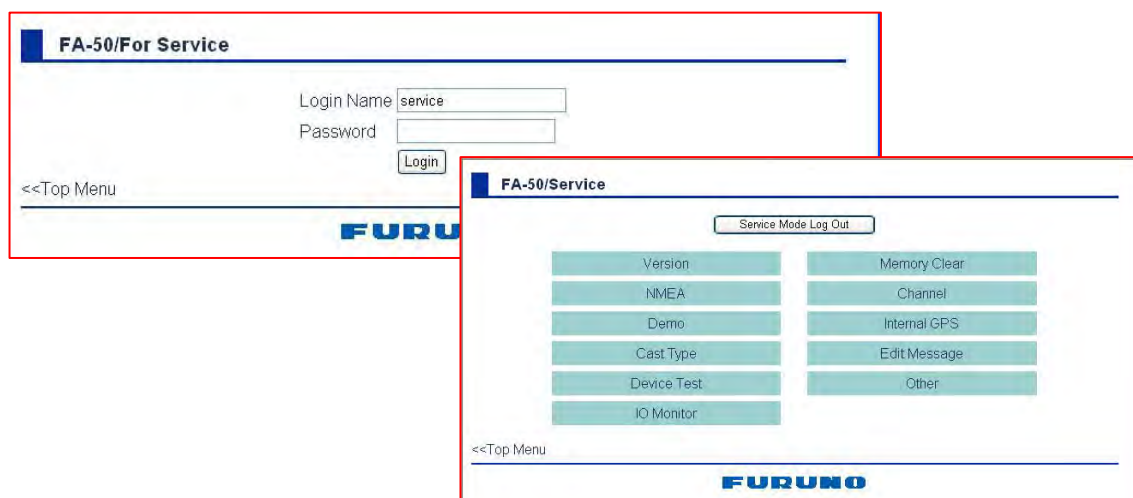

- From the [For Service] menu, open the [Channel] screen and specify a Tx channel and a Tx output power. The Tx channel should be specified in the [RX1] field. The Tx output power should be specified in the [TX Power] field. When completing the settings above, in the [Channel Selection], switch the setting from “Auto” to “**Manual**” and click [OK].

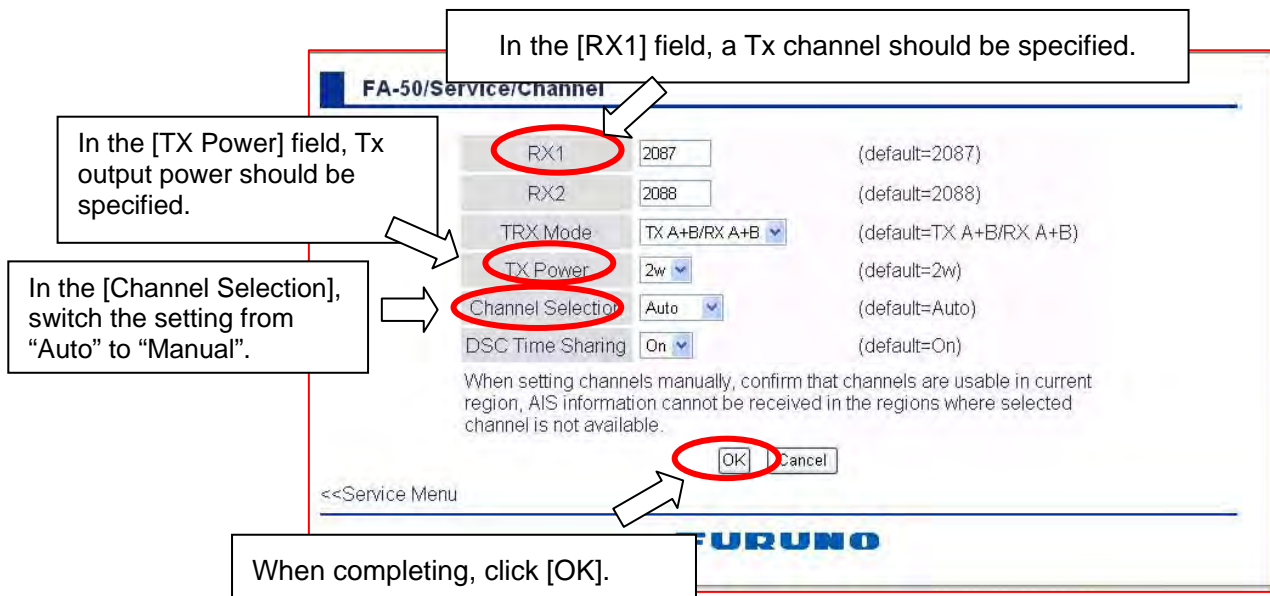

- Return to the [For Service] menu and open the [Device Test] menu.
- Press the [Select] button in the “TX Test” screen and select a modulated signal from the pull-down menu. In this case, select a non-modulated signal: “**Carrier**” and click [OK].

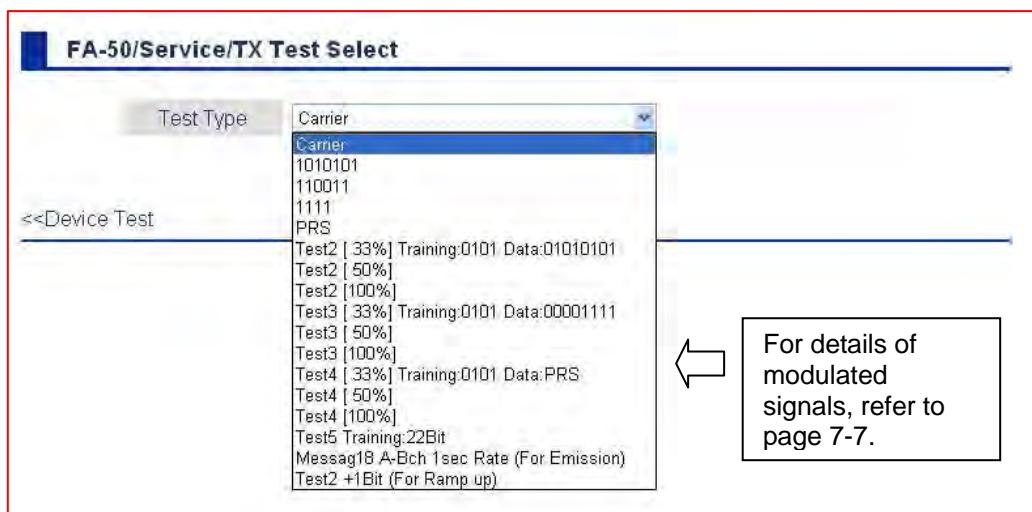

- Click the [Start] button in the “Tx Test” screen. The “Tx Test” screen changes. Click [Start] to start a transmission, [Stop] to stop the transmission. The Tx output power automatically turns off within 15 seconds. Therefore, measurement of the Tx output power and frequency must be finished within 15 seconds.

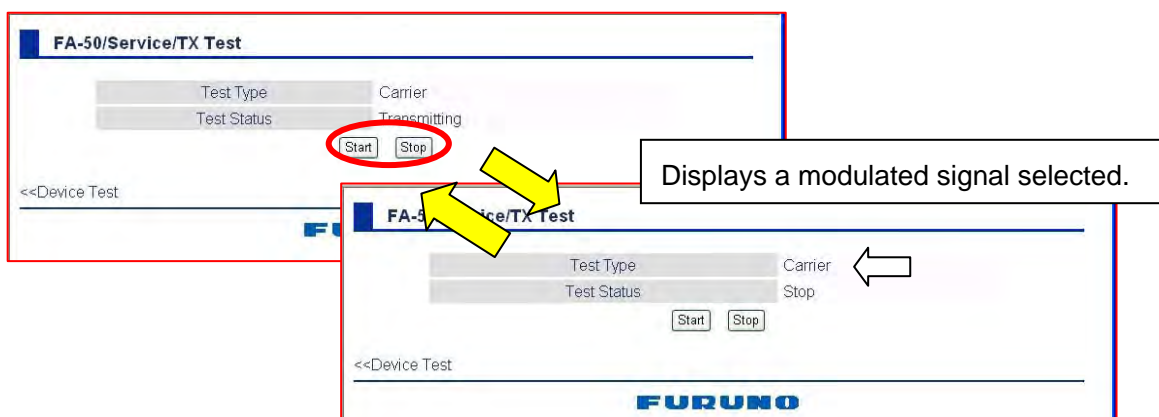

- Tx output power standard:
1 W, 2 W \pm 1.5 dB (IEC62287 standard) about +40%.
- Frequency deviation:
 \pm 500 Hz

- To change the channel or Tx output power of the other channel, return to the step 4 and continue.
- When completing the measurements, open the [Channel] screen from the [For Service] menu, where switch the setting of [Channel Selection] from “Manual” to “Auto” and click [OK].

Tips:

If the Channel Selection is left unchanged as “Manual”, the settings of Tx Mode, Channel, and Tx Power specified in the [Channel] menu are effective in the FA-50 operation.

Accordingly, even when MSG. 22, 23, containing the regional operation area setting managed from VTS, are received, the system should operate with the Manual setting values and cannot receive signals from other ships and VTS.

To confirm the currently-operating channel and the Tx output power, go to the [Own Vessel Data] screen from the Top menu.

7.2.2 Transmission Control by S2 on MAIN&TX Board

Procedures

1. Connect measurement equipment (Power meter, Frequency counter) and PC with the FA-50.
2. Remove the cover of FA-50.
3. Turn ON S2. While the transmission state is kept for 15 seconds, measure the Tx output power and the frequency.

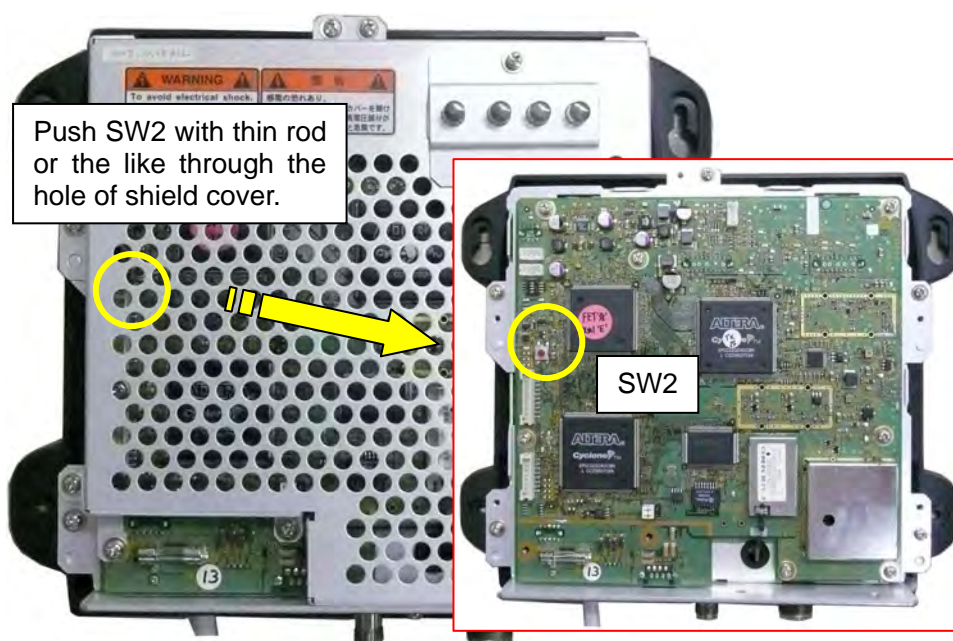

- Tx output power standard:
1 W, 2 W \pm 1.5 dB (IEC62287 standard) about \pm 40%.
- Frequency deviation:
 \pm 500 Hz

4. When completing the measurements, restore the original conditions.

What kind of signal is a transmission signal?

It is a modulated signal with a currently-set Tx output power. By default, a non-modulated signal with a Tx output power of 2 W is defined.

- - Tx output power: 2 W fixed
- - Modulated signal: For details of the modulated signal defined in the [TX Test] screen from the [For Service] menu, refer to page 7-7.

7.3 Tx Output Power Adjustment

Note:

After the antenna is connected, if a Tx output power measurement does not meet the standard, replace the antenna with a dummy with a resistance of 50Ω to check whether the antenna is OK.

7.3.1 Tx Output Power Adjustment

This adjustment is made by using R24 on the MAIN & TX board. It is made under Tx power output of 2 W. There is no adjustment point for 1 W output separately.

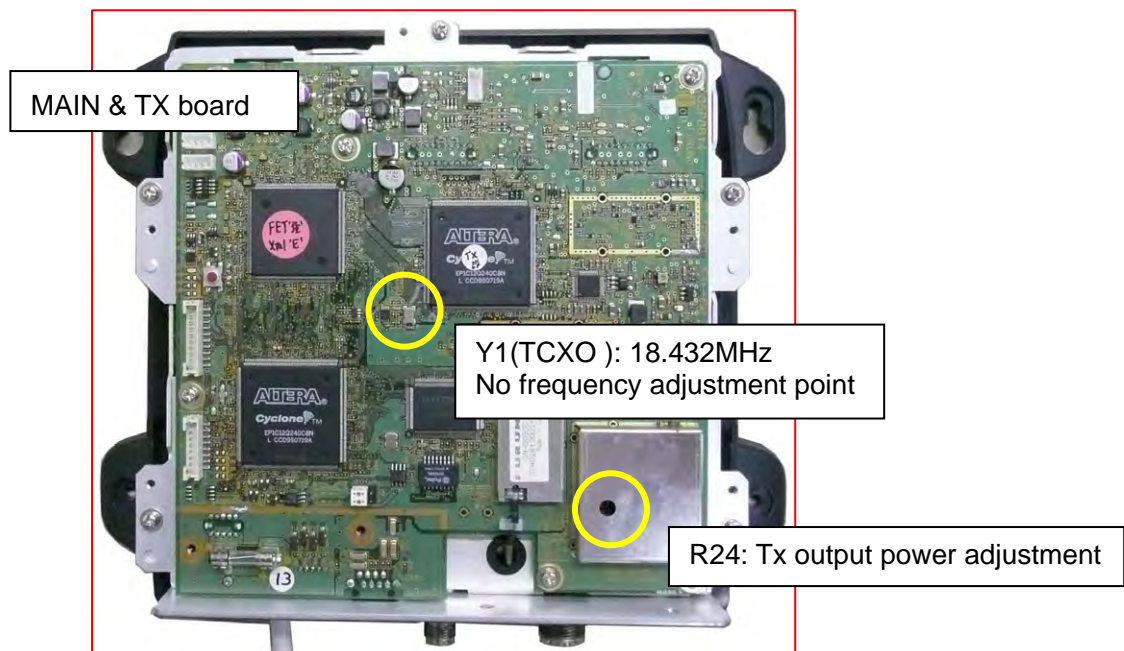

Figure 7.3.1 Output Power Adjustment Point on MAIN Board

7.3.2 Tx Frequency Adjustment

Implementation of Y1(TCXO) requires no adjustment.

If a deviation of ± 500 Hz or greater is found, the MAIN & TX board must be replaced.

Y1 (TCXO): 18.432 MHz is a reference clock frequency of the MAIN & TX board.

Tips: What are the meanings of individual modulated signals?

From the [For Service] menu, select [Device Test] and press the [Select] button; then open the pull-down menu where a list of modulated signals is displayed.

When measuring a Tx output power or a frequency, select a “Modulated signal” among the signals from “Carrier” to “PRS” which are transmitted continuously in the table below.

The AIS test signals: burst signals (one Packet: 26.6msec) from “Test2” cannot be used to measure the Tx output power on the power meter.

Table 7.3.1 Description of Modulated Signals

Modulated signal	Description
Carrier	Non-modulated signal, continuously transmitted (for 15 seconds)
10101	Modulated signal, a series of “1010101” continuously transmitted (for 15 seconds)
110011	Modulated signal, a series of “110011” continuously transmitted (for 15 seconds)
1111	Modulated signal, a series of “1111” continuously transmitted (for 15 seconds)
PRS	Modulated signal, a series of “Random” continuously transmitted (for 15 seconds)PRS: Pseudo Random Sequence
Test2[33%] Training: 0101 Data: 01010101	Duty 33% : 1 fram // 2250 x 33% = 742 packets Training: 0101: 24 bit, Data is transmitted by “01010101: 168bits”.
Test2[50%]	Duty 50% : 1 fram // 2250 x 50% = 1125 packets Training: 24 bits consisting of a pattern of “0101”, Data is transmitted by “01010101: 168 bits”.
Test2[100%]	Duty 100% : 1 fram // 2250 x 100% = 2250 packets Training: 24 bits consisting of a pattern of “0101”, Data is transmitted by “01010101: 168 bits”.
Test2[33%] Training: 0101 Data: 00001111	Duty 33% : 1 fram // 2250 x 33% = 742 packets Training: 24 bits consisting of a pattern of “0101”, Data is transmitted by “00001111: 168 bits”.
Test3[50%]	Duty 50% : 1 fram // 2250 x 50% = 1125 packets Training: 24 bits consisting of a pattern of “0101”, Data is transmitted by “00001111: 168 bits”.
Test3[100%]	Duty 100% : 1 fram // 2250 x 100% = 2250 packets Training: 24 bits consisting of a pattern of “0101”, Data is transmitted by “00001111: 168 bits”.
Test4[33%] Training: 0101 Data: PRS	Duty 33% : 1 fram // 2250 x 33% = 742 packets Training: 24 bits consisting of a pattern of “0101”, Data is transmitted by “Random: : 168 bits”.
Test4[50%]	Duty 50% : 1 fram // 2250 x 55% = 1125 packets Training: 24 bits consisting of a pattern of “0101”, Data is transmitted by “Random: : 168 bits”.
Test4[100%]	Duty 100% : 1 fram // 2250 x 100% = 2250 packets Training: 24 bits consisting of a pattern of “0101”, Data is transmitted by “Random: : 168 bits”.

Test5 Training: 22Bit	Duty 33% Training: 22 bits, Rampup: 8 bits
Message18 A-Bch 1sec Rate (For Emission)	Message 18 is transmitted by switching between A and B channels every second.
Test2+1Bit(For Ramp)	At the end of the data of Test2, 1bit (1) is added.

Chapter 8. Maintenance

This chapter describes the details of various menus including “For Service”, “Alarm Status”, “Sensor Status”, “Tests”, and “(Silent)”.

8.1 For Service

As a service menu, the [For Service] menu is provided to recall this menu, a password is required. For details of password, see Furuno Information: FQ4-2008-014. The Login Name and Password required in this menu differ from those to go through Initial Setup -> Ship Static Edit.

Recall the [For Service] menu

1. Start Internet Explorer and enter “http://172.31.24.3” in the URL field to open the Web browser screen of FA-50, where click the [For Service] button.

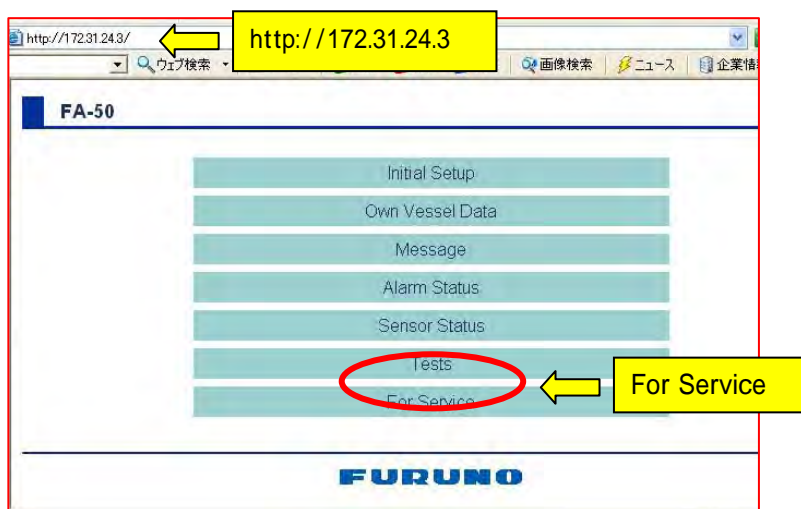

2. To proceed to the [For Service] menu, type in "xxxxxx" in the Password field and click the [Login] button. This Password is same as that of GMDSS equipment such as FS-2570.

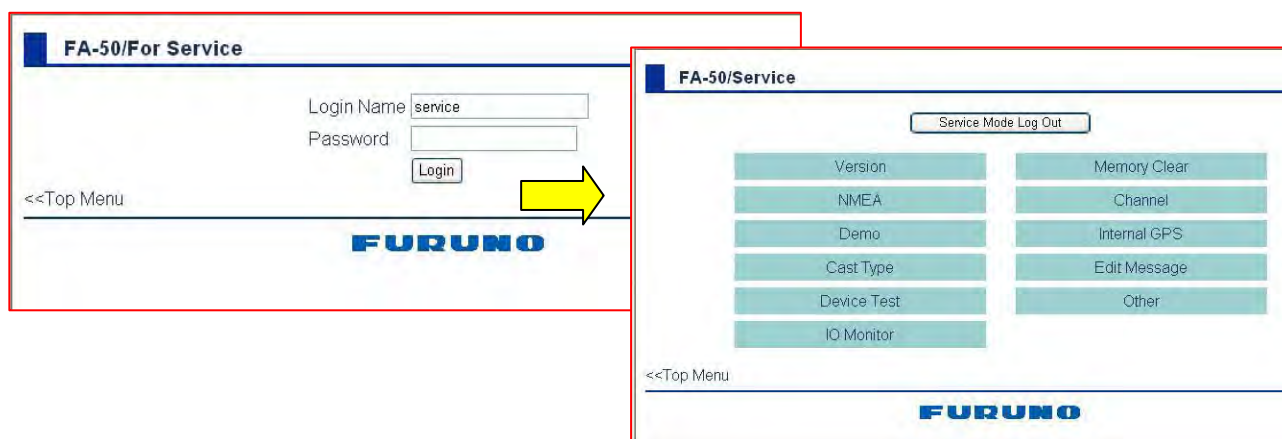

8.1.1 Version

In this screen, program version can be checked.



Table 8.1.1 Version Display

Item	Display Example	Description
Version	0550233-01.0x	Displays a version of the FA-50 program.
CPU 1	X1.105B1.14 200806061154	Displays an exact version of MAIN CPU (U15) and a creation date in a format of "yyyymmddhhmm". Where X indicates an application and B does a version of the boot program.
CPU 2	Y2.27 3ch 20080351756	Displays an exact version of CPU 2(SH4: U31) and a creation date in a format of "yyyymmddhhmm". Y indicates a version of the application program.
FPGA	01.11 20071123	Displays an exact version of FPGA 2(U38/15) and a creation date in a format of "yyyymmdd".

8.1.2 NMEA

In this menu, settings of VDM output, VDO output, checksum, and alarm can be made.

FA-50/Service/NMEA

Output VDM	ClassB	(default=ClassB)
Output VDO	ClassB	(default=ClassB)
Sentence without checksum	Don't use	(default=Don't use)
EPFS Alarm	Off	(default=Off)
L/L, SOG, COG Alarm	Off	(default=Off)
HDG Alarm	Off	(default=Off)
External GNSS	Use	(default=Use)

<<Service Menu

FURUNO

Table 8.1.2 NMEA Menu Items

Setting Item		Remarks
Output VDM	Class A	Select a type of output message of VDM. Normally, Class B should be specified.
	Class B	
	All Message	
Output VDO	Class A	Select a type of output message of Null VDO. Normally, Class B should be specified.
	Class B	
	A+B	
Sentence without checksum	Use	Determines whether to accept a sentence at the external GPS depending on the presence or absence of a checksum.
	Don't use	
EPFS Alarm	Off	Determines whether to output an alarm when reception at the external EPFS is disabled.
	On	
L/L, SOG, COG Alarm	Off	Determines whether to output an alarm when reception at the internal (external) GPS: L/L, SOG, COG is disabled.
	On	
HDG Alarm	Off	Determines whether to output an alarm when reception at the external HDG is disabled.
	On	
External GNSS	Use	Determines whether to use the external GPS.
	Don't use	

Example of Alarm Status on the Web browser Screen

Note:

When no alarm occurs, “Nothing Data” is displayed.

Type	UTC	Description
EPFS		External EPFS Lost
L/L		No Sensor Position in Use
SOG		No Valid SOG Information
COG		No Valid COG Information
HDT		No Valid HDT Information

<<Top Menu

FURUNO

1. Output VDM

VDM (VHF Data Link Message) is a message received from other ships or VTS. According to the settings as described below, a message type of the received VDM message is specified to be outputted to the COM port and LAN port.

- Class A
AIS messages of MSG. 1 to 63 are outputted. Where the messages reporting to other ships are omitted.
- Class B
AIS messages of MSG. 1 to 24 are outputted. Where the messages reporting to other ships are omitted.
- All Message
All AIS messages of MSG. 0 to 63 are outputted. Where the messages reporting to other ships are included.

Tips:

As a number to express a type of message such as MSG. 1 or 2, 6 binary digits can be used.

Therefore, numbers from 0 to 63 can be used to identify individual types of messages. As of now, different types of messages including MSG. 1 to 24 are defined. MSG. 0 and MSG. 25 through 63 are not yet defined. For details of the message types, refer to Appendix 3.

2. Output VOD

NULL VDO (VHF Data Link Own-vessel Message) is an own vessel data including dynamic and static information that is not used for VHF transmission. According to the settings as described below, a message format used to output the received message is determined. On the AIS display device, information contained in the received message is displayed in the specified format. In other words, this setting is used to convert a message format to what is acceptable by the display device to produce an output. The message is outputted to the COM port and LAN port.

- Class A
The NULL VDO output is produced using MSG. 1(Position Report), 5(Static and Voyage Related message).
- Class B
The NULL VDO output is produced using MSG. 18(Standard Class B Equipment Position), MSG. 24(Class B Static data).
- Class A+B
The NULL VDO output is produced using MSG. 1, 5, 18, and 24.

3. Sentence without checksum

According to the settings as described below, whether or not to retrieve the data in a sentence from the external GPS is determined depending on the presence or absence of checksum attached to the sentence.

In IEC62287 standard, the external GPS data must use sentences including Check Sum and/or Mode Indicator.

- Use
Sentences without checksum are also retrieved.
- Don't use
Sentences without checksum are not retrieved.
For a sentence with checksum, its checksum is checked and, if an error is found, it is not retrieved.

4. EPFS Alarm

When a position data from the external GPS is lost or invalid, whether or not to issue the “External EPFS lost” alarm is determined. No connection to the external GPS should designate a setting of “Off”.

The position data sentences, including GNS, GGA, RMC, and GLL, are individually given a different priority depending on the presence or absence of the positioning mode. Priority of the relating sentences is described below:

GNS > GLL (with the Mode indicator) > GGA > RMC (with the Mode indicator) > GLL (without the Mode indicator) > RMC (without the Mode indicator)

5. L/L, SOG, COG Alarm

When L/L (position data), SOG (Speed over ground), or COG (Course over ground) data from the built-in (external) GPS ^{Note} is lost or invalid, whether or not to issue either alarms below is determined.

Note:

If the built-in GPS does not determine positions, no external GPS data is used.

Therefore, this alarm means an error on the built-in GPS.

- L/L: no sensor position in use
- SOG: no valid SOG information - COG: no valid COG information

When determining the validity of L/L, SOG, or COG data, it takes 30 seconds to determine that it is valid, while 5 seconds invalid. Priority of the relating sentences is described below:

- L/L: GNS > GLL (with the Mode indicator) > GGA > RMC (with the Mode indicator) > GLL (without the Mode indicator) > RMC (without the Mode indicator)
- SOG, COG: VBW > RMC > VTG > OSD

Note:

VBW becomes valid only when HDG data is valid.

6. HDG Alarm

When an HDG data is lost or invalid, whether or not to issue the HDG alarm (Heading lost/invalid) is determined. No connection to the HDG data should designate a setting of “Off”.

The data becomes valid at the time of input start, while 5 seconds passes until it becomes invalid.

Priority of the relating sentences is described below:

- HDT > OSD

7. External GNNS

This setting is used to determine whether or not to use a position data from the external GPS. No connection to the external GPS should require a setting of “Don’t use”.

For AIS in Class B, the External GNNS data is not mandatory.

The position data sentences of GNS, GGA, RMC, and GLL are acceptable. Priority of these sentences is same as described in “4. EPFS Alarm” on page 8-6. Priority of GNSS to be retrieved is described below:

external DGPS > built-in DGPS > external GPS > built-in GPS

Note:

If the built-in GPS does not determine positions, no external GPS data is used.

- Use
Determines that the external GPS is used.
- Don’t use
Determines that no external GPS is used.

Tips: Requirements when data from the external GPS is used

- 1) The datum of the external GPS should be WGS84, where the DTM sentence is outputted and the coordinates of WGS-84 are determined.
- 2) A valid RAIM sentence (GBS) should be received and expected deviations of the latitude and longitude should be less than 10 m.
- 3) The external GPS-determined position should be within 26 m of the built-in GPS-determined position.
- 4) The data format complies with IEC61162-1 including Mode Indicator and Check Sum.

8.1.3 Demo

In this menu, reception of the actual VHF link is ignored in the simulator mode and the system operates as if it receives the AIS signal recorded in Tokyo Bay and Osaka Bay. The simulated AIS targets of Class A including 9 ships in the Tokyo Bay area and 5 ships in the Osaka Bay area are displayed. Similar to the normal operation, the scenario-based data, including VDM and VDO sentences, is outputted to the external equipment.

The external or built-in GPS data and/or heading data are not required. The own ship's static data and navigation data including MMSI, IMO NO, and ANT POS are specified with the predefined values. The position data is used to create the same situation as when they were entered externally.

The Demo mode remains active even when powering off.

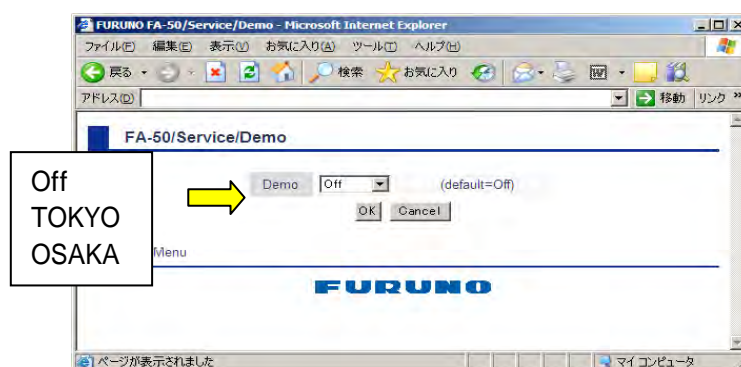

Table 8.1.3 Own Ship's Data in DEMO Mode

Own Dynamic Data	1: Tokyo Bay	2: Osaka Bay
DATE	Current date/time	Current date/time
LAT	35° 12.410'N	34° 31.000'N
LON	139° 43.458'E	135° 04.000E
SOG	0.0kt	8.0kt
COG	270.0°	90°
ROT	0.0° /min	0.0° /min
HDG	270.0°	90°
PA	H	H
GPS	EXT DGPS	EXT DGPS
RAIM	UNUSE	UNUSE

Table 8.1.4 Other Ship's Data in DEMO Mode

Target Name	MMSI	1: Tokyo Bay		2: Osaka Bay	
		Initial value of Pos.	SOG	Initial value of Pos.	SOG
DEM0	999999000	35° 05.146N 139° 38.996E	15, 12, 8, 5, 4kt variable	34° 30.000N 135° 16.000E	8.0kt
DEM1	999999001	35° 24.319N 139° 40.447E	28, 8, 10, 12, 8, 3, 6, 8 kt variable	34° 34.567N 135° 04.000E	8.0kt
DEM2	999999002	35° 00.948N 139° 48.116E	6, 5, 7, 8, 6, 4 kt variable	34° 29.567N 135° 04.000E	16.0kt
DEM3	999999003	35° 10.408N 139° 47.138E	12, 10, 1, 3, 7, 8 kt variable	34° 34.567N 135° 10.110E	12.0kt
DEM4	999999004	35° 47.279N 139° 40.195E	16, 12, 10, 8, 5 kt variable	34° 32.621N 135° 07.1790E	0.0kt
DEM5	999999005	35° 08.593N 139° 46.916E	15, 12, 8, 5, 4, 15 kt variable		
DEM6	999999006	35° 12.755N 139° 47.076E	12, 8, 5, 4, 15 kt variable		
DEM7	999999007	35° 14.497N 139° 46.398E	8, 7, 6, 5, 2, 4, 5 kt variable		
DEM8	999999008	35° 10.747N 139° 46.546E	7, 6, 5, 2, 4, 5, 8 kt variable		

8.1.4 Cast Type

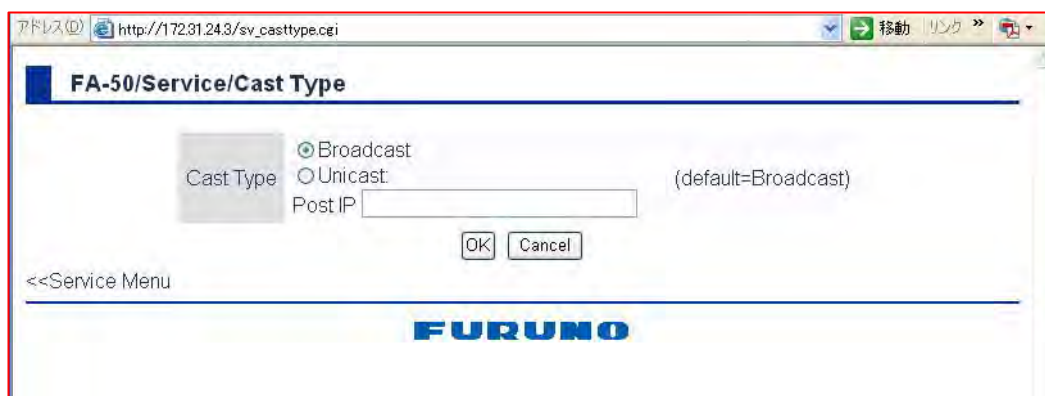

1. Broadcast

Normally, Broadcast should be specified.

Within the same network or all networks, AIS data is transmitted directing to any number of targets.

2. Unicast

Designating one address in the same network, AIS data is transmitted to this particular target.

When designating an address in a different network, select Initial Setup -> Network Setup, and specify "Gateway Address" with the IP address of the Router.

- IE URL => FA-50 IP Address

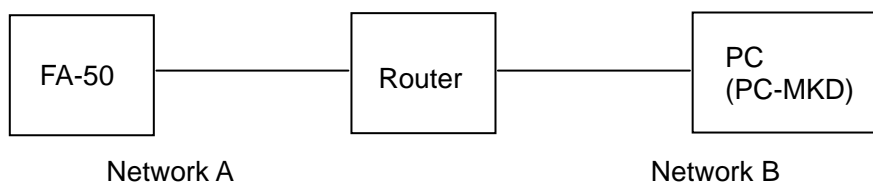

- Network Setup -> Gateway Address => Router IP Address
- Unicast -> Post IP => PC IP Address

8.1.5 Device Test

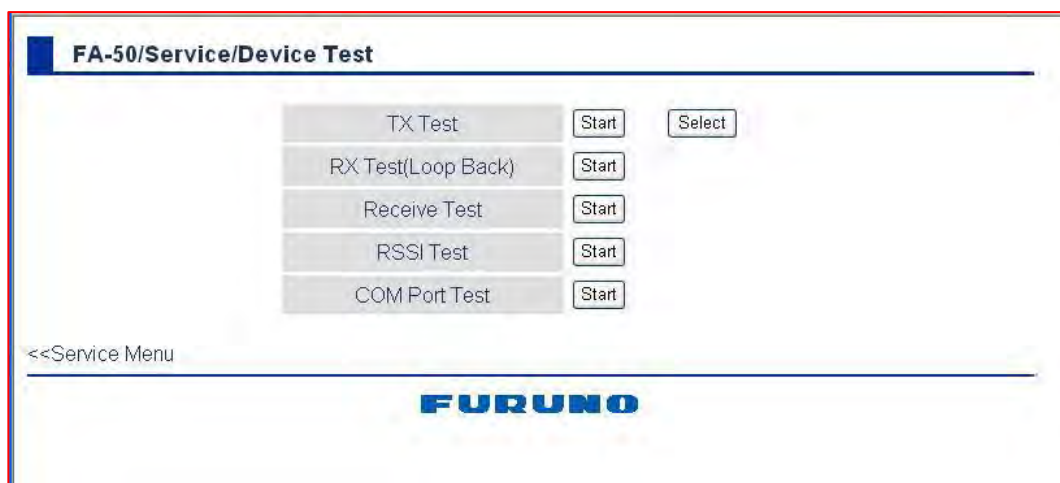

1. TX Test

Refer to “Chapter 7. Measurement”.

In the TX Test menu, select a modulated signal and control a transmission start operation.

The signal selected in this menu is modulated on the channel specified in the Channel menu.

2. Rx Test (Loop Back)

In this menu, the Tx PA circuit is turned OFF to detect a leakage of signal on the RX1 and RX2 boards.

More specifically, when a certain message has been transmitted 10 times and if the message can be received 5 times, it is judged as OK.

The signal level is tested using a signal ranging from -60 to -70dBm in terms of SSG. For example, if RX1 “NG” is shown, a failure occurs on the RX1 board.

3. Receive Test



In this menu, the reception status on the RX1 and RX2 boards can be checked.

- Received stations:

It indicates a total number of Class A and B stations currently active in receiving.

- RX1 Received packets (per 1min):

It indicates the number of packets from the Class A and B stations received within 1 minute on the RX1 board.

- RX2 Received packets (per 1min)

It indicates the number of packets from the Class A and B stations received within 1 minute on the RX2 board.

Note:

Packet transmission is affected by the ship speed. In the Regional operating areas, the Tx channel also varies.

4. RSSI Test

In this screen, signal strengths of the received signals corresponding to 10 packets synchronized to UTC are displayed. The RX1/SS column contains data of the signals received on the RX1 board, while the RX2/SS column on the RX2 board. Click [Refresh] to update the data.

The screenshot displays the 'FA-50/Service/RSSI Test' menu. It features a table with the following data:

	RX1/SS	RX2/SS
	2	1
	2	0
	4	0
	1	6
	3	1
	1	1
	2	1
	2	2
	3	0
	0	3

At the top left, there is a 'Refresh' button. At the bottom left, there is a '<<Device Test' button, and the 'FURUNO' logo is centered at the bottom.

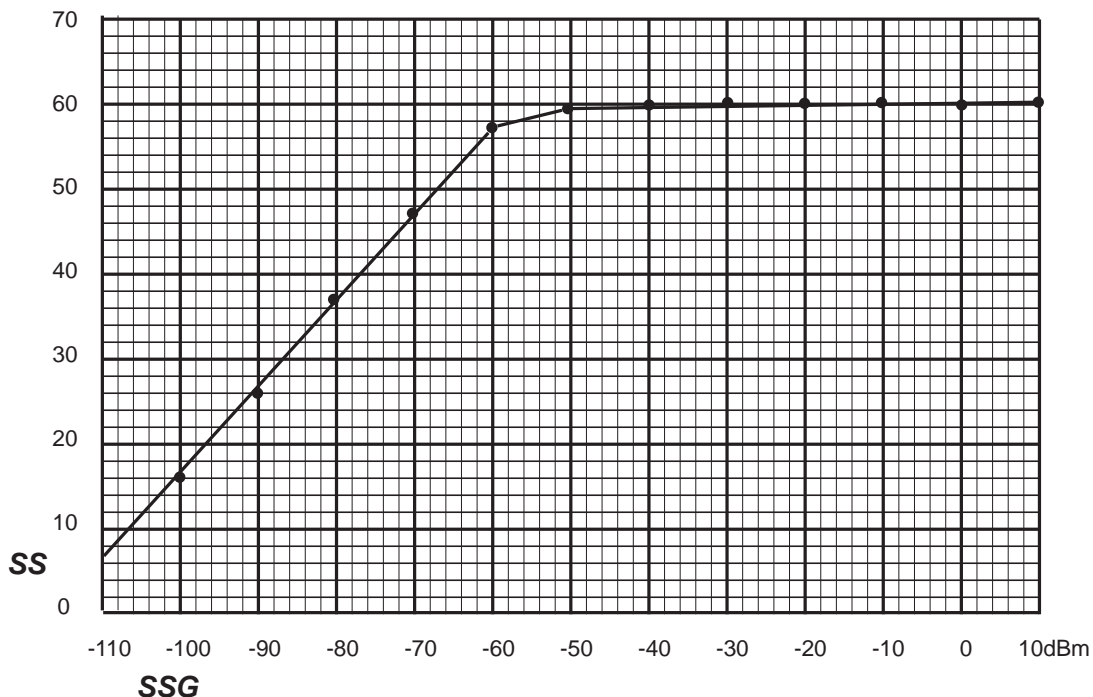
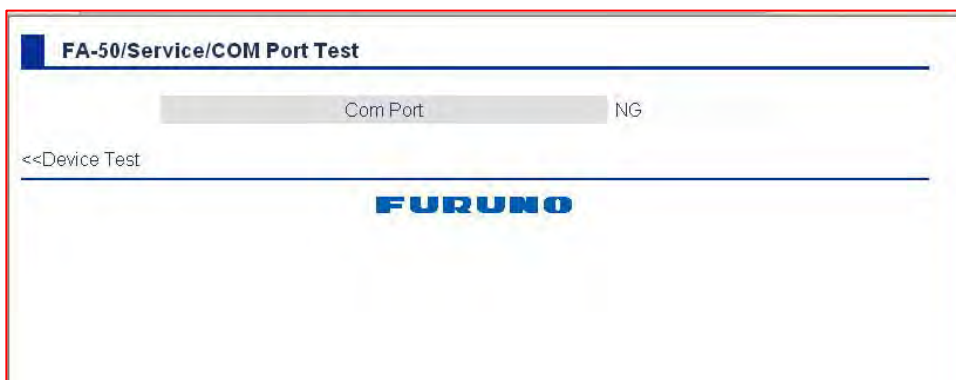

Figure 8.1.1 SS vs. SSG Input Characteristic

5. COM Port Test

In this screen, a result of the Loop back test on the COM port is indicated by OK/NG. Before starting the test, make a jumper connection between TX and RX data in the COM port.

- Between White (TD-A) and Yellow (RD-H)
- Between Blue (TD-B) and Green (RD-C)



8.1.6 IO Monitor

In this screen, reception data at the selected port is monitored. Click [Refresh] to update the data.

- COM : Monitoring input signals on the serial port
- NavNet : Monitoring input signals on the LAN port number: 10021
- PCMKD : Monitoring input signals on the LAN port number: 10033
- GPS : Monitoring reception data on the built-in GPS

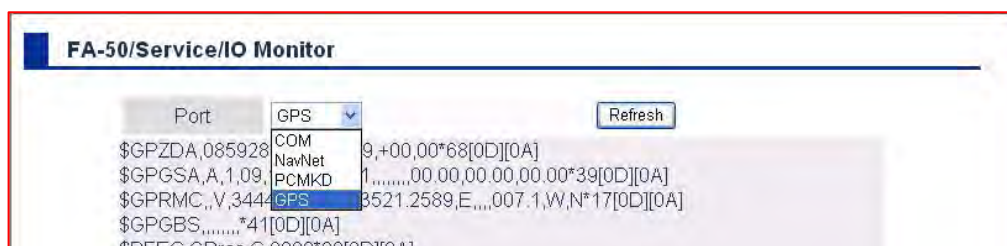

Example of IO Monitor Display

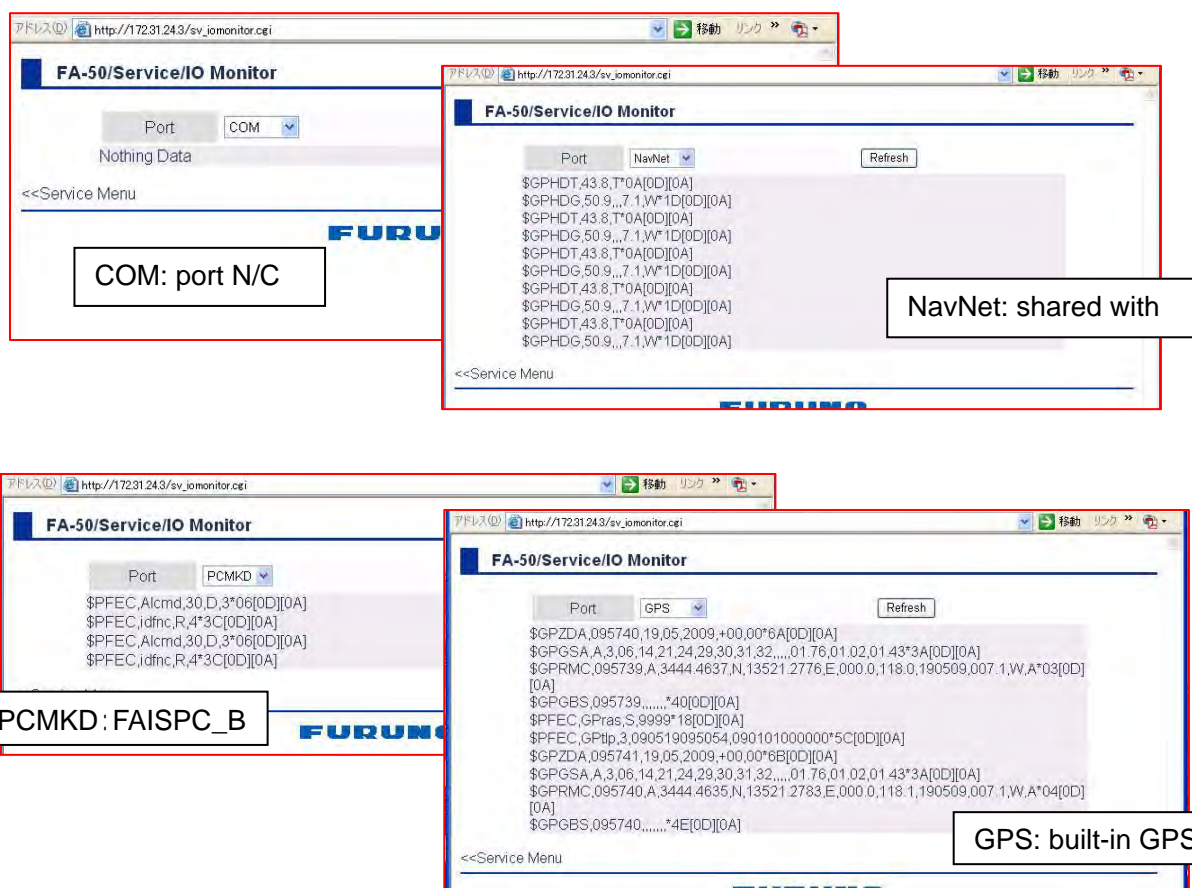

8.1.7 Memory Clear

Executing Memory Clear automatically reboots the FA-50.

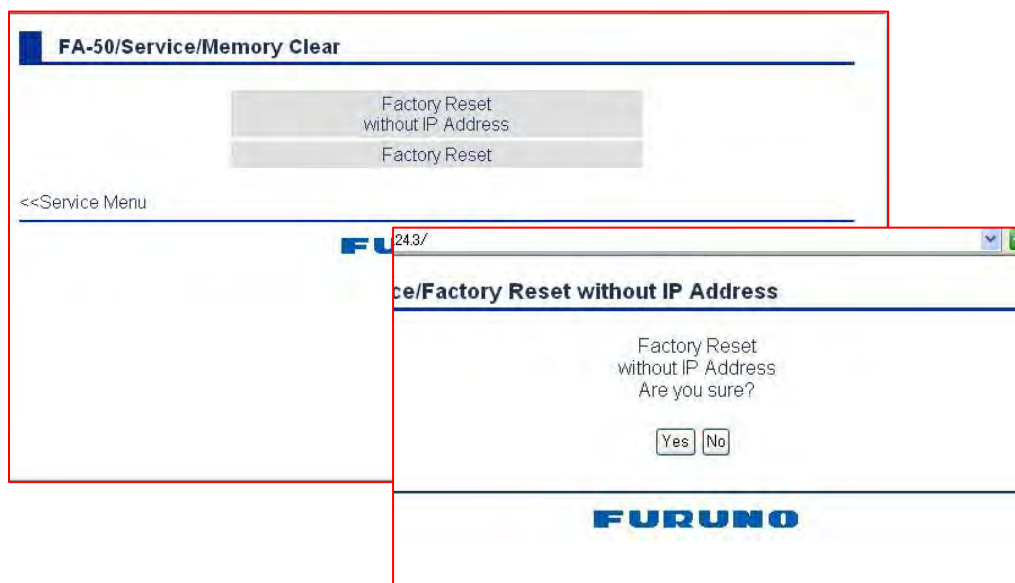

1. Factory Rest without IP Address

The settings in [Initial Setup], except those in [Network Setup], are cleared.

2. Factory Reset

All of the set values are cleared and restored to the factory defaults.

Tip:

Memory clear can be also executed by setting a DIP switch: S4 on the MAIN & TX board. Refer to Page 8-27.

8.1.8 Channel

In this screen, Channel and Operation mode can be set manually. To do a manual setting, the setting of “Channel Selection” should be switched from “Auto” to “Manual”. When conducting frequency measurement or Tx power measurement, the “Manual” setting is effective.

FA-50/Service/Channel

RX1	2087	(default=2087)
RX2	2088	(default=2088)
TRX Mode	TX A+B/RX A+B	(default=TX A+B/RX A+B)
TX Power	2w	(default=2w)
Channel Selection	Auto	(default=Auto)
DSC Time Sharing	On	(default=On)

When setting channels manually, confirm that channels are usable in current region, AIS information cannot be received in the regions where selected channel is not available.

OK Cancel

<<Service Menu

FURUNO

1. RX1

The channel data specified in this field is reflected on the RX1 board.

At a measurement of Tx power, by selecting Device Test -> TX Test, a transmission is performed over the channel set in the RX1 field and by the Tx output power set in the Tx Power field.

By default, the international AIS channel number of “2087” is set.

When Channel Selection is set to Auto, the channel changes according to a command issued from the Regional operating areas. When Manual, the specified channel is effective in operation.

The channel in operation is displayed in View Channel of Own Vessel Data.

2. RX2

The channel data specified in this field is reflected on the RX2 board.

By default, the international AIS channel number of “2088” is set.

When Channel Selection is set to Auto, the channel changes according to a command issued from the Regional operating areas. When Manual, the specified channel is effective in operation.

The channel in operation is displayed in View Channel of Own Vessel Data.

3. TRX Mode

This field is effective when Channel Selection is set to “Manual” in the mode setting. When Channel Selection is set to “Auto”, the Operation mode changes according to a command issued from the Regional operating areas. When Manual, the specified mode is effective in operation.

The mode in operation is displayed in View Channel.

Note:

RX1 differs from RXA, while RX2 differs from RXB. In the Regional operating areas, Rx1 could be RxB, while Rx2 could be RxA.

4. TX Power:2W/1W/0W

This field is effective when Channel Selection is set to “Manual” in the Tx power setting.

When Channel Selection is set to “Auto”, the Operation mode changes according to a command issued from the Regional operating areas. When Manual, the specified mode is effective in operation. The mode in operation is displayed in View Channel.

At a measurement of Tx power, by selecting Device Test -> TX Test, a transmission is performed over the channel set in the RX1 field and by the Tx output power set in this field.

5. Channel Selection: Auto/Manual

When conducting a Manual operation of RX1, RX2, TRX Mode, or TX Power, this field should be set to “Manual”. The “Manual” setting has a higher priority than “Auto”. For example, it is used when performing a measurement of Tx power or frequency deviation. If the area data has not been stored for some reason, the area data cannot be received over the international AIS channel. In this case, the “Manual” mode is set once to select the current channel used in the Regional operating areas to retrieve the area data and then the “Auto” mode is reset.

6. DSC Time Sharing

Class B-AIS, like Class A-AIS, can receive DSC signals.

For Class B-AIS, a receive method is defined, where a dedicated DSC receiver or AIS receiver is used to receive AIS and DSC signals by a time sharing technique.

FA-50 is not equipped with a DSC (CH70)-specific receiver; therefore, by switching either RX1 or RX2 boards for AIS signal reception to DSC reception, both AIS and DSC signals can be received using a time sharing technique.

DSC messages that can be received include VTS messages directing to individuals and all vessels as well as Distress alert messages.

- on : DSC signals are received.

(By sharing the RX board, both AIS and DSC receptions are carried out.)

- off: No DSC signal is received. (The RX board is specifically for AIS reception.)

Note:

When a Distress alert is received, the position data of the distressed ship is sent by PFEC sentence to PC-MKD (Japanese Spc.: FAISPC_B). No output is produced on NAVNET 3 device or Radar.

Table 8.1.5 Time Period of DSC Signal Reception

Board for Reception	DSC Signal Monitoring Time (each hour)	Board for Reception	DSC Signal Monitoring Time (each hour)
RX1(2)	5:30 ~ 5:59	RX1(2)	35:30 ~ 35:59
RX2(1)	6:30 ~ 6:59	RX2(1)	36:30 ~ 36:59
RX1(2)	20:30 ~ 20:59	RX1(2)	50:30 ~ 50:59
RX2(1)	21:30 ~ 21:59	RX2(1)	51:30 ~ 51:59

Tips: AIS Tx operations during DSC monitoring

1. During DSC signal monitoring, if any DSC message has not been received, an AIS message can be sent.
2. While transmitting an AIS message, a DSC message cannot be received.
3. During DSC receiving, an AIS message cannot be sent.
4. When a request for a slot-designated transmission (FATDMA transmission) by MSG. 15 is received from VTS, the transmission should be carried out despite during DSC receiving. Accordingly, DSC messages cannot be received at that time.
5. When MSG. 22 or a DSC management message requests that the AIS operation channel should be specified with CH70, 1070, 2070, 1470, and 2470, this channel is considered as an abnormal channel and the reception mode over the international channel is activated (RXA+B) and the AIS transmission should be terminated. The transmission will resume when the ship left the designated area.
6. When setting Channel Selection to “Manual” in the Channel set menu
 - When RX1(2) is specified with CH70, both DSC reception and AIS transmission are carried out over CH70.
 - When RX1(2) is specified with CH1070, 2070, 1470, or 2470, AIS transmission/reception are carried out over the designated channel.

8.1.9 Internal GPS

In this screen, positioning conditions of the built-in GPS (GN-8093G) are displayed. The FA-50 can receive the sentences including RMC, GBS, GSA, ZDA, and PFEC from GPS.

If the built-in GPS does not determine positions, reporting does not start.

The screenshot displays the 'Internal GPS' screen with the following data:

Internal GPS	
LAT	34-44.4612',N
LON	135-21.2683',E
SOG / COG	0.0 kt / 96.4 deg
MODE / STATUS	GPS / 3D
RAIM / PA	ON / ON
UTC	28042009 090140

<<Service Menu

FURUNO

8.1.10 Edit Message

In this screen, a message can be edited and sent by executing Message -> Send Message (MSG. 14). For Class B, a message must have been edited before sending.

The screenshot displays the 'Edit Message' screen with the following controls:

Message Select: 1:ANCHOR

Edit Message: ANCHOR

OK Cancel

<<Service Menu

FURUNO

In [Message Select], select a number of the message to be edited and edit it in [Edit Message]. A message can contain 16 characters at maximum. The following messages have been edited. These messages can be edited again.

- | | | |
|-------------------|-----------------|-------------------|
| 1. ANCHOR | 2. AGROUND | 3. MAN OVER BOARD |
| 4. STARBOARD SIDE | 5. PORT SIDE | |
| 6. MAYDAY | 7-10. undefined | |

8.1.11 Other

1. Silent Mode

In this mode, a Tx operation is completely prohibited and the FA-50 operates as a reception-only unit.

In the “Channel” screen, the set value of 2/1/0 W in [Tx Power] is used to control APC in the PA circuit.

To be able to enter the Silent Mode, set [Silent Mode] to “On” to add an item of [Silent] to the Top page of the Web browser screen. By selecting this item, either “Normal” or “Rx Only” can be specified.

Entering the Silent Mode, the mode indication of FAISPC_B switches to “Reception Mode”.

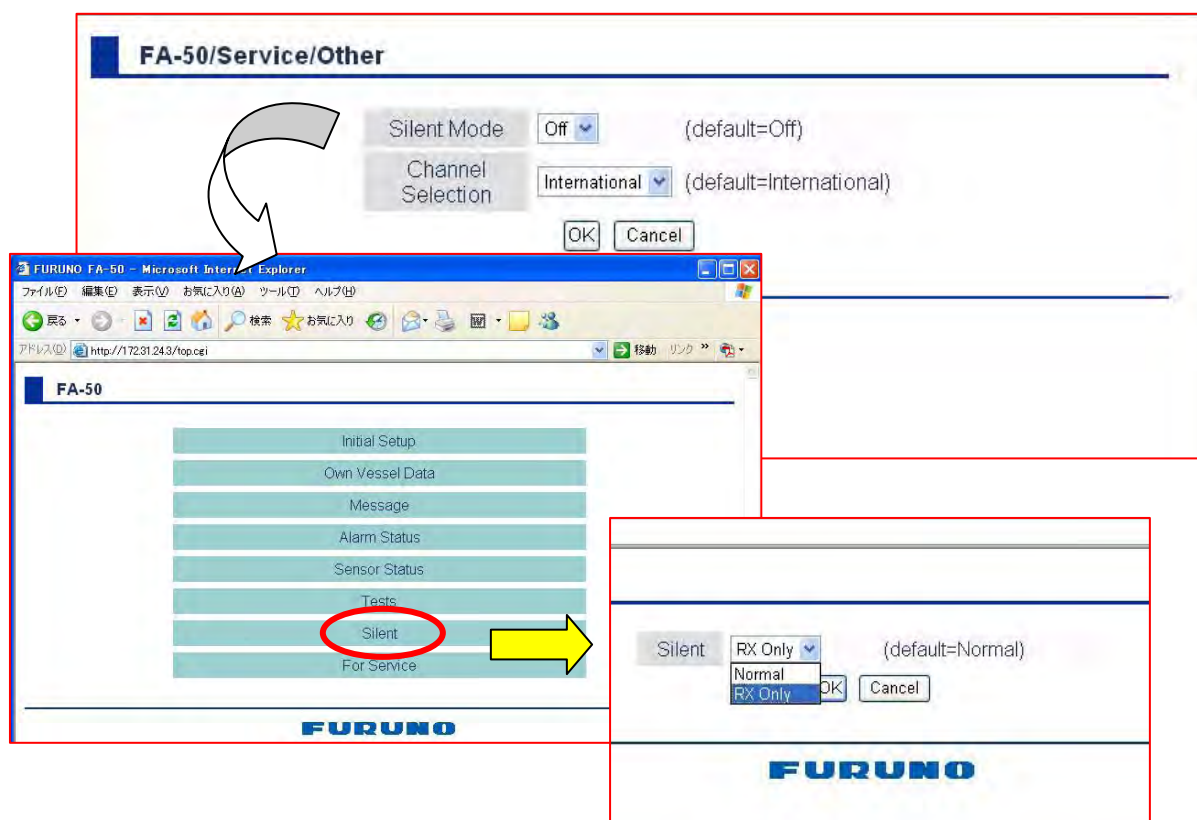

2. Channel Selection

This field is used to switch a Channel between International and USA. For several lists of channels, refer to Appendix 2.

8.2 Alarm Status

In this screen, alarms currently raised are shown. When an event of the alarm terminates, the corresponding alarm display automatically disappears.

The errors shown on the screen are TX, RX1, RX2, EPFS, L/L, SOG COG, and HDG. The alarm outputs of COG, EPFS, HDG, L/L, and SOG, however, can be set to be either displayed or not displayed by setting ON/OFF in the NMEA menu accessed from For Service. For details, refer to page 8-3.

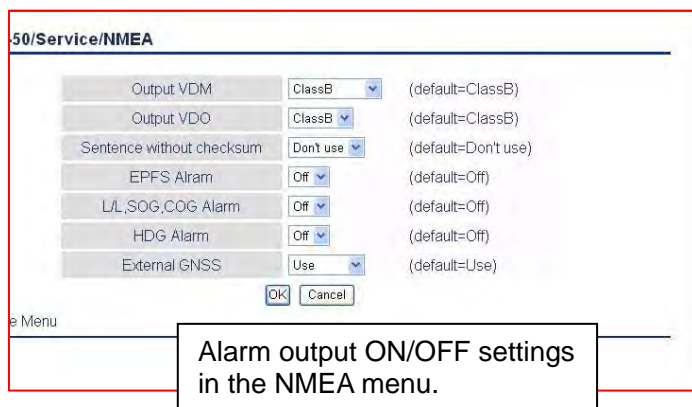

Table 8.2.1 List of Alarm Status Outputs by Model

Error Display	Description	FA-100 FA-150	FA-30	FA-50	
TX	Tx malfunction	Transmission failure, transmission disabled	Yes	No	Yes
ANT	Antenna VSWR exceeds limit	Antenna VSWR failure. Continued operation is allowed.	Yes	No	No
CH1	Rx channel 1 malfunction	RX1 board failure. Transmission is suspended over the relating Tx channel.	Yes	Yes	Yes
CH2	Rx channel 2 malfunction	RX2 board failure. Transmission is suspended over the relating Tx channel.	Yes	Yes	Yes
CH70	Rx channel 70 malfunction	DSC RX board failure. Continued operation is allowed.	Yes	No	No
MKD	MKD connection lost (Minimum Keyboard and Display)	MKD connection is lost. Continuous operation is allowed. (The actual display is different from this.)	Yes	No	No
EPFS	External EPFS lost	Data from the external navigator is lost. Continuous operation is allowed.	Yes	No	Yes/No
L/L	No sensor position in use	No position data is available.	Yes	No	Yes/No
SOG	No valid SOG information (SOG:Speed Over Ground)	Invalid SOG data	Yes	No	Yes/No
COG	No valid COG information (COG:Course Over Ground)	Invalid COG data	Yes	No	Yes/No
HDG	Heading lost/invalid	HDG data is lost/invalid.	Yes	No	Yes/No
ROT	No valid ROT information (ROT:Rate of Turn)	No HDG data nor \$TI-ROT data	Yes	No	No
FAIL		System failures in general	Yes	No	Yes

1. TX (Tx malfunction)

It is displayed when no Tx output is detected in spite of CPU performing a transmission operation, or when a Tx output is detected in spite of CPU not performing a transmission operation. When this error is detected, a failure occurs on the MAIN&TX board.

2. CH1 (Rx channel 1 malfunction)

A signal of “PLL Unlock/Lock” in the PLL circuit on the RX1 board is checked. When this signal is detected, the transmission over the relating channel is suspended. It is possible that a failure occurs on the RX1 board.

3. CH2 (Rx channel 2 malfunction)

A signal of “PLL Unlock/Lock” in the PLL circuit on the RX2 board is checked. When this signal is detected, the transmission over the relating channel is suspended. It is possible that a failure occurs on the RX2 board.

4. EPFS (External EPFS lost)

It is displayed when no position data is inputted from the external GPS, when data input is suspended for 5 seconds or longer, or when Invalid data is detected. The input sentences relating to position data include GNS, GLL, GGA, and RMC.

5. L/L (No sensor position in use)

It is displayed when no position data is inputted from both internal and external GPS devices, or when Invalid data is detected on both inputs. The input sentences relating to position data entered from the external device include GNS, GLL, GGA, and RMC.

6. SOG (No valid SOG information)

It is displayed when no SOG data is inputted from both internal and external GPS devices, or when Invalid data is detected on both inputs. The sentences relating to SOG include VBW, RMC, VTG, and OSD.

7. COG (No valid COG information)

It is displayed when no COG data is inputted from both internal and external GPS devices, or when Invalid data is detected on both inputs. The sentences relating to COG include VBW, RMC, VTG, and OSD. Where VBW is used only when HDT is effective.

8. HDG (Heading lost/invalid)

It is displayed when no heading data is found or when the data is Invalid. The sentences relating to heading include HDT(HC invalid) and OSD. Where VBW is used only when HDT is effective.

8.3 Sensor Status

The status of sensors currently used is displayed.



Table 8.3.1 Details of Sensor Status

Status Display	Description
UTC Clock Lost	UTC is lost.
External DGPS in Use	External DGPS is in use.
Internal DGPS in Use	Internal DGPS is in use.
External GPS in Use	External GPS is in use.
Internal GPS in Use	Internal GPS is in use.
External SOG/COG in Use	External SOG/COG is in use.
Internal SOG/COG in Use	Internal SOG/COG is in use.
Heading Valid	Heading is in use.
Channel Management Parameters Changed	After 60 seconds from receiving an area change command, it disappears.

Table 8.3.2 Sentences used

Data	Sentences
Position	GNS > GLL: (with the Mode indicator) > GGA > RMC (with the Mode indicator) > GLL (without the Mode indicator) > RMC (without the Mode indicator)
SOG /COG	VBW > RMC > VTG > OSD Note: VBW is used only when HDT is effective.
Heading	HDT > OSD

8.4 Tests

In this screen, two options: Transponder Test and GPS Test are displayed.

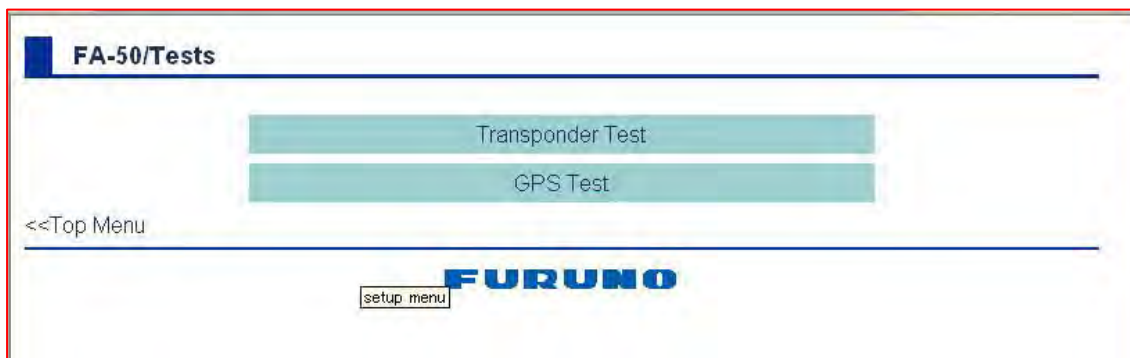

8.4.1 Transponder Test



1. Version

It indicates a program version.

2. CPU1 RAM

It displays a test result of RAM used in the CPU with FPGA built in. This test is performed when the Web browser screen opens and the result is displayed here. If NG, a failure exists on the MAIN&TX board.

3. CPU2 RAM

It displays a test result of RAM used in the SH4 CPU. This test is performed at power on and the result is displayed here. If NG, a failure exists on the MAIN&TX board.

4. ROM

It displays a test result of ROM used in the SH4 CPU. It is continuously checked. If NG, a failure exists on the MAIN&TX board.

5. RX1

It displays a result of checking if PLL Lock/Unlock is detected on the RX1 board. If Lock is detected, it displays OK. If NG, a failure occurs on the RX1 board.

6. RX2

It displays a result of checking if PLL Lock/Unlock is detected on the RX2 board. If Lock is detected, it displays OK. If NG, a failure occurs on the RX2 board.

7. TX

It displays “NG” when no Tx output is detected in spite of transmission performed, or when a Tx output is detected in spite of no transmission performed. If “NG”, a failure occurs on the MAIN&TX board.

8.4.2 GPS Test

Clicking on this button invokes a command for starting a self test toward the built-in GPS receiver (GN-8093G) and the test is started. The test results can be seen on the screen.



1. Version

It indicates a version number of the program installed on the GPS receiver on the MAIN&TX board. If NG is shown, a failure occurs on the GPS receiver (MAIN&TX board).

2. ROM

It displays a test result of ROM in the GPS receiver. Or it indicates “Time Out Error” when serial communication between FPGA and GPS receiver has failed. If NG is shown, a failure occurs on the GPS receiver (MAIN&TX board).

3. RAM

It displays a test result of RAM in the GPS receiver. Or it indicates “Time Out Error” when serial communication between FPGA and GPS receiver has failed.

4. Antenna

This test detects a current flowing through the GPS antenna and check if the current measurement meets the specification value. If out of spec, “NG” is indicated. Or it indicates “Time Out Error” when serial communication between FPGA and GPS receiver has failed.

8.5 DIP Switches and LEDs

8.5.1 DIP Switches

The settings of DIP switches are read in at startup.

Table 8.5.1 Functions of DIP Switches

DPSW					Code	Function
4	3	2	1	Code		
N/A	OFF	OFF	OFF	0	At normal operation	
N/A	OFF	OFF	ON	1	Clear all, except IP address. (Same function as selecting Memory Clear -> Without IP Reset)	
N/A	OFF	ON	OFF	2	Clear IP address and clear DDS offset. (Initial Setup -> Network Setup menu)	
N/A	OFF	ON	ON	3	Clear all and clear DDS offset. (Same function as selecting Memory Clear -> Factory Reset)	
N/A	ON	OFF	OFF	4	MAC rewrite mode (used at a factory)	
N/A	ON	OFF	ON	5	For development debugging	
N/A	ON	ON	OFF	6	Not used	
N/A	ON	ON	ON	7	For development debugging	

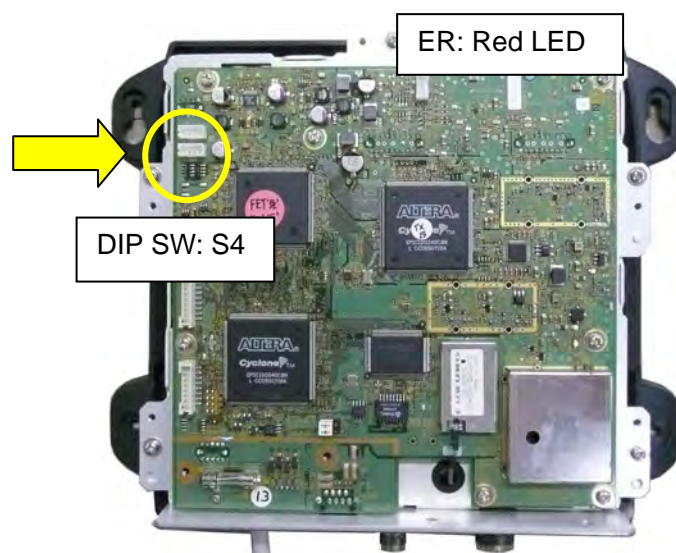

Note:

When powering on with any DIP switches set ON, the ER lamp (red) flashes.

8.5.2 LED

1. Panel LEDs

Table 8.5.2 Functions of Panel LEDs

LED	Color	Function
POWER	Green	Power ON indicator, which lights up at power ON.
ERROR	Red	Error indicator, BITT error (controlled by SH-4) Lights up when an error in ROM/RAM or the transmit circuit is detected.
TX	Blue or Yellow	Blue: Data transmission indicator, which lights up for 1 sec or longer at AIS transmission (controlled by FPGA_2)
		Yellow: blinking at TX Time out (transmission error indicator), flashes in a cycle of 200 msec when transmission fails 2 or more times in a row. Lights up in orange when an unregistered MMSI detected.
RX	Yellow	Data receipt indicator, which lights up for 50 msec at AIS reception (controlled by FPGA_2)

((PWR)) (ER) ((TX)) ((RX))

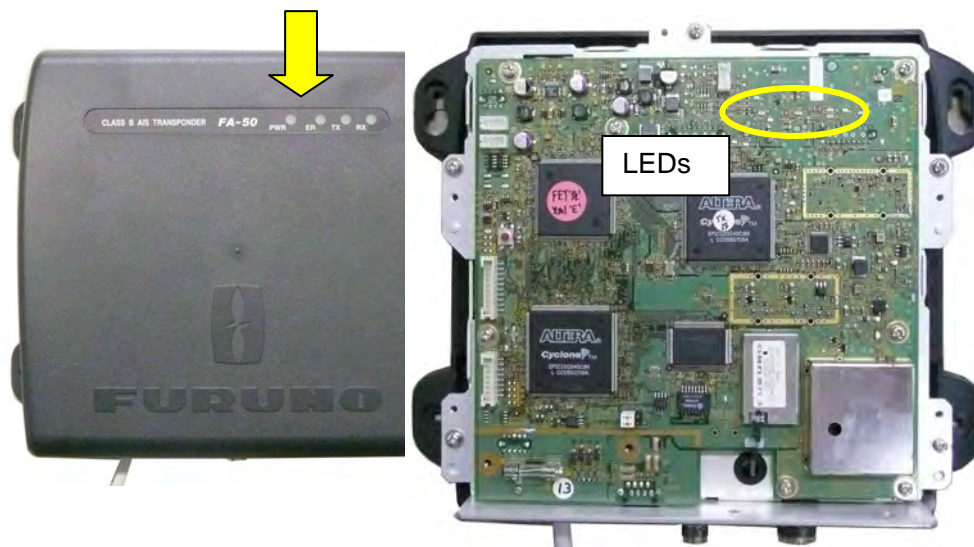

2. NETWORK port LEDs

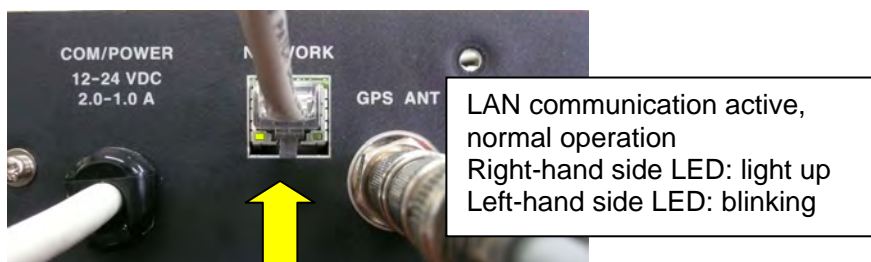

Q1. Can messages be exchanged between Class A and B system? 1-13

Yes. However, the Message number of static data and the dynamic data is different.

Q2. What are differences between Class A units and Class B (CS) device? AP3-1

While both devices use a same packet format, Class A device method SOTDMA (Self Organized Time Division Multiple Access) technology in synchronization with UTC and Class B device method CSTDMA (Carrier Sensing Time Division Multiple Access) technology.

In the CSTDMA technology, to avoid interfering a transmission schedule of a class A station, transmissions from the class A station are monitored using a carrier sensing (CS) function and, when no transmitting wave is detected, a transmission from the own unit can be conducted.

Q3. How are the report messages handled? 1-13, AP3-5

Those messages are handled in different manners by the Class A FA-150 and Class B (CS) FA-50.

Dynamic data is handled in MSG.1, 2, and 3 on Class A device, while MSG.18 on Class B device; a report is sent at intervals ranging from 2 seconds to 3 minutes by Class A device, while at intervals of 3 minutes if 2 kt or less, or at intervals of 30 seconds if faster than 2 kt by Class A device.

Static data is handled in MSG.5 on Class A device, while MSG.24A and B on Class B device, and such messages are sent at intervals of 6 minutes.

Q4. Service area? 1-13

Class B system offers a facility for small ships including Non-SOSAL ships with Tx output power of 2 W. Depending on the antenna height, it is generally assumed as 5 to 8 nm between ships and 20 nm between a coastal station and a ship.

Q5. Is it possible to receive a DSC distress alert? 8-18

Yes. However, only Japanese PC-MKD Spc.: FAISPC_B in the position data of the distress ship can be displayed. No data is displayed on the external display devices such as NAVNET3 and Radar screens.

DSC and AIS signals are not continuously received because they are listened by a time-sharing method. Also responding to the received Distress alert with a receipt acknowledgement is not allowed.

Q6. Is DSC reception continuously performed? 8-18

No. DSC and AIS signals are not continuously received because they are listened by a time-sharing method.

Q7. Is there any method to set the unit to receive-only? 8-20

Yes. Select For Service -> Other and set [Silent Mode] to "On" to add an item of [Silent] to the Top page of the Web browser screen. Then open the Silent menu, where you can choose "Rx Only" to set to receive-only or "Normal" to the normal mode.

Q8. Is the tanker mode available? 2-10

Yes. Select Initial Setup -> Ship Static Edit, where set [Ship Type] to “Tanker” to enter the Tanker Mode. In the Tanker Mode, an item of “Tx Power” is added in the top page of the Web browser screen and clicking it allows you to manually select Tx output power.

Q9. In the Demo mode, is the own ship position data required? 8-8

No. It is not required to connect with any sensor inputs of, for example, the built-in GPS or the external GPS.

Q10. Is it required to connect with the external sensors of, for example, the external GPS?

No, it is not required. This is also not required for HDG. ROT does not need to be connected because it is not defined in the dynamic data.

Q11. Is it required to connect with the HDG data input?

No, it is not required.

Q12. Is it allowed to use the combined antenna of FA-150? 1-2

Yes. It can be used on both equipment.

Q13. How much is the power source voltage? 5-11, 3-2

FA-50 operates on a power supply voltage from +9.6 to +31.2 VDC. If the power supply voltage goes out of spec, an input low-voltage protection circuit or an input over-voltage protection circuit is activated to prohibit from power on. And functions of short-circuit protection and power supply reverse connection protection are implemented by a midget fuse: 125 V/4 A. This fuse is installed on the MAIN&TX board.

Q14. What is a password?

It is described in Furnuno Information: FQ4-2009-014.

A password to access the For Service menu is same as the one for GMDSS, for example, FS-2570.

To enter the Ship Static Edit menu from Initial Setup, Login Name: “furunoservice” and Password: model name must be entered.

Q15. How to connect to the Radar. 1-8

FR-8002 series Radar cannot directly connect to the FA-50.

IF-1500AIS interfaces between the COM port(FA-50) and the NMEA port(FR-8002). It is because FR-8002 is not provided with a function for screening and sorting AIS targets. IF-1500AIS does this process and outputs the results by PFEC sentences to FR-8002. FR-2xx7 series Radar can be directly connected to the COM port.

Q16. How to setup the connection between FA-50 and NAVNET 3. 2-7

Firstly, establish a LAN connection.

To setup NAVNET 3, select Installation Wizard -> DHCP Server and set it "ON"; then open the [Global] tag, select Data Source and set AIS: "FA-50".

Q17. Although HDG data has not been inputted to the FA-50, HDG data is displayed on the FA-50 screen after connecting to NAVNET 3. 2-7

It is because NAVNET 3 is set so as to share the Heading Data with FA-50.

To share the Heading data, select Installation Wizard -> DHCP Server and set it "ON"; then open the [Own] tag and select the NMAE Port1: Heading connection port, where Input Source type should be set to "Heading".

Q18. Although the IP address is entered in the URL field, the Web browser screen of FA-50 does not appear. 1-4

Make sure that the network setup of the PC has been correctly defined and the network connection is normally established. If they are OK, the IP address of FA-50 may have been changed.

To reset the IP address of FA-50 to the initial value, set the DIP switch: S4-#2 to the ON position and reboot the FA-50. Then the DIP switch: S4-#2 must be reset from "ON" to "OFF".

Q19. What are the values of the allowable error of Tx power output and the frequency deviation? 7-2

According to the IEC62287 standard, the allowable error of Tx power output is ± 1.5 dB, frequency deviation is ± 500 Hz.

Q20. Where is the adjustment of Tx output power made? 7-6

It is made by using R24 on the MAIN & TX board.

Using a thin screwdriver, R24 can be adjusted through a hole provided on the shield cover.

To perform a continuous transmission, press SW2 (the red button SW) on the MAIN&TX board or select For Service -> Device Test -> TX Test. In either case, a continuous transmission is allowed only for 15 seconds.

Q21. Is there any simple way to measure the sensitivity on SSG? 8-12

Enter an AIS Rx frequency from SSG and select For Service -> Device -> RSSI Test, you can see the value you need. For an input value of -110 dBm, "16" or so can be displayed.

Q22. Only few targets can be received. How to check this problem?**8-12, 8-16**

It could be a failure of the antenna, Rx sensitivity, or operation channel. Any failure on the RX1 & 2 boards can be checked by selecting For Service -> Device Test -> RX Test (Loop Back).

Or, if you are in the sea area during “Regional operating areas”, select Own Vessel Data -> View Channel to check the current operation channel. If the current channel differs from the operation channel specified, select For Service -> Channel and set the correct operation channel by “Manual” to be able to receive area data and perform the “Regional operating areas”. Channel Selection must be reset to “Auto” afterward.

Q23. Is it allowed to common use of the “Rx A” and “Rx B” ?**5-4**

No. It is not allowed because the different 1st IF is used, its frequency is “51.136 MHz” on RX1 (05P0808A), and “51.236 MHz” on RX2 (05P0808B).

Q24. About the panel LED indicators.**3-1, 8-27**

Normally, only the power LED (green) lights up. The TX LED lights up in “blue” during transmission or "yellow" when an unregistered MMSI is detected.

The RX LED lights up at reception. The ERR LED lights up in “red” when a ROM/RAM failure or a transmission error is detected. It does not mean an error when a sensor input is interrupted.

Q25. What is the red switch on the MAIN&TX board for?**7-5**

This is the “S2” switch. Pressing this switch brings about a continuous transmission state for 15 seconds to allow measurement of the transmission output and frequency.

To conduct a transmission control from the menu, select For Service -> Device Test -> Tx Test and click [Start].

Q26. Is there any method to cease External EPFS ALM?**8-3**

Yes. Select For Service -> NMEA -> EPFS ALM and set it “OFF”.

Q27. How to do a program update.**Chapter 6**

LAN connection of PC and FA-50 should be connected via HUB.

To update the program, click on a batch file: nUPFA50 and power on the FA-50.

Then an update process automatically starts and completes within 20 seconds or so.

If no HUB is installed, use a cross cable to establish a LAN connection and click the batch file and power on the FA-50 immediately.

Q28. Is it allowed to edit a short message?**8-19**

Yes. To do this, select Service -> Edit Message. For Class B system, such a short message must be a safety related MSG.14 broadcasting to all vessels and have been once edited. It can contain 16 characters at maximum.

Q29. The HDG data inputted from the COM port is not accepted.**8-13, 8-14**

Select For Service -> Device Test -> COM Port Test and conduct a loop back test of the COM port. If NG, a failure exists on the MAIN&TX board.
If talker is "HC", the data is invalid.

Q30. Abnormal operations are observed.**8-15**

Execute the steps as follows: For Service -> Memory Clear -> Factory Rest.

Q31. What settings are required to be set by a user?**2-8**

They are items in the menu shown by selecting Initial Setup -> Ship Static Edit. If MMSI is not registered, the TX LED lights up in "orange" and no transmission is allowed. To other settings, the factory defaults can be applied.

Q32. What items are required to be checked?**2-11, 8-11, 8-19**

They include the following: Internal GSP should receive signals, the registration data in Own Vessel Data is correct, and being capable of receiving. If a failure is suspected during reception, follow the steps: For Service -> Device Test -> RX Test (Loop Back) and run the test.

Q33. No AIS data is displayed.**2-6**

Select Initial Setup -> Network Setup -> AIS Data Output, check if the setting is Continuous: GPS, ZDA. If so, change it to Continuous: AIS.

Q34. About requirements for transmission.

To start a transmission, MMSI registration must be done and the built-in GPS has determined positions.

After power on, the system boots up and a reporting process starts 1 minute later. At this point of time, however, the built-in GPS must have determined positions.

Q35. How to confirm that the external GPS data has been inputted.

Note that, if the built-in GPS does not determine positions, no external GPS data can be used.

Select For Service -> NMEA -> EPFS Alarm and set it "ON" and check for an EPFS alarm. If no EPFS alarm is appeared, it is OK.

Q36. Does the reporting rate change immediately following a change of the ship speed?**AP3-1**

When the ship speed goes up across 2 knot, the reporting rate immediately changes to a cycle of 30 seconds.

In contrast to this, when the ship speed goes down across 2 knot, the reporting rate does not change to a cycle of 3 minutes unless the same ship speed is kept for 3 minutes or longer.

Q37. What conditions should be met when using the external GPS?

8-7, AP3-1

Priority of GPS is defined as the following:

external DGPS > built-in DGPS > external GPS > built-in GPS

If the built-in GPS does not determine positions, no external GPS data is used.

To use the external GPS, must be met the following conditions:

- 1) The datum of the external GPS should be WGS84.
- 2) GBS should be received and expected deviations of the latitude and longitude should be less than 10 m respectively.
- 3) The external GPS-determined position should be within 26 m of the built-in GPS-determined position.
- 4) IEC 61162-1 including Mode Indicator and Check Sum should be satisfied.

Appendix 1. Specifications

1. GENERAL

1.1 Type	Class B AIS Transponder
1.2 RX capacity	2250 report/minute, 1channel 4500 report/minute, 2channel
1.3 RX system	CSTDMA dual wave simultaneous reception
1.4 Synchronous framing	Indirect synchronize from external oscillator
1.5 Operating mode	Autonomous, Assigned, polled/interrogation response
1.6 Frequency switching	Automatic
1.7 Prevention of abnormal TX:	Auto-suspend for detecting TX more than 1 second
1.8 Regulations	IMO MSC.140 (76), IEC 62287-1, ITU-R M.1371-2, DSC ITU R M.825-3, IEC 60945 ed.4 adopted

2. TRANSMITTER

2.1 Frequency range	156.025 MHz to 162.025 MHz (F1D)
2.2 Output power	1 W/2 W
2.3 Channel interval	25 kHz
2.4 Frequency deviation	± 3 ppm or less
2.5 Transmit speed	9600 bps ± 50 ppm
2.6 Spurious Emission	9 kHz to 1 GHz, -36 dBm or less 1 GHz to 4 GHz, -30 dBm or less

3. AIS RECEIVER

3.1 Frequency range	156.025 MHz to 162.025 MHz (DSC: 156.525 MHz)
3.2 Oscillator frequency	1st local oscillator: $f + (51.136/51.236 \text{ MHz})$ 2nd local oscillator: 51.1/51.2 MHz
3.3 Intermediate frequency	1st: 51.136/51.236 MHz, 2nd: 36 kHz
3.4 Receiving system	Double-conversion superheterodyne
3.5 Sensitivity	-107 dBm (PER 20% or less)
3.6 Error at high input level	-7 dBm
3.7 Co-channel rejection	10 dB
3.8 Adjacent channel selectivity:	70 dB
3.9 Spurious response	70 dB (50 MHz to 520 MHz)

- 3.10 Inter-modulation 65 dB
- 3.11 Sensitivity suppression 86 dB (± 5 MHz, ± 10 MHz)

4. DSC RECEIVER (TIMESHARING SYSTEM)

- 4.1 Frequency 156.525 MHz (CH70)
- 4.2 Sensitivity -107 dBm or less
- 4.3 Error at high input level -7 dBm
- 4.4 Co-channel rejection 10 dB
- 4.5 Adjacent channel selectivity 70 dB
- 4.6 Spurious response 70 dB
- 4.7 Inter-modulation 65 dB
- 4.8 Sensitivity suppression 84 dB

5. GPS RECEIVER

- 5.1 Receiving frequency 1575.42 MHz
- 5.2 Tracking code C/A code
- 5.3 Number of channel 12 channels parallel, 12 satellites
- 5.4 Position fixing method All in view, 8-state Kalman filter
- 5.5 Position accuracy 10 m approx., 95% of the time,
(HDOP ≤ 4) DGPS: 5m approx., 95% of the time
- 5.6 Tracking velocity 900 kts
- 5.7 Position fixing time Warm start: 36 s typical, Cold start: 43 s typical
- 5.8 Geoids WGS84
- 5.9 Position update interval 1 s
- 5.10 DGPS data correcting By AIS information

6. INTERFACE

6.1 COM I/O

Input: RS-422 (38.4kbps) / IEC61162-1 (4800bps)
ACK, BBM, DTM, GBS, GGA, GLL, GNS, HDT,
OSD, RMC, SSD, VBW, VSD, VTG, AIQ, DSC,
DSE, PFEC

Output:	RS-422 (38.4kbps) ABK, ACA, ACS, ALR, VDM, VDO, TXT, PFEC
6.2 NETWORK	Ethernet 10BASE-T/100BASE-TX
Input:	ACK, BBM, DTM, GBS, GGA, GLL, GNS, HDT, OSD, RMC, SSD, VBW, VSD, VTG, AIQ, DSC, DSE, PFEC
Output: ABK,	ACA, ACS, ALR, GGA, VDM, VDO, VTG, ZDA, TXT, PFEC
6.3 Function alarm	LED indication, series data output

7. POWER SUPPLY

12 to 24 VDC: 2.0 to 1.0 A

8. ENVIRONMENTAL CONDITIONS

8.1 Ambient temperature

Antenna unit	-30°C to +70°C
Transponder	-15°C to +55°C

8.2 Relative humidity 93% at +40°C

8.3 Degree of protection

Antenna unit	IPX6
Transponder	IP20

8.4 Bearing vibration IEC 60945

9. COATING COLOR

9.1 GPS antenna unit	N9.5
9.2 Transponder	N2.5

Appendix 2. Channel Lists

The operation channels of Class B (CS) AIS should be the channels with a bandwidth of 25 kHz specified in R/R AP-18, ITU-R Rec. M.1084-4.

The channel numbers assigned to the Duplex channels for the purpose of Simplex operation are determined as described below:

- For Simplex operation of the Ship station frequency, 1000 + Duplex channel.
For example, for the channel number of “1060” assigned to the channel 60, both transmission and reception are carried out at 156.025 MHz.
- For Simplex operation of the Coast station frequency, 2000 + Duplex channel.
For example, for the channel number of “2060” assigned to the channel 60, both transmission and reception are carried out at 160.625 MHz.
- Simplex channels are indicated by one/two-digit channel number.

1. International Mode Channel

Ch No.	Frequency	Ch No.	Frequency
1001	156.05	2001	160.65
1002	156.1	2002	160.7
1003	156.15	2003	160.75
1004	156.2	2004	160.8
1005	156.25	2005	160.85
6	156.3		
1007	156.35	2007	160.95
8	156.4		
9	156.45		
10	156.5		
11	156.55		
12	156.6		
13	156.65		
14	156.7		
15	156.75		
16	156.8		
17	156.85		
1018	156.9	2018	161.5
1019	156.95	2019	161.55
1020	157.0	2020	161.6
1021	157.05	2021	161.65
1022	157.1	2022	161.7
1023	157.15	2023	161.75

Ch No.	Frequency	Ch No.	Frequency
1024	157.2	2024	161.8
1025	157.25	2025	161.85
1026	157.3	2026	161.9
1027	157.35	2027	161.95
1028	157.4	2028	162.0
1060	156.025	2060	160.625
1061	156.075	2061	160.675
1062	156.125	2062	160.725
1063	156.175	2063	160.775
1064	156.225	2064	160.825
1065	156.275	2065	160.875
1066	156.325	2066	160.925
67	156.375		
68	156.425		
69	156.475		
70	156.525		
71	156.575		
72	156.625		
73	156.675		
74	156.725		
75	156.775		
76	156.825		
77	156.875		
1078	156.925	2078	161.525
1079	156.975	2079	161.575
1080	157.025	2080	161.625
1081	157.075	2081	161.675
1082	157.125	2082	161.725
1083	157.175	2083	161.775
1084	157.225	2084	161.825
1085	157.275	2085	161.875
1086	157.325	2086	161.925
1087	157.375	<i>2087 (International AIS CH)</i>	<i>161.975</i>
1088	157.425	<i>2088 (International AIS CH)</i>	<i>162.025</i>

2. USA Mode Channel

To enter the USA Mode, from [For Service], Click and Open [Other], where “Channel Selection” can be set to “USA”. In the USA Mode, CH1002, 1004, 1060, 1062 are eliminated from the International Mode. CH13 and 67 operate at 1 W.

Ch No.	Frequency	Ch No.	Frequency
1001	156.05	2001	160.65
		2002	160.7
1003	156.15	2003	160.75
		2004	160.8
1005	156.25	2005	160.85
6	156.3		
1007	156.35	2007	160.95
8	156.4		
9	156.45		
10	156.5		
11	156.55		
12	156.6		
13	156.65		
14	156.7		
15	156.75		
16	156.8		
17	156.85		
1018	156.9	2018	161.5
1019	156.95	2019	161.55
1020	157.0	2020	161.6
1021	157.05	2021	161.65
1022	157.1	2022	161.7
1023	157.15	2023	161.75
1024	157.2	2024	161.8
1025	157.25	2025	161.85
1026	157.3	2026	161.9
1027	157.35	2027	161.95
1028	157.4	2028	162.0
		2060	160.625
1061	156.075	2061	160.675
		2062	160.725

Ch No.	Frequency	Ch No.	Frequency
1063	156.175	2063	160.775
1064	156.225	2064	160.825
1065	156.275	2065	160.875
1066	156.325	2066	160.925
67	156.375		
68	156.425		
69	156.475		
70	156.525		
71	156.575		
72	156.625		
73	156.675		
74	156.725		
75	156.775		
76	156.825		
77	156.875		
1078	156.925	2078	161.525
1079	156.975	2079	161.575
1080	157.025	2080	161.625
1081	157.075	2081	161.675
1082	157.125	2082	161.725
1083	157.175	2083	161.775
1084	157.225	2084	161.825
1085	157.275	2085	161.875
1086	157.325	2086	161.925
1087	157.375	<i>2087 (International AIS CH)</i>	<i>161.975</i>
1088	157.425	<i>2088 (International AIS CH)</i>	<i>162.025</i>

Appendix 3. Class B AIS (CS) System

AP3.1 Overview of Class B (CS)

Class B AIS system has two types, CSTDMA and SOTDMA (Class A).

The FA-50 is Class B AIS device using CSTDMA (Carrier Sense TDMA) technology developed for Non-SOLAS ships.

Class B AIS device should comprise one transmission and reception processes for two AIS TDMA signals and one DSC (CH70).

The process of DSC reception can be accomplished by time-sharing between TDMA and DSC. The FA-50 use a time-sharing method, while observing the watching times as described below:

Minutes past UTC hour	
05:30 – 05:59	35:30 – 35:59
06:30 – 06:59	36:30 – 36:59
20:30 – 20:59	50:30 – 50:59
21:30 – 21:59	51:30 – 51:59

AP3.1.1 Differences between Class A and Class B

1. Dynamic Data

Class A AIS device transmits dynamic data reports using MSG.1, 2, 3. Class B AIS device does this using MSG.18. MSG.18 is transmitted at reporting intervals as described below, unless directed by MSG.23.

- If SOG is greater than 2 knots: 30 seconds
- If SOG is 2 knots or less: 3 minutes

Note:

When the ship speed goes up across 2 knots, the reporting rate immediately changes to a cycle of 30 seconds. In contrast to this, when the ship speed goes down across 2 knots, the reporting rate does not change to a cycle of 3 minutes unless the same ship speed is retained for 3 minutes or longer.

The position data and SOG/COG data to be reported are derived from the same GPS receiver. As a requirement, a GPS receiver must be built in the system.

Optionally, GPS data from external devices can be used.

In this case, the following conditions must be met.

- The datum of the external GPS should be WGS84. And the DTM sentence is outputted and the coordinates of WGS-84 are determined.
- A valid RAIM sentence (GBS) should be received and expected deviations of the latitude and longitude should be less than 10 m.

- The external GPS-determined position should be within 26 m of the built-in GPS-determined position.
- The data format complies with IEC 61162-1 including Mode Indicator and Check Sum.

Note:

It is not required to connect Class B AIS device with the external GPS data. The heading data input is also optional. No ROT data is included in the report so that its input is not necessary.

2. Static Data

Class A AIS device transmits static data reports using MSG.5.

Class B AIS device does this using MSG. 24 (24A, 24B). As with Class A, these messages are transmitted every 6 minutes. A message should be also transmitted when a data change occurs.

These messages should be transmitted separately in two parts, where MSG. 24B is transmitted within 1 minute following MSG. 24A.

- MSG. 24A: Ship name etc.
- MSG. 24B: Ship type/Cargo type, Vendor ID, Call sign, Ship size etc.

3. Transmitting Short Messages

Class A AIS device is allowed to transmit all of the following sentences: MSG. 6: Addressed Binary Message, MSG. 8: Binary Broadcast Message, MSG.12: Safety Related Broadcast Message, MSG.14: Safety Related Broadcast Message.

Class B AIS device is allowed to transmit only safety (broadcast) -related messages: MSG.14 and users should select one from the pre-configured messages.

These messages can contain 16 characters maximum and be transmitted only once in a minute.

On the Web browser screen of FA-50, open [Send Message] from the Message menu and select and send a message among the pre-edited messages. To edit a message, go to the [Edit Message] screen from the “For Service” menu.

4. Initialization Report

At power on, Class B AIS device monitors TDMA channels for 1 minute synchronizing with the signals received from Class A AIS stations to determine a Carrier Sense: CS detection threshold.

If an empty slot is found, MSG.18, as a first report, is transmitted.

At power on, Class A AIS device monitors VHF links for 1 minute synchronizing with UTC to enter the network. MSG.1, as a first report, is transmitted.

5. Packet Format

In both Class A and B AIS, it takes about 26.7 ms to complete a transmission of one packet. From Training sequence to End flag, a packet is configured in the same manner in both Class A and B. Differences are found in the Start-Buffer and the End-Buffer. While a value of 12 bits in the End-Buffer is reserved for a distance delay equivalent to a delay distance of 100 nm for Class A, a value of 2 bits equivalent to a delay distance of 30 nm for Class B.

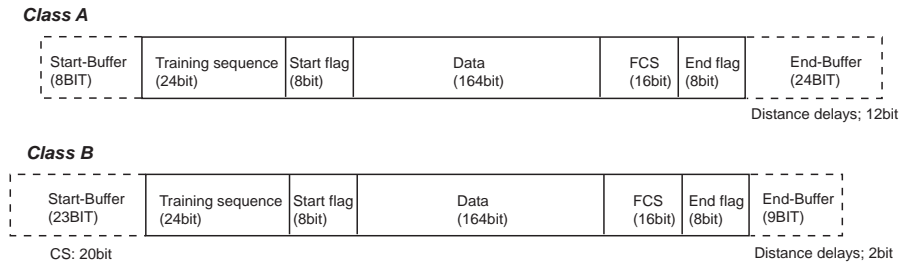

6. Carrier Sense (CS) Detection

Class B (CS) AIS device monitors transmissions from a Class A station using a carrier sense (CS) function to avoid interfering a transmission schedule of the Class A station, and, only when no transmission signal is detected, an own transmission can be conducted.

The CS function monitors reception signal levels and, when a signal level greater than the predefined CS threshold is detected, terminates the transmission. This function, however, is operable for the signals from Class A stations and not to those from Class B stations.

Tips: The CS detection threshold should be determined based on the reception noise levels measured for previous 60 seconds on each reception channel separately. The threshold should be determined by measuring the background noise: the minimum energy level and adding an offset of 10 dB to the measurement. The minimum CS detection threshold should be -107 dBm. The value of -107 dBm is a minimum sensitivity value required.

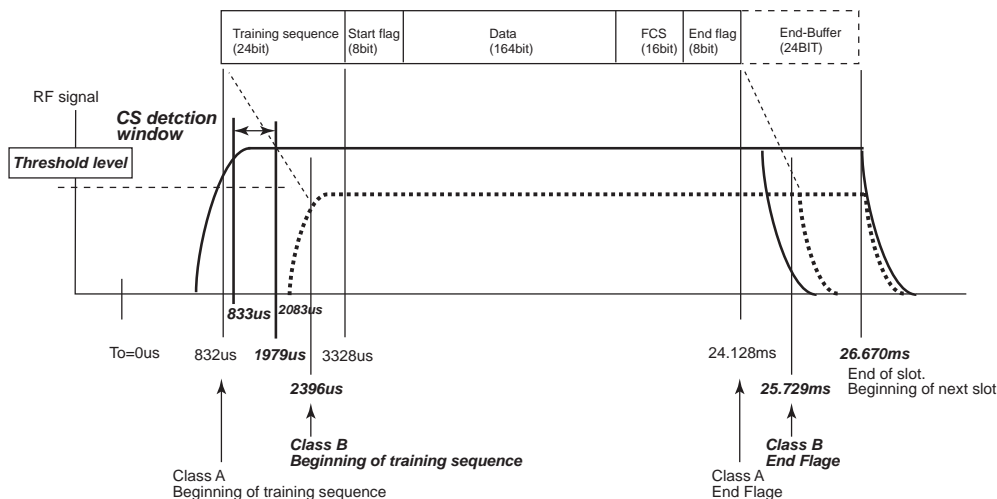

7. Reporting Method

Class A AIS device is a system synchronizing with UTC.

Class B AIS device synchronizes with the position reports, such as MSG.1, 2, and 3, from Class A AIS device and uses them to determine the CS: Carrier Sense.

If no report can be received from Class A stations, Class B equipment conducts transmissions at own intervals and, when any signal from a Class A station is received, it synchronizes with that station.

Reporting is performed as described below.

Term	Description	Value
Reporting Interval (RI)	Reporting interval as specified	SOG > 2kt: 30 sec. SOG ≤ 2kt: 3 min.
Nominal Transmission Time (NTT)	Nominal time-period for transmission defined by RI	
Transmission Interval (TI)	Time interval of possible transmission periods, centred around NTT	TI= RI/3 or 10 s whichever is less
Candidate Period (CP)	Time-period where a transmission attempt is made (excluding time periods indicated unavailable)	
Number of CP in TI		10

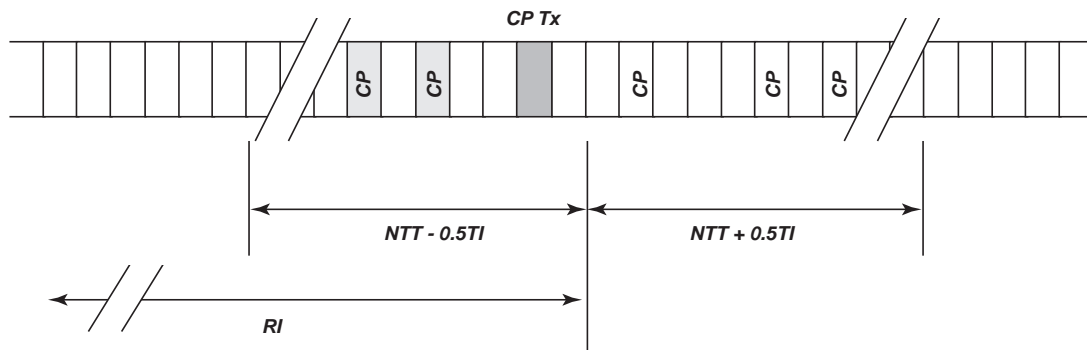

- 1) Randomly define a CP: Candidate Period for reporting “10” in the TI.
- 2) Starting with the first CP in TI, test for CS and transmit if the status of CP is “unused”, otherwise wait for the next CP.
- 3) A transmission should be abandoned if all 10 CPs are “used”; then the operation proceeds to the next reporting period.

AP3.2 VDL Messages

MSG No.	Message	FA-50 Rx	FA-50 Tx	Remark
1	Position Report (Scheduled)	Opt (Yes)	No	
2	Position Report (Assigned)	Opt (Yes)	No	
3	Position Report (When interrogated)	Opt (Yes)	No	
4	Base Station Report	Opt (Yes)	No	
5	Static and Voyage Related Data	Opt (Yes)	No	
6	Addressed Binary Message	No	No	
7	Binary Acknowledge	No	No	
8	Binary Broadcast Message	Opt (Yes)	No	
9	Standard SAR Aircraft Position Report	Opt (Yes)	No	
10	UTC and Date Inquiry	No	No	
11	UTC/Date Response	Opt (Yes)	No	
12	Safety Related Addressed Message	Opt (Yes)	No	Note) Information can also be transferred via Message 14
13	Safety Related Acknowledge	No	Opt	Shall be transmitted if the option to process Message 12 is implemented
14	Safety Related Broadcast Message	Opt (Yes)	Opt	Transmit with predefined text only,
15	Interrogation	Yes	No	Class B"CS" shall respond to interrogations for Message 18 and Message 24 It shall also respond to interrogations for Message 19 by a Base Station
16	Assigned Mode Command	No	No	(Message 23 is applicable to the"CS" instead)
17	DGNSS Broadcast Binary Message	Opt (Yes)	No	
18	Standard Class B Equipment Position Report	Opt (Yes)	Yes	A Class B"CS" AIS shall indicate "1" for "CS" in flag bit 143
19	Extended Class B Equipment Position Report	Opt (Yes)	Yes	Transmit ONLY as response to Base Station interrogation
20	Data Link Management Message	Yes	No	
21	Aids-to-Navigation Report	Opt (Yes)	No	
22	Channel Management Message	Yes	No	Use of that function may be different in certain regions
23	Group Assignment	Yes	No	
24	Class B(CS) Static data	Opt (Yes)	Yes	There are Part A and Part B.

AP3.3 Configurations of Transmission Messages

AP3.3.1 Message 14

Use of Safety Related Broadcast Message

The contents of Message 14 should be preconfigured and the transmission should not exceed one-time period. The table below specifies the maximum number of data bits used for Message 14 and, based on the assumption that the theoretical maximum of stuffing bits will be needed.

Number of time periods	Maximum data bits	Stuffing bits	Total buffer bits
1	136	36	56

The Class B “CS” AIS should only accept an initiation of Message 14 only once a minute by a user manual input. Automatic repetition is not allowed.

The Message 14 may have precedence over Message 18.

AP3.3.2 Message 18

Class B Position Report

Class B Position Report must be periodically and autonomously conducted.

Parameter	Number of bits	Description
Message ID	6	Identifier for Message 18; always 18
Repeat indicator	2	Used by the repeater to indicate how many times a message has been repeated. 0-3; shall be 0 for Class B“CS” transmissions
User ID User ID	30	MMSI number
Reserved for regional or local applications	8	Reserved for definition by a competent regional or local authority. Shall be set to zero, if not used for any regional or local application.
SOG	10	Speed over ground in 1/10 kn steps (0-102.2 kn) 1 023 = not available, 1 022 = 102.2 kn or higher
Position accuracy	1	1 = high (<10 m) 0 = low (>10 m) shall be combined with RAIM information if available
Longitude	28	Longitude in 1/10 000 min (± 180 degrees, East = positive (as per 2’s complement), West = negative (as per 2’s complement). 181 degrees (6791AC0 hex) = not available = default
Latitude	27	Latitude in 1/10 000 min (± 90 degrees, North = positive (as per 2’s complement), South = negative (as per 2’s complement), 91 degrees (3412140 hex) = not available = default

COG	12	Course over ground in 1/10° (0-3 599), 3 600 (E10h) = not available = default; 3 601-4 095 shall not be used
True heading	9	Degrees (0-359) (511 indicates not available = default)
Time stamp	6	UTC second when the report was generated by the EPFS (0-59 60 if time stamp is not available, which shall also be the default value 61, 62, 63 are not used by the Class B"CS" AIS
Reserved for regional applications	2	Reserved for definition by a competent regional authority. Shall be set to zero, if not used for any regional application. Regional applications should not use zero
Class B unit flag	1	0 = Class B SOTDMA unit (shall not be used for the Class B"CS") 1 = Class B"CS" unit
Class B display flag	1	0 = No display available; not capable of displaying Messages 12 and 14 1 = Equipped with integrated display displaying Messages 12 and 14
Class B DSC flag	1	0 = not equipped with DSC function 1 = equipped with DSC function (dedicated or time-shared)
Class B band flag	1	0 = Capable of operating over the upper 525 kHz band of the marine band 1 = Capable of operating over the whole marine band (irrelevant if Class B Message 22 flag is 0)
Class B Message22 flag	1	0 = No Frequency management via Message 22 , operating on AIS 1, AIS 2 only 1 = Frequency management via Message 22
Mode Flag	1	0 = Station operating in autonomous mode = default 1 = Station operating in assigned mode
RAIM-flag	1	RAIM flag of electronic position fixing device; 0 = RAIM not in use = default; 1 = RAIM in use (valid data for expected position error)
Communication state selector flag	1	1 = ITDMA communication state follows
Communication state	19	ITDMA communication state (1100000000000000110)
Total number of bits	168	Occupies one time period

AP3.3.3 Message 24

Class B (CS) Static data

This message shall be used by Class B “CS” shipborne mobile equipment. This message consists of two parts: A and B. Message 24B should be transmitted within 1 min following Message 24A.

In the case of an interrogation for Message 24, the response should include both Part A and B.

Message 24 Part A:

Parameter	Number of bits	Description
Message ID	6	Identifier for Message 24; always 24
Repeat indicator	2	Used by the repeater to indicate how many times a message has been repeated. 0 = default; 3 = do not repeat any more
User ID	30	MMSI number
Part number	2	Identifier for the message part number; always 0 for Part A
Name	120	Maximum 20 characters 6-bit ASCII, @@@@ = not available = default
Total number of bits	160	Occupies one time period

Message 24 Part B:

Parameter	Number of bits	Description
Message ID	6	Identifier for Message 24; always 24
Repeat indicator	2	Used by the repeater to indicate how many times a message has been repeated. 0 = default; 3 = do not repeat any more
User ID	30	MMSI number
Part number	2	Identifier for the message part number; always 1 for Part B
Type of ship and cargo type	8	0 = not available or no ship = default 1-99 = as defined in § 3.3.8.2.3.2 of ITU-R M.1371-1 100-199 = preserved, for regional use 200-255 = preserved, for future use
Vendor ID	42	Unique identification of the Unit by a Number as defined by the manufacturer (option; "#####" = not available = default).
Call Sign	42	Call sign of the MMSI-registered vessel. 7 x 6 bit ASCII characters, "#####" = not available = default.
Dimension of ship/reference for position	30	Dimensions of ship in meters and reference point for reported position (see ITU-R M.1371-1)
Spare	6	
Total number of bits	168	Occupies one time period

AP3.3.4 Message 23

Group Assignment Command

The group assignment command is issued by a base station using an operation management message addressing to Class B AIS stations.

Parameter	Number of bits	Description
Message ID	6	Identifier for Message 23; always 23
Repeat Indicator	2	Used by the repeater to indicate how many times a message has been repeated. 0 – 3; default = 0; 3 = do not repeat any more
Source ID	30	MMSI of assigning station
Spare	2	Spare. Shall be set to zero
Longitude 1	18	Longitude of area to which the group assignment applies; upper right corner (north-east); in 1/10 min ($\pm 180^\circ$, East=positive, West=negative)
Latitude 1	17	Latitude of area to which the group assignment applies; upper right corner (north-east); in 1/10 min ($\pm 90^\circ$, North=positive, South=negative)
Longitude 2	18	Longitude of area to which the group assignment applies; lower left corner (south-west); in 1/10 min ($\pm 180^\circ$, East=positive, West=negative).
Latitude 2	17	Latitude of area to which the group assignment applies; lower left corner (south-west); in 1/10 min ($\pm 90^\circ$, North=positive, South=negative)
Station type	4	0 = all types of mobiles (default); 1 = reserved for future use; 2 = all types of Class B mobile stations; 3 = SAR airborne mobile station; 4 = AtoN station; 5= Class B"CS" shipborne mobile station (IEC 62287 only); 6 = inland waterways; 7 to 9 = regional use; 10 to 15 = for future use
Type of ship and cargo type	8	0= all types (default) 1...99 see Table 19 of ITU-R M.1371-1 100...199 reserved for regional use 200...255 reserved for future use
Spare	22	Reserved for future use. Not used. Shall be set to zero
Tx/Rx mode	2	This parameter commands the respective stations to one of the following modes: 0 = TxA/TxB, RxA/RxB (default); 1 = TxA, RxA/RxB , 2 = TxB, RxA/RxB, 3 = reserved for future use
Reporting Interval	4	This parameter commands the respective stations to the reporting interval given in next page Table
Quiet Time	4	0 = default = no quiet time commanded; 1 – 15 = quiet time of 1 to 15 min
Spare	6	Spare. Not used. Shall be set to zero
Total	160	Occupies one time period

Reporting interval settings using Message 23

Reporting interval field setting	<u>Reporting interval for Message18</u>
0	As given by the autonomous mode
1	10 min
2	6 min
3	3 min
4	1 min
5	30 s
6	15 s
7	10 s
8	5 s
9	Next shorter reporting interval
10	Next longer reporting interval
11 – 15	Reserved for future use

Note:

If the dual channel operation is interrupted by the Tx/Rx mode command 1 or 2, the values of reporting intervals shown above become doubled.

AP3.4 Regional operating area

The FA-50 stores three types of area data concerning the Channel management area, Assigned area, and Quiet area. When the own ship stays in either of these areas, the corresponding rule should be observed during each operation.

AP3.4.1 Channel Management

This is an area designated by DSC or Message22 transmitted from a base station. While the own ship stays in either of these areas, the area data specified for the corresponding area, such as channel, transmission power and etc., should be used during operation.

The sea area excluding the area designated by a base station is international waters and used by the next channel for operation.

- Channel A: 2087 • Channel B: 2088
- Zone size: 5 nm • Transmission power: 2 W (1 W in the Tanker mode)
- Tx/Rx Mode: dual channel transmission/reception

Contents of Message22

Parameter	Number of bits	Description
Message ID	6	Identifier for Message 22; always 22
Repeat indicator	2	Used by the repeater to indicate how many times a message has been repeated. See § 4.6.1; 0-3; 0 = default; 3 = do not repeat any more
Station ID	30	MMSI number of base station
Spare	2	Not used. Should be set to zero
Channel A	12	Channel number according to Recommendation ITU-R M.1084, Annex 4
Channel B	12	Channel number according to Recommendation ITU-R M.1084, Annex 4
Tx/Rx mode	4	0 = Tx A/Tx B, Rx A/Rx B (default) 1 = Tx A, Rx A/Rx B 2 = Tx B, Rx A/Rx B 3-15: not used
Power	1	0 = high (default), 1 = low
Longitude 1, (or 18 most significant bits (MSBs) of addressed station ID 1)	18	Longitude of area to which the assignment applies; upper right corner (north-east); in 1/10 min, or 18 MSBs of addressed station ID 1 ($\pm 180^\circ$, East = positive, West = negative). 181 = not available
Latitude 1, (or 12 least significant bits (LSBs) of addressed station ID 1)	17	Latitude of area to which the assignment applies; upper right corner (north-east); in 1/10 min, or 12 LSBs of addressed station ID 1, followed by 5 zero bits ($\pm 90^\circ$, North = positive, South = negative). 91° = not available

Longitude 2, (or 18 MSBs of addressed station ID 2)	18	Longitude of area to which the assignment applies; lower left corner (south-west); in 1/10 min, or 18 MSBs of addressed station ID 2 ($\pm 180^\circ$, East = positive, West = negative)
Latitude 2, (or 12 LSBs of addressed station ID 2)	17	Latitude of area to which the assignment applies; lower left corner (south-west); in 1/10 min, or 12 LSBs of addressed station ID 2, followed by 5 zero bits ($\pm 90^\circ$, North = positive, South = negative)
Addressed or broadcast message indicator	1	0 = broadcast geographical area message = default; 1 = addressed message (to individual station(s))
Channel A bandwidth	1	0 = default (as specified by channel number); 1 = 12.5 kHz bandwidth
Channel B bandwidth	1	0 = default (as specified by channel number); 1 = 12.5 kHz bandwidth
Transitional zone size	3	The transitional zone size in nautical miles should be calculated by adding 1 to this parameter value. The default parameter value should be 4, which translates to 5 nautical miles.
Spare	23	Not used. Should be set to zero
Total number of bits	168	

Channel Management Area Operations

The area registration can contain 8 different area data at maximum. In the fully-registered state containing 8 different data, if a new area setting is requested by a base station, the older area data is deleted in chronological order to accept a new registration.

If a new designated area includes an area coinciding with the registered area, that area is once deleted and registered as a part of the new area.

The existing area should be deleted in the following cases:

- When the registered area is now at a distance of 500 nm or farther from the own ship location.
- When a time period of 5 weeks or longer has elapsed from the date of registration.

For example, if an unauthorized channel, such as CH70, 1070, 2070, 1470, or 2470, is requested, both channels can operate in the reception mode of the international channel. When the channel switches to an international channel by request of an abnormal channel, the Tx/Rx Mode designated by Message 23 should not be observed until a correct channel is specified by Message 22 or DSC.

If a channel change occurs due to the event where the own ship enters into a new region or the transitional zone, transmissions are prohibited for 1 minute.

AP3.4.2 Assigned Area

This is an area designated by Message 23 transmitted from a base station. When the own ship stays in this area, the Assigned Mode becomes effective and the transmission rate specified in the Message 18 and the Tx/Rx Mode are observed during operation.

1. Only one Assigned area is allowed to be registered. The Assigned command is effective only for a short time period of 4 to 8 minutes and periodically invoked from a base station.
To define the Assigned area, the following conditions should be fully met.
 - 1) The own ship should stay in the area designated in the Message 23.
 - 2) The values specified in "Station Type" are identical between this device and the Message 23.
 - 0 = All types of mobile units (default)
 - 2 = All types of Class B mobile stations
 - 5 = Class B "CS" shipborne mobile stations (For FA-50, predefined in the program.)
 - 3) The set value in "Ship type" and the value in "Type of Ship" specified in the Message 23 are identical.
 - 4) In the Message 23, "Quiet Time" is specified with "0".
 - 5) In the Message 23, the value of L/L is correctly set.
 - 6) The own ship does not stay in the transitional zone in the channel management area.
2. The Assigned area can be deleted in the following cases:
 - 1) When a timeout occurs (about 4 to 8 min) in the Assigned Mode,
 - 2) When the own ship goes out of the Assigned area, and
 - 3) When a new Assigned area is accepted.
3. Operation modes in the Assigned area in the transitional zone are described below:
 - 1) When the own ship stays in the area belongs to both the Assigned area and the transitional zone, the Autonomous Mode is active during operation.
 - 2) When the own ship has gone out of the transitional zone and the Assigned area with no timeout issued is registered in the database, the Assigned Mode becomes active.
 - 3) While the own ship stays in the transitional zone, if a condition for deleting the Assigned area is met, its area data shall be deleted from the database.
 - 4) In the Assigned area, unlike the channel management area, a concept of transitional zone is not introduced.
 - 5) During a stay in the transitional zone, the Assigned area data can be shown on the WEB screen.
 - 6) Despite during a stay in the transitional zone, the Assigned area data can be shown on PC-MKD (FAISPC).
4. The Assigned area data is not backed up. At power off, the area data shall be deleted.

5. To accept the Assigned area, the following conditions must be met:
 - 1) Dimensions in height and width of the area should fall within a range of 1 to 200 nm.
 - 2) The latitudes should be less than 80 degrees north latitude and 80 degrees south latitude respectively.
 - 3) The own ship should stay in the area.

6. Priorities are assigned to the Assigned area and Quiet area as described below:
 - 1) Either the Assigned area or the Quiet area can be specified in one Message 23 so that both areas cannot be specified at a time.
 - 2) The Quiet area is given a higher priority than the Assigned area.

AP3.4.3 Quiet Area

This is an area designated by Message 23 transmitted from a base station. When the own ship stays in this area, the Quiet Mode becomes effective and the periodic messages of Message 18 and Message 24 are not transmitted. As a response messages to Message 15, however, the Message 18 and Message 24 can be transmitted.

1. Only one Quiet area is allowed to be registered. To register the Quiet area, the following conditions must be met:
 - 1) The own ship should stay in the area designated in the Message 23.
 - 2) The values specified in "Station Type" are identical between this device and the Message 23.
 - 0 = All types of mobile units (default)
 - 2 = All types of Class B mobile stations
 - 5 = Class B "CS" shipborne mobile stations (For FA-50, predefined in the program.)
 - 3) The set value in "Ship type" and the value in "Type of Ship" specified in the Message 23 are identical.
 - 4) In the Message 23, "Quiet Time" is specified with a value between 1 to 15 min inclusive.
 - 5) In the Message 23, the value of L/L is correctly set.
 - 6) The own ship should stay outside of the transitional zone.
 - 7) The own ship should not operate in the Quiet Mode.
2. The Quiet area can be deleted in the following cases:
 - 1) When a timeout occurs in the Quiet Mode,
 - 2) When the own ship goes out of the Quiet area.Once the Quiet area is set, the area data shall not be deleted from the database until any deleting condition is met.
The Quiet area data is not backed up. At FA-50 power off, the area data shall be deleted.
3. Operation modes in the Quiet area in the transitional zone are described below:
 - 1) When the own ship stays in the area belongs to both the Quiet area and the transitional zone, any commands of the Quiet area are ignored during operation.
 - 2) When the own ship has gone out of the transitional zone and the Quiet area with no timeout issued is registered in the database, the Quiet Mode becomes active.
 - 3) While the own ship stays in the transitional zone, if a deleting condition in the Quiet area is met, the Assigned area data shall be deleted from the database.
 - 4) In the Quiet area, unlike the channel management area, a concept of transitional zone is not introduced.

Appendix 4. IEC61162 Sentences

AP4.1 List of IEC Sentences used in FA-30/50/150

Sentence		I/O	Description	FA-150	FA-30	FA-50
AI	ABK	O	Addressed and binary broadcast acknowledgement	Yes	Yes	Yes
*	ABM	I	Addressed Binary and safety related Message	Yes	Yes	Yes
AI	ACA	I	AIS Regional Channel Assignment Message	Yes	Yes	No
AI	ACA	O	AIS Regional Channel Assignment Message	Yes	Yes	Yes
AI	ACS	O	Additional information of ACA	Yes	Yes	Yes
*	ACK	I	Acknowledgement alarm	Yes	Yes	Yes
*	AIR	I	AIS Interrogation Request	Yes	Yes	Yes
*	AIQ	I	AIS Query	Yes	Yes	Yes
AI	ALR	O	Set alarm state	Yes	Yes	Yes
*	BBM	I	Broadcast Binary Message	Yes	Yes	Yes
*	DSE	I	Expanded Digital Selective Calling	No	Yes	Yes
*	DSC	I	Digital selective calling information	No	Yes	Yes
*	DTM	I	Datum reference	Yes	Yes	Yes
*	GBS	I	GNSS Satellite fault detection	Yes	Yes	Yes
*	GGA	I	Global positioning system fix data	Yes	Yes	Yes
*	GLL	I	Geographic position, latitude/longitude	Yes	Yes	Yes
*	GNS	I	GNSS fix data	Yes	Yes	Yes
*	HDT	I	Heading true	Yes	Yes	Yes
*	LRI	O	Long Range Interrogation	Yes	No	No
*	LRF	O	Long Range Function	Yes	No	No
*	LR1	O	Long Range Reply with destination for function request "A"	Yes	No	No
*	LR2	O	Long Range Reply with destination for function request "B, C, E and F"	Yes	No	No
*	LR3	O	Long Range Reply with destination for function request "I, O, P, U and W"	Yes	No	No
*	OSD	I	Own ship data	Yes	Yes	Yes
*	RMC	I	Recommended minimum specific GNSS data	Yes	Yes	Yes
*	ROT	I	Rate of turn	Yes	No	No
*	SSD	I	Ship Static Data	Yes	No	Yes
AI	TXT	O	Text transmission	Yes	No	Yes
*	VBW	I	Dual ground/water speed	Yes	Yes	Yes
AI	VDM	O	VHF Data Link Message	Yes	Yes	Yes
AI	VDO	O	VHF Data Link Own-vessel message	Yes	Yes	Yes
*	VSD	I	Voyage Static Data	Yes	No	Yes
*	VTG	I	Course over ground and ground speed	Yes	Yes	Yes
*	ZDA	I	Time and date	No	Yes	No ^(note)

Note:

ZDA uses the data derived from the built-in GPS, the external GPS are not used.

AP4.2 Handling of Sentences

AP4.2.1 Overview

1. Handling of messages

Message	FA-30	FA-50	FA-150	Sentence used
6: Addressed Binary Message	No	No	Yes	ABM
12: Safety Related Addressed Message	No	No	Yes	BBM
8: Binary Broadcast Message	No	No	Yes	ABM
14: Safety Related Broadcast Message	No	Yes	Yes	BBM
15: Interrogation	No	No	Yes	ALR

Note:

In the cases marked with “No” in the table above, if the message specified is entered, the ABK sentence describing a disabled transmission is responded to FA30/50/150.

2. Comparisons on Input Data among FA-30/50 and FA-100/150

Item	FA-30	FA-50	FA-150
Sentence with no positioning time	Valid	Invalid	Invalid
GLL NMEA Ver-1.5 support	Invalid	Invalid	Invalid
Priority of time	1. Internal ZDA 2. Positioning time of RMC 3. UTC of MSG4/MSG11	1. Internal ZDA 2. Positioning time of RMC 3. UTC of MSG4/MSG11	1. External ZDA 2. Positioning time of RMC 3. UTC of MSG4/MSG11
Handling of sentences without checksum	Valid	Invalid	Invalid
Handling of talker name of HDT sentence	Talker ignored	Talker: invalid only for HC	Invalid only for HC

AP4.2.2 Input Data Processing

1. Processing at Reception Error

When a reception error occurs, the sentence in process becomes invalid.

2. Checking Method for Validity of Sentence

A sentence can be judged as invalid on the following status:

- When the checksum is incorrect
- When the latitude/longitude data contain a null code
- When the latitude data exceeds 90 degrees and the longitude data 180 degrees respectively
- When the heading data indicates a value other than 0-360 degrees.
- When the ship speed data indicates a value other than 0.0-99.99
- When a reception error occurs in the sentence
- When a sentence in invalid format is entered
- When found a value out of the range specified in the sentence details.

3. Handling of Checksum Field

A sentence with checksum should be checked for validity and, if an error is found, the sentence is judged as invalid. A sentence without checksum should be judged as invalid according to the initial setting and causes an error.

Also, from the setting in the PC-MKD menu, sentences without checksum can be made invalid.

4. Handling of Timeout

When an effective data has not been received for 5 seconds, a timeout occurs and no data exists.

- It takes 30 seconds for the L/L, SOG, and COG data to become effective, while 5 seconds to cause a timeout.
- HDG, GBS, and DTM become effective instantly at input and it takes 5 seconds for them to cause a timeout.
- ZDA becomes effective instantly at input and it takes 3 seconds for it to cause a timeout.

5. Priority of Talker

No priority of talker is defined.

GN, GP, GL, LC, and IN are used to determine a type of navigator.

Talkers except those mentioned above are identified as the default navigators.

6. Handling of Positioning Status

Depending on the Version of NMEA, sentences with no positioning status may not be accepted.

When a positioning status is contained, only VALID can be accepted. (With a VBW exception)

7. Priority Processing

RMC and GLL may or may not contain the positioning system mode depending on the Version of NMEA.

Depending on the presence or absence of the positioning system mode, priorities can be switched.

- Position (Pos): GNS (> GLL: with the Mode indicator) > GGA > RMC (with the Mode indicator) > GLL (without the Mode indicator) > RMC (without the Mode indicator)
- SOG, COG: VBW > RMC > VTG > OSD
Note: VBW is used only when HDT is valid.
- Heading: HDT > OSD
- RAIM flag: GBS

8. Number of decimal places in the sentence when converting to the storage data

- Position related: Discard the fifth decimal place
- Speed related: Discard the fourth decimal place
- Time related: Discard all digits to the right of the decimal point
- True heading related: Discard the fourth decimal place

9. Sentences of from LAN, COM port in Common Use

According to the setting, input/output sentences are switched.

(Refer to the section about port attributes and I/O sentences.)

10. Priorities of Ports

LAN port > COM port

11. Correlation between NMEA Ver. and Sentence

	Sentence	NMEA 1.5	NMEA 2.0	NMEA 3.0
Reference	DTM	No define	No define	Yes
POSITION	GNS	No define	No define	Yes
	GLL	No	Yes	Yes
	GGA	See Note	Yes	Yes
	RMC	Yes	Yes	Yes
SOG/COG	VBW	See Note	Yes	Yes
	VTG	See Note	Yes	Yes
	OSD	No define	Yes	Yes
	RMC	Yes	Yes	Yes
Heading	HDT	See Note	Yes	Yes
	OSD	No define	Yes	Yes
ROT	ROT	No define	Yes	Yes

Yes: Available No: Not available No define: Undefined in the standard

Note:

- 1) In NMEA183 Ver1.5, no checksum is attached.
- 2) In the specifications of FA-30/50, sentences without checksum cannot be used by default; however, setting [Sentence without Checksum] to “use” allows users to use the sentences without checksum.
- 3) Despite setting [Sentence without Checksum] to “use”, a sentence with checksum should be checked and, if the checksum is not correct, the sentence should be discarded as an invalid sentence.

AP4.2.3 Output Sentences

1. List of Output Sentences

Talker Format Type		I/O	Description	FA-30	FA-50	Transmission Period
AI	ABK	O	Addressed and binary broadcast acknowledgement	Yes	Yes	At each event
AI	ACA	O	AIS Regional Channel Assignment Message	Yes	Yes	At reception of regional area data At switching of regional area data
AI	ACS	O	Channel management information Source	Yes	Yes	At reception of regional area data At switching of regional area data
AI	ALR	O	Set alarm state	Yes	Yes	25 seconds during occurrence of an error, 2 minutes during normal operation
AI	TXT	O	Set alarm state	Yes	Yes	At a status change
AI	VDM	O	VHF Data-link Message	Yes	Yes	At VHF reception
AI	VDO	O	VHF Data-link Own-vessel message	Yes	Yes	1 second
PFEC	idfuc	I/O	Command for determining functions and detecting a communication error	Yes	Yes	At each event and every 15 seconds
PFEC	idatr	I/O	Command for switching port attributes	Yes	Yes	At each event

2. Comparisons on Output Data among FA-30/50 and FA-100/150

	FA-30	FA-50	FA-150
ABK	Yes	Yes	Yes
ACA	Yes	Yes	Yes
ACS	Yes	Yes	No
ALR	Yes	Yes	Yes
TXT	Yes	Yes	Yes
VDO	Yes	Yes	Yes
VDM	Yes	Yes	Yes
LRF	No	No	Yes
LRI	No	No	Yes
LR1	No	No	Yes
LR2	No	No	Yes
LR3	No	No	Yes

Yes: Output No: No output

	FA-30	FA-50	FA-150	
VDO (Actual VHF transmission)	No	MSG 13, 14, 19, 24	MSG 1, 2, 3, 5, 6, 7, 8, 11, 12, 13, 15	
MSG number of NULL VDO	(Note1) MSG 1 & 5 or 18 & 24	MSG18 MSG24	MSG 1 MSG 5	
(When MMSI undefined) NULL VDO output	No output (Note2)	No output	No output	
(When MMSI undefined) MMSI field of ACS	NULL output	NULL output	ACS not supported	MMSI of area editor
(When MMSI undefined) Message to other ships (Note3)	No output	No output	No output	
UTC field in ALR when UTC undefined	NULL output	NULL output	NULL output	Time of occurrence of alarm
UTC field in ACA when UTC undefined	NULL output	NULL output	(Note4)	Time of area switching Time of area addition
UTC field in ACS when UTC undefined	NULL output	NULL output	ACS not supported	

Note1: Switching by the menu.
(MSG.1 & 5 or MSG.18 & 24 or MSG. (1 & 5)/ (18/24 alternately))

Note2: In FA-30, normally, MMSI is not set so that the transmission of NULL VDO terminates.
To produce a NULL VDO output on FA-30, the MMSI dummy mode should be turned ON.
(Due to a connection to IF-1500AIS, the default on FA-30 is assumed to be an initial value of dummy MMSI of 999,999,000 to output NULL VDO.)
During the dummy mode, a VDM output containing a message to other ships is not produced.

Note3: Basically, a message to other ships is not outputted by VDM.
During the dummy mode, VDM outputs are not produced regardless of the value of dummy MMSI.

Note4: On FA-100/150, the following outputs, for example, are produced.

At normal transmission:

\$AIACA,0,3544.45,N,13535.22,E,3543.55,N,13534.33,E,8,8087,1,8088,1,0,1,M,
1,235959.00*34<CR><LF>

Information of international waters:

\$AIACA,0,,N,,E,,N,,E,8,2087,1,8088,1,,10,1,M,1,000000.00*34<CR><LF>

AP4.3 Sentence Description

ABK Addressed and binary broadcast acknowledgement

The ABK sentence is issued when a process initiated by the received ABM, AIR, or BBM sentence has completed or terminated.

This sentence provides information on whether ABM communication requested by either Message6 or Message12 of ITU-R M.1371 has been successfully completed or failed. The ABK process uses information received in Message7 and 13 of ITU-R M.1371.

When receiving Message7 or 13 of VHF data link or receiving a failure of Message6 or 12, the AIS unit transfers the ABK sentence to the external application.

This sentence is used to transfer the processes of AIR sentences (Message15 of ITU-R M.1371) and BBM sentences (Message8 and 14 of ITU-R M.1731) on the AIS unit to the external application.

The external application initiates an interrogation using an AIR sentence or communication using a BBM sentence.

The AIS unit issues an ABK sentence to transfer a result of the AIR or BBM communication process.

$$\text{\$--ABK, } \underbrace{\text{xxxxxxxxx}}_a, \underbrace{a}_{b}, \underbrace{x.x}_{c}, \underbrace{x}_{d}, \underbrace{x}_{e} *hh\langle\text{CR}\rangle\langle\text{LF}\rangle$$

- a: MMSI of the addressed destination AIS unit
- b: AIS channel of reception
- c: ITU-R M.1371 message ID
- d: Message Sequence Number
- e: Type of acknowledgement

ABM Addressed Binary and safety related Message

This sentence provides Message6 and 12 of ITU-R M.1371. The ABM provides a means for exchanging data by AIS to the external application.

The message data is defined solely by the application instead of AIS.

After receiving this sentence, the AIS starts broadcasting on the VHF data link with either Message6 or 12.

\$--ABM, x, x, x, xxxxxxxx, x, x.x, s--s, x*hh<CR><LF>
 a b c d e f g h

- a: Total number of sentences needed to transfer the message, 1 to 9
- b: Sentence number, 1 to 9
- c: Sequential Message identifier, 0 to 3
- d: The MMSI of destination AIS unit for the ITU-R M.1371 message
- e: AIS channel for broadcast of the radio message
- f: ITU-R M.1371 message ID (6 or 12)
- g: Encapsulated data
- h: Number of fill-bits, 0 to 5

ACK Acknowledgement alarm

This sentence is used as a receipt acknowledgement of the alarm status reported by a unit.

\$--ACK, xxx *hh<CR><LF>
 a

- a: Local alarm number(identifier)

AIR AIS Interrogation Request

This sentence supports Message15 of ITU-R M.1371.

It provides a means for initiating a request for a certain ITU-R M.1371 message from a distant AIS station or an AIS base station to the external application.

\$--AIR, xxxxxxxx, x.x, x, x.x, x, xxxxxxxx, x.x, x *hh<CR><LF>
 a b c d e f g h

- a: MMSI of interrogated station-1
- b: ITU-R M.1371 message requested from station-1 note)
- c: message sub-section (Reserved for future use)
- d: number of second message from station-1 note)
- e: message sub-section (Reserved for future use)
- f: MMIS interrogated station-2
- g: number of message requested from station-2note)
- h: message sub-section (Reserved for future use)

Note)

- From a distant mobile AIS station
 - Message3: Position report
 - Message5: Ship static and voyage related data
 - Message9: Standard SAR aircraft position report
 - Message18: Standard class B equipment position report
 - Message19: Extended class B equipment position report
 - Message21: Aids-to-Navigation report
- From a distant base AIS station
 - Message4: Base station report
 - Message17: GNSS broadcast binary message
 - Message20: Data link management message
 - Message22: Channel management

ALR Set alarm state

This sentence is used to report an alarm condition and an alarm acknowledge state of a unit.

\$--ALR, hhmmss.ss, xxx, A, A, c--c *hh<CR><LF>
 a b c d e

- a: Time of alarm condition change, UTC
- b: Local alarm number(identifier) [identification number of alarm source]
- c: Alarm condition (A= threshold exceeded, V=not exceeded)
- d: Alarm's acknowledge state (A=acknowledged, V=unacknowledged)
- e: Alarm's description text

BBM Broadcast Binary Message

This sentence supports issuing ITU-R M.1371 Message8: Binary broadcast message or Message14: Safety related broadcast message. After receiving this sentence, the AIS starts VHF broadcast communication of either Message8 or 14 within 4 seconds.

The success or failure of this broadcast is determined by both an ABK sentence and the process supporting the issue of the ABK sentence. This AIS should be restricted the use of slot and frame, as well as the amount of data summarized to be separately sent to them. If a message has the length of 5 slots or more, or AIS broadcast communication has transmitted 20 RATDMA slots or more at the time of the current frame, the AIS returns a receipt notice saying "Message transfer has failed" by ABK.

\$--BBM, x, x, x, x, x.x, s--s, x *hh<CR><LF>
 a b c d e f g

- a: Total number of sentences needed to transfer the message, 1 to 9
- b: Sentence number, 1 to 9
- c: Sequential message identifier, 0 to 9
- d: AIS channel for broadcast of the radio message
- e: ITU-R M.1371 message ID, 8 or 14
- f: Encapsulated data
 - Message8: binary data parameter
 - Message14: Safety related text parameter
- g: Number of fill-bits, 0 to 5

DTM Datum reference

This sentence provides a local datum and offset data from the reference standard point.

\$--DTM, ccc, a, x.x, a, x.x, a, x.x, ccc *hh<CR><LF>
 a b c d e f

a: Local datum

WGS84=W84

WGS72=W72

SGS85=S85,

PE90=P90

User define=999

IHO datum code

b: Local datum subdivision code

c: Lat offset, min, N/S

d: Lon offset, min, E/W

e: Altitude offset, m

f: Reference datum

WGS84=W84

WGS72=W72

SGS85=S85

PE90=P90

GBS GNSS Satellite fault detection

This message is used to support RAIM (Receiver Autonomous Integrity Monitoring).

\$--GBS, hhmmss.ss, x.x, x.x, x.x, xx, x.x, x.x, x.x *hh<CR><LF>
 a b c d e f g h

a: UTC time of the GGA or GNS fix associated with this sentence

b: Expected error in latitude

c: Expected error in longitude

b: Expected error in altitude

e: ID number of most likely failed satellite

f: Probability of missed detection for most likely failed satellite

g: Estimate of bias on most likely failed satellite

h: Standard deviation of bias estimate

GGA Global positioning system fix data

This sentence provides GPS positioning data, time, and position data.

```

$--GGA, hhmmss.ss, lll.ll, a, yyyyy.yy, a, , x,
          a          b          c          d
          xx, x.x, x.x, M, x.x, M, x.x, xxxx *hh<CR><LF>
          e   f   g   h   i   j   k   l

```

a: UTC of position

b: Latitude, N/S

c: Longitude, E/W

d: GPS quality indicator

0=fix not available or invalid,

1=GPS SPS mode, fix valid,

2=differential GPS, SPS mode, fix valid,

3=GPS PPS mode, fix valid,

4=Real Time kinematic. Satellite system used in RTK mode with fixed integers

5=Float RTK. Satellite system used in RTK mode with floating integers,

6=Dead reckoning mode,

7=Manual input mode,

8=Simulator mode

e: Number of satellites in use, 00-12, may be different from the number in view

f: Horizontal dilution of precision

g: Antenna altitude above/below mean sea level (geoid)

h: Units of antenna altitude, m

i: Geoidal separation (difference between the WGC-84)

j: Units of geoidal separation, m

k: Age of differential GPS data

l: Differential reference station ID, 0000-1023

GLL Geographic position, latitude/longitude

This sentence provides latitude/longitude, positioning time, and status of the ship.

\$--GLL, lll.ll, a, yyyyy.yy, a, hhmmss.ss, A, a *hh<CR><LF>
 a b c d e

a: Latitude, N/S

b: Longitude, E/W

c: UTC of position

d: Status

A=data valid

V=data invalid

e: Mode indicator

A=Autonomous

M=Manual input

E=Dead reckoning

D=differential

S=Simulator

N=Data not valid

GNS GNSS fix data

This sentence provides positioning data obtained by a combination of GNSS (GPS/GLONASS/Satellite system in the future) or individually by them.

\$--GNS, hhmmss.ss, lll.ll, a, yyyyy.yy, a, c--c,
 a b c d
xx, x.x, x.x, x.x, x.x, x.x *hh<CR><LF>
 e f g h i j

a: UTC of position

b: Latitude, N/S

c: Longitude, E/W

d: Mode indicator 1st char.=GPS, 2nd=GLONASS, 3rd=other satellite system

N=No fix

F=Float RTK

A=Autonomous

E=Dead reckoning mode

D=Differential

M=Manual input mode

P=Precise

S=Simulator mode

R=Real time Kinematic

e: Total number of satellites in use, 00-99

f: HDOP

g: Antenna altitude, m, re: mean-sea-level(geoid)

h: Geoidal separation, m

i: Age of differential data

j: Differential reference station ID

HDT Heading true

This sentence provides true heading data.

\$--HDT, x.x, T *hh<CR><LF>
 a

a: Heading, degree true

OSD Own ship data

This sentence provides the data including heading, course, speed, as well as speed and direction of a tidal current.

\$--OSD, x.x, A, x.x, a, x.x, a, x.x, x.x, a *hh<CR><LF>
 a b c d e f g h i

- a: Heading, degrees true
- b: Heading status A=data valid, V=data invalid
- c: Vessel course, degrees true
- d: Course reference, B/M/W/R/P
 - B=bottom tracking log
 - M=manually entered
 - W=water referenced
 - R=radar tracking (of fixed target)
 - P=positioning system ground reference
- e: Vessel speed
- f: Speed reference, B/M/W/R/P
- g: Vessel set, degrees true
- h: Vessel drift(speed)
- i: Speed unit (km/h, Knots, miles/h)

RMC Recommended minimum specific GNSS data

This sentence provides the data including speed, course, position, date, and time supplied by GNSS.

```

$--RMC, hhmmss.ss, A, llll.ll, a, yyyyy.yy, a, x.x,
      a         b     c         d     e
      x.x, xxxxxx, x.x, a, a *hh<CR><LF>
      f         g         h     i
    
```

- a: UTC of position fix
- b: Status (A=data valid V=navigation receiver warning)
- c: Latitude, N/S
- d: Longitude, E/W
- e: Speed over ground, knots
- f: Course over ground, degrees true
- g: Date: dd/mm/yy
- h: Magnetic variation, degrees, E/W
- i: Mode indicator

A=Autonomous mode	M=Manual input mode
D=Differential mode	S=Simulator mode
E=dead reckoning mode	N=Data not valid

SSD Ship Static Data

This sentence is used to specify the static parameters of AIS.

```

$--SSD, c--c, c--c, xxx, xxx, xx, xx, c, aa *hh<CR><LF>
      a         b     c     d     e     f     g     h
    
```

- a: Ship's Call Sign, 1 to 7 characters
- b: Ship's name, 1 to 20 characters
- c: Pos. ref., "A", distance from bow, 0 to 511 meters
- d: Pos. ref., "B", distance from stern, 0 to 511 meters
- e: Pos. ref., "C", distance from port beam, 0 to 63 meters
- f: Pos. ref., "D", distance from starboard beam, 0 to 63 meters
- g: DTE indicator flag

0=Keyboard and display are a standard configuration, and communication is supported.
1=Keyboard and display are either unknown or unable to support communication.
- h: Source identifier

TXT Text transmission

This sentence is used to transmit a text message.

\$--TXT, xx, xx, xx, c--c *hh<CR><LF>
 a b c d

- a: Total number of messages, 01 to 99
- b: Message number, 01 to 99
- c: Text identifier
- d: Text message

VBW Dual ground/water speed

This sentence provides the data of speed through the water and speed over ground.

\$--VBW, x.x, x.x, A, x.x, x.x, A, x.x, A, x.x, A *hh<CR><LF>
 a b c d e f g h i j

- a: Longitudinal water speed, knots
- b: Transverse water speed, knots
- c: Status: water speed (A=data valid, V=data invalid)
- d: Longitudinal ground speed, knots
- e: Transverse ground speed, knots
- f: Status: ground speed (A=data valid, V=data invalid)
- g: Stern transverse water speed, knots
- h: Status: stern water speed (A=data valid, V=data invalid)
- i: Stern transverse ground speed, knots
- j: Status: stern ground speed (A=data valid, V=data invalid)

VDM VHF Data Link Message

This sentence is used to transfer all contents of the AIS message packets that are defined by ITU-R M.1371 and received over the VHF data link (VDL) using a 6 bit field type. This structure is provided to transfer a long binary message using multiple sentences.

$$\text{\$--VDM, } \underset{a}{\underline{x}}, \underset{b}{\underline{x}}, \underset{c}{\underline{x}}, \underset{d}{\underline{a}}, \underset{e}{\underline{s---s}}, \underset{f}{\underline{x}} *hh<CR><LF>$$

- a: Total number of sentences needed to transfer the message, 1 to 9
- b: Sentence number, 1 to 9
- c: Sequential message identifier, 0 to 9
- d: AIS Channel, "A" or "B"
- e: Encapsulated ITU-R M.1371 radio message
- f: Number of fill-bits, 0 to 5

VDO VHF Data Link Own-vessel message

This sentence is used to provide information collected for AIS broadcast communication. To summarize the data, a 6 bit field type is used. This sentence has the same structure as VDM.

$$\text{\$--VDO, } \underset{a}{\underline{x}}, \underset{b}{\underline{x}}, \underset{c}{\underline{x}}, \underset{d}{\underline{a}}, \underset{e}{\underline{s---s}}, \underset{f}{\underline{x}} *hh<CR><LF>$$

- a: Total number of sentences needed to transfer the message, 1 to 9
- b: Sentence number, 1 to 9
- c: Sequential message identifier, 0 to 9
- d: AIS Channel, "A" or "B"
- e: Encapsulated ITU-R M.1371 radio message
- f: Number of fill-bits, 0 to 5

VSD Voyage Static Data

This sentence is used to input information about a voyage. This information changes on rare occasion during a voyage.

\$--VSD, x.x, x.x, x.x, c--c, hhmmss.ss, xx, xx, x.x, x.x *hh<CR><LF>
 a b c d e f g h i

- a: Type of ship and cargo category, 0 to 255
- b: Maximum present static draught, 0 to 25.5 meter
- c: Persons on-board, 0 to 8191
- d: Destination, 1-20 characters
- e: Est. UTC of destination arrival
- f: Est. day of arrival at destination, 00 to 31 (UTC)
- g: Est. month of arrival at destination, 00 to 12 (UTC)
- h: Navigational status, 0 to 15
 ex) 0=under way using engine 1=at anchor
 2=not under command ----etc----
- i: Regional application flags, 0 to 15

VTG Course over ground and ground speed

This sentence provides the data of speed over ground and course over ground.

\$--VTG, x.x, T, x.x, M, x.x, N, x.x, K, a *hh<CR><LF>
 a b c d e

- a: Course over ground, degrees true
- b: Course over ground, degrees magnetic
- c: Speed over ground, knot
- d: Speed over ground, km/m
- e: Mode indicator
 A=Autonomous mode M= Manual input mode
 D=Differential mode S= Simulator mode
 E=Dead reckoning mode N=Data not valid

カバー組み
COVER ASSEMBLY
FA-50
(001-034-490)

パネルハニマク
PANEL LABEL
05-097-2527-0

カバー
COVER
02-158-1004-1

メインシールド組み
MAIN SHIELD ASSEMBLY
FA-50
(001-034-480)

ドコウジク4
SHAFT 4
05-097-2523-1

ドコウジクオサエタ
SHAFT FIXING PLATE
05-097-2522-1

ケイコラベル(2)
WARNING LABEL(2)
03-129-1001-3

メインシールド
MAIN SHIELD
05-097-2521-1

シールドケース2
SHIELD CASE 2
05-096-2521-1
(100-338-381-10)

ハニンドコネ
BINDING HEAD SCREW
M3X6 SUS304
(000-162-664-10)

シールドフォーム
SHIELDED FORM
81TS 5-5.5 *1.0M*

MAIN&TXプリント
PRINTED CIRCUIT BOARD
05P0814(LF)
(001-034-470)

RX2プリント
PRINTED CIRCUIT BOARD
05P0808B(LF)
(001-015-630)

RX1プリント
PRINTED CIRCUIT BOARD
05P0808A(LF)
(001-015-620)

PWRプリント
PRINTED CIRCUIT BOARD
05P0809(LF)
(001-034-460)

ミニピンミニ(1)
MINI PIN ASSY(1)
L-110
(000-165-839-10)

TRオサエタ
TR FIXING PLATE
05-097-2515-1
(100-343-661-10)

ミニピンミニ(1)
MINI PIN ASSY(1)
L-70
(000-165-834-10)

ケーブル(クミン)
CABLE ASSEMBLY
05S9462-2
(000-165-389-12)

キャップスペース
CAP SPACER
CS-10S
(000-164-960-10)

シャーシ
CHASSIS
05-097-2511-1
(100-343-621-10)

ナニヘニムスB
WASHER HEAD SCREW *B*
M3X8 C2700W MBNI2
(000-163-190-10)

ナニヘニムスB
WASHER HEAD SCREW *B*
M4X12 C2700W MBNI2
(000-163-192-10)

ナニヘニタイトウサツキ
PAN HEAD P-TIGHT SCREW
3X8 SWRM10
(000-158-071-10)

ベース
BASE CHASSIS
05-097-2512-1
(100-343-631-10)

ベース
BASE
02-158-1003-1
(100-337-561-10)

ヨビン
SPARE PARTS
SP05-05801

ヒューズ GLASS TUBE FUSE FGMB 125V 4A PBF (000-157-482-10)	2
---	---

コウザイ
INSTALLATION MATERIALS
CP05-11401

トラスツツピンネジ1シ SELF TAPPING SCREW 4X20 SUS304 (000-158-850-10)	4
--	---

フゾク
ACCESSORIES
FP05-06110
(000-011-840)

AISヒョウシツソフトCD AIS VIEWER FAISPC-MX50	1
--	---

フゾク
ACCESSORIES
FP05-06100
(000-013-180)

AISヒョウシツソフトCD AIS DISPLAY SOFTWARE CD-ROM FAISPC-B/OM-44431-C	1
---	---

ブンハイハコ
DISTRIBUTION BOX
DB-1
(000-054-087)

ケールシート
SILICON RUBBER
05-097-2516-0
(100-343-670-10)

グロメット
GROMMET
C-30-NG-79-D-UL
(000-165-420-10)

ナニヘニムスA
WASHER HEAD SCREW *A*
M3X10 C2700W MBNI2
(000-163-157-10)

ナニヘニムスB
WASHER HEAD SCREW *B*
M3X12 C2700W MBNI2
(000-163-184-10)

プツツング
STRAIN RELIEF BUSHING
SR-6P-4
(000-165-933-10)

GPS TBプリント
PRINTED CIRCUIT BOARD
24P0043A
(001-041-520)

ケーブル(クミン)
CABLE ASSEMBLY
MJ145-TMP-1.5D-L090
(000-164-699-10)

コネクタパネル組み
CONNECTOR PANEL ASSEMBLY
FA-50
(001-034-500)

コネクタパネル
CONNECTOR PANEL
05-097-2513-2

パネルシート
PANEL SHEET
05-097-2514-1

MODEL	FA-50				
APPROVED	CHECKED	DRAWN	UNIT	FA-50	船舶識別装置
4 Aug2008	4 Aug2008	4 Aug2008			CLASS B AIS TRANSPONDER
Y.Kamba	T.Yoshida	S.Kubota	DWG.NO.	C4442-E01-A	

Contents of Drawings

Name	Type	Dwg. No.	Page
Interconnection diagram	FA-50	C4442-C01	S-1
FA-50 Schematic diagram	FA-50	C4442-K01	S-2
MAIN&Tx board	05P0814 1/9 (I/O & CONNECTOR)	C4442-K02	S-3
	05P0814 2/9 (LAN & GPS)	C4442-K03	S-4
	05P0814 3/9 (CPU & MEMORY)	C4442-K04	S-5
	05P0814 4/9 (FPGA1)	C4442-K05	S-6
	05P0814 5/9 (FPGA2 & DDS)	C4442-K06	S-7
	05P0814 6/9 (CLK & DDS)	C4442-K07	S-8
	05P0814 7/9 (TX PART)	C4442-K08	S-9
	05P0814 8/9 (CODEC)	C4442-K09	S-10
	05P0814 9/9 (POWER)	C4442-K10	S-11
POWER board	05P0809	C4442-K11	S-12
IF-1500AIS Interconnection diagram	IF-1500AIS	C4435-C01	S-13
Distributor	DB-1	C4417-K15	S-14
AC/DC power supply	PR-240CE	C5003-K04	S-15

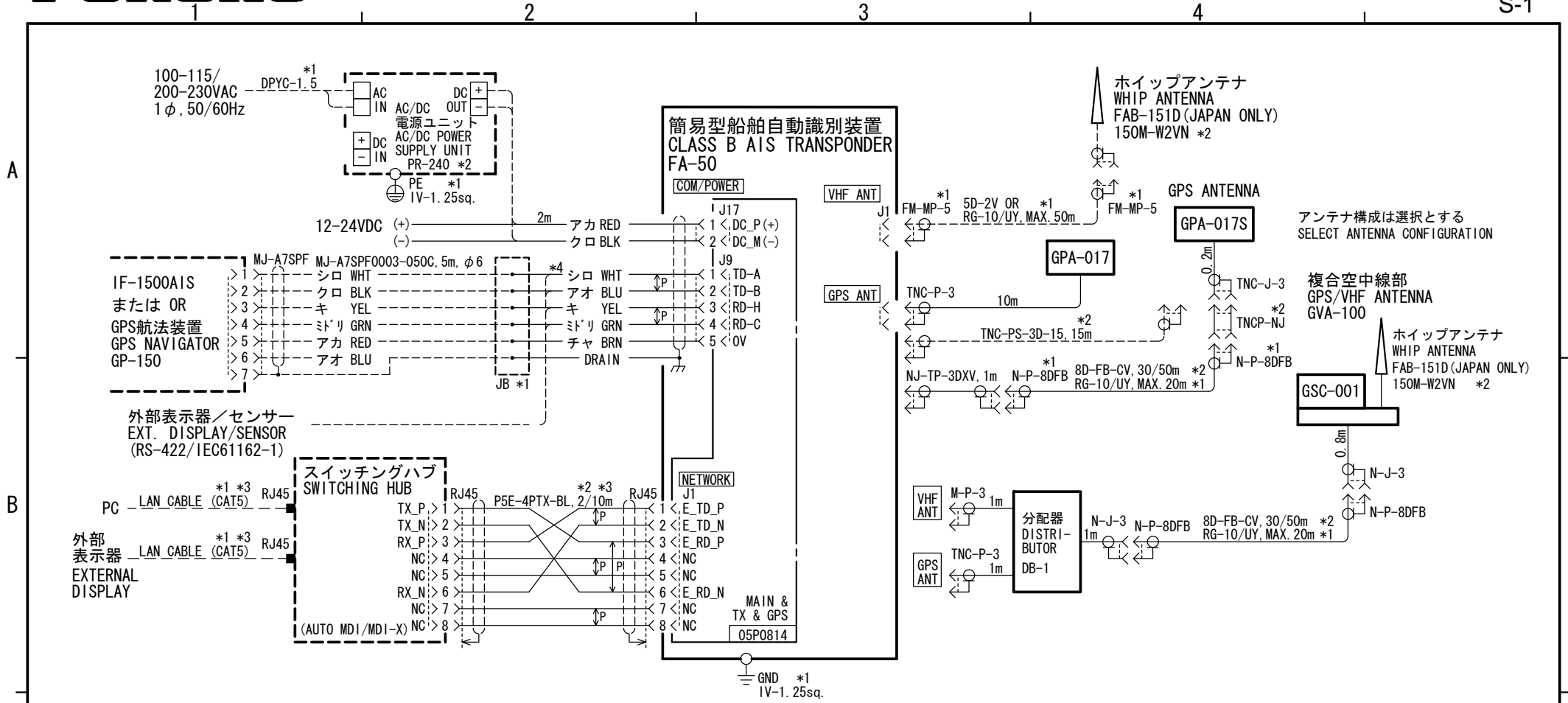

注記

- *1) 造船所手配。
- *2) オプション。
- *3) Auto MDI/MDI-X対応でないHUBのときは、ストレートケーブルを使用する。
- *4) COMラインを使用しないときは、芯線がショートしないようテープで絶縁する。

NOTE

- *1: SHIPYARD SUPPLY.
- *2: OPTION.
- *3: USE STRAIGHT LAN CABLE WHEN A HUB W/O AUTO MDI/MDI-X FUNCTION IS USED.
- *4: IF COM LINES ARE NOT USED, TAPE THEM TO PREVENT SHORT-CIRCUIT.

DRAWN	Jan. 8 '08 T. YAMASAKI	TYPE	FA-50
CHECKED	Jan. 9 '08 T. TAKENO	名称	簡易型船舶自動識別装置
APPROVED	Jan. 18 '08 R. Esumi		相互結線図
SCALE	MASS kg	NAME	CLASS B AIS TRANSPONDER
DWG. No.	C4442-C01- B	REF. No.	05-097-2002-0
			INTERCONNECTION DIAGRAM

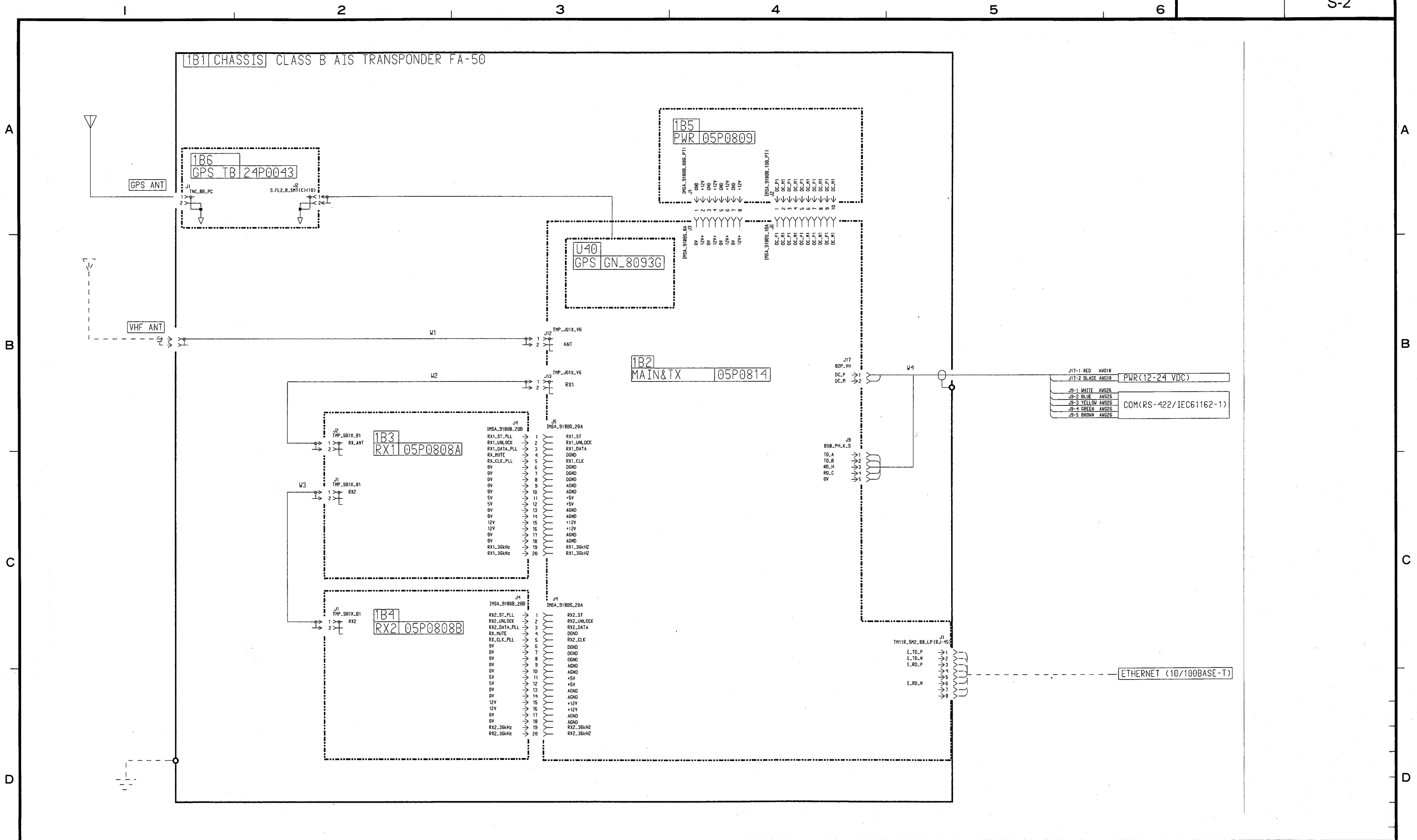

DRAWN 09/06/05 T. YAMASAKI	TYPE FA-50
CHECKED <i>Jun 8 '09 T. Takano</i>	名称 簡易型船舶自動識別装置
APPROVED <i>Jun 9 '09 R. Elm</i>	回路図
SCALE MASS	MODEL BLOCK No. NAME FA-50 CLASS B AIS TRANSPONDER
Dwg No. C4442-K01-A	REF. No. 05-097-2002-0 SCHEMATIC DIAGRAM

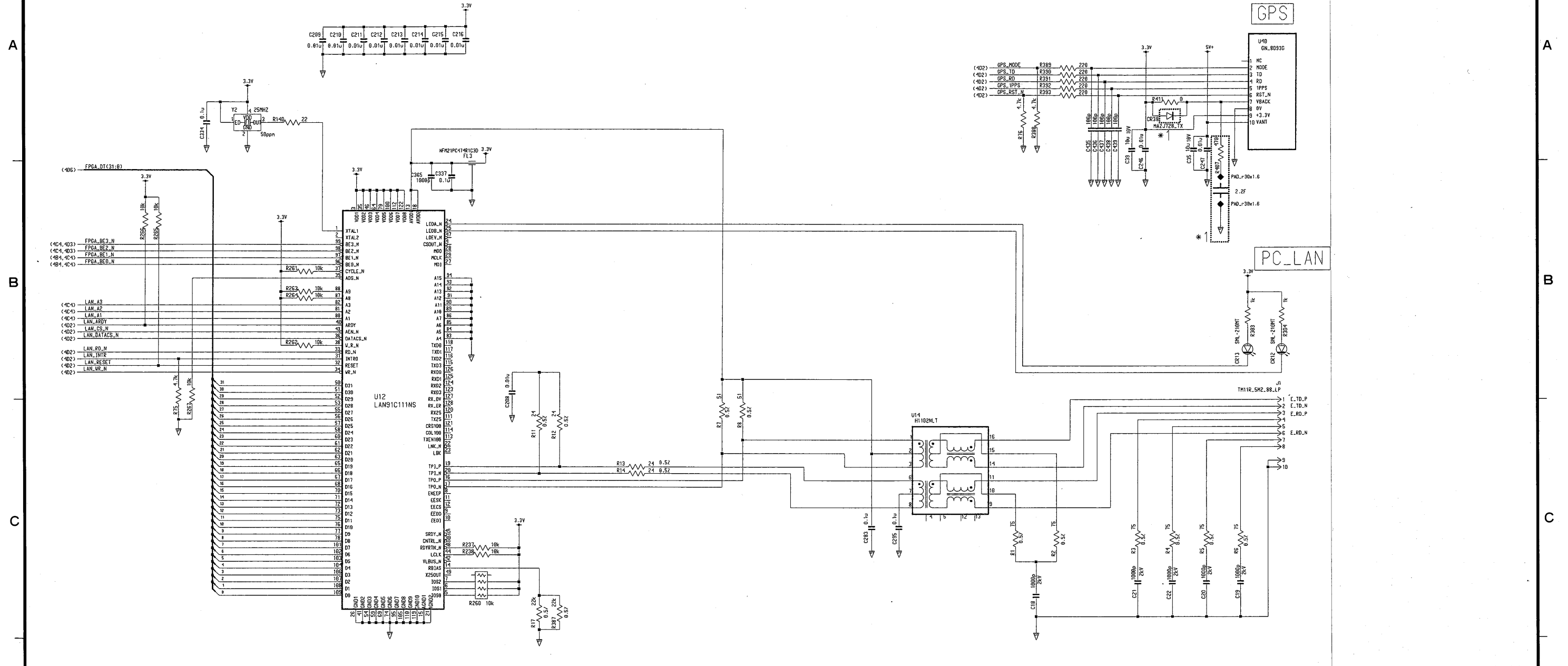

Note
*1: pattern only

DRAWN 09/06/05 T. YAMASAKI	TYPE 05P0814 (2/9)
CHECKED Jan. 8 '09 T. Takeo	名称 MAIN&TX基板
APPROVED Jan. 9 '09 M. Elmi	回路図
SCALE MASS	NAME MAIN&TX PCB
Dwg No. C4442-K03- A	REF. No. 05-097-2102-0
	SCHEMATIC DIAGRAM

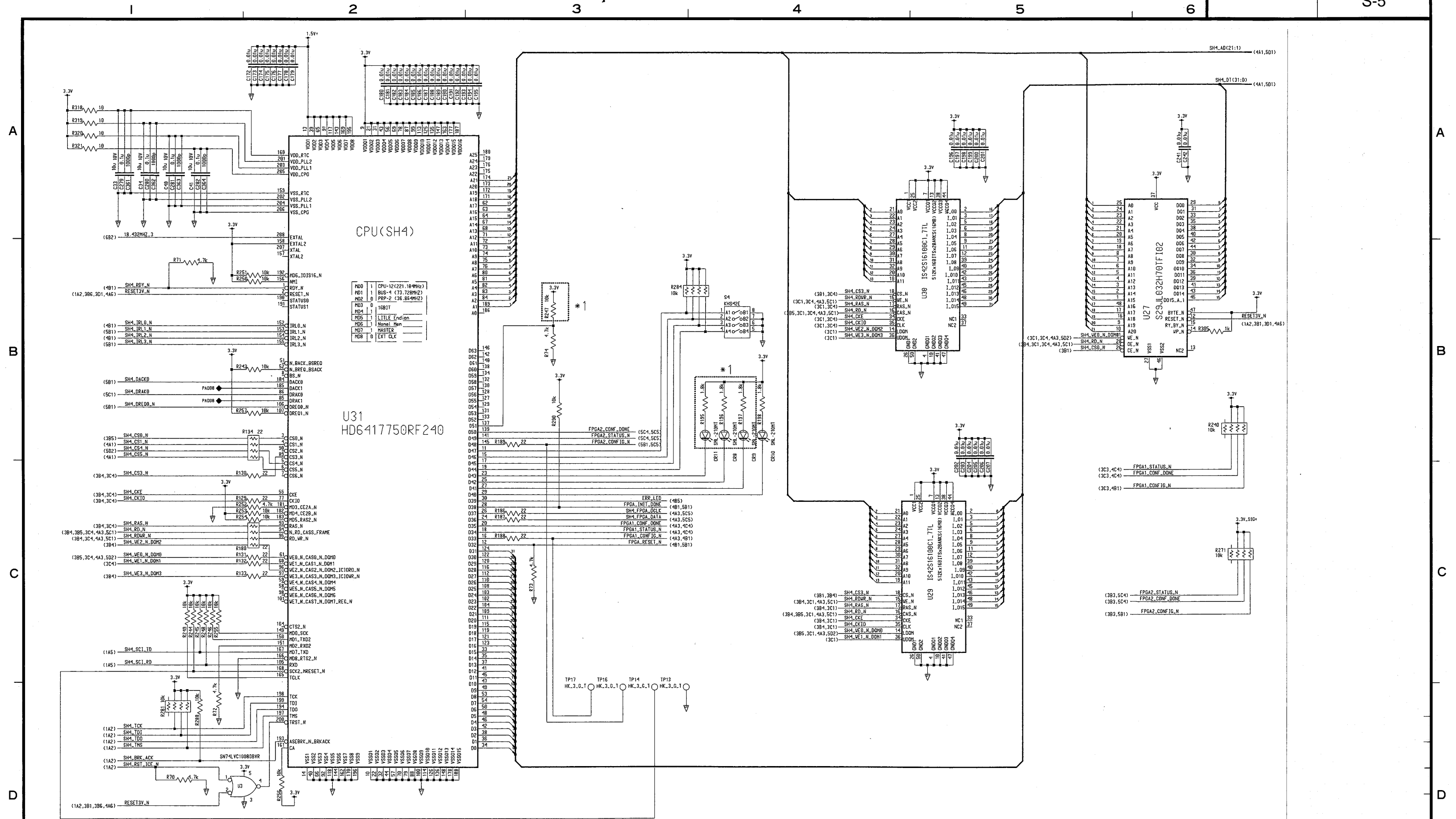

Note
*1: pattern only

DRAWN 09/06/05 T. YAMASAKI CHECKED <i>Dem Siof T. Takeo</i> APPROVED <i>Jun 09/09 M. Elm</i> SCALE MASS	TYPE 05P0814 (3/9) 名称 MAIN&TX基板 回路図 NAME MAIN&TX PCB SCHEMATIC DIAGRAM
Dwg No. C4442-K04- A	REF. No. 05-097-2103-0

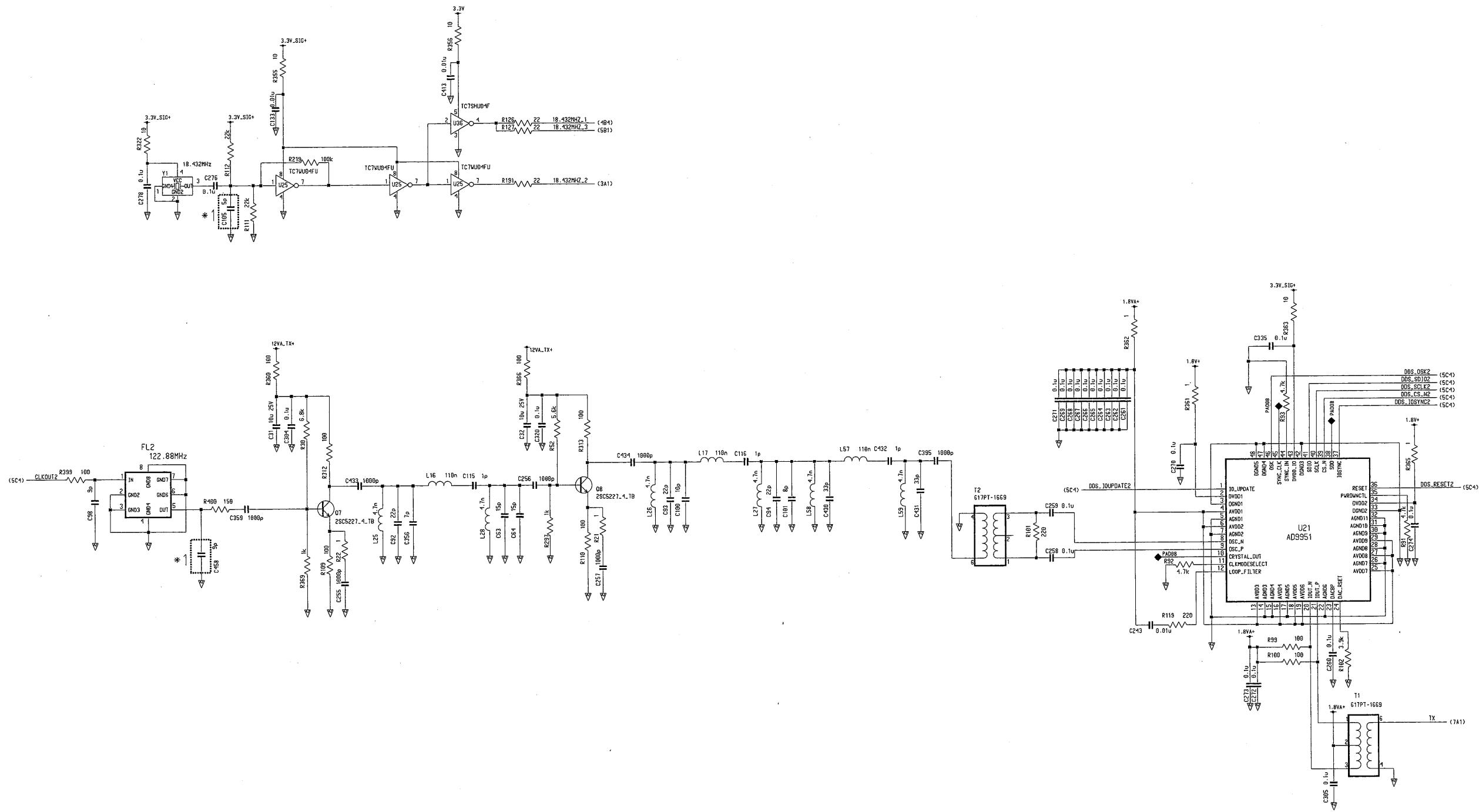

Note
*1: pattern only

DRAWN 09/06/05 T. YAMASAKI		TYPE 05P0814 (6/9)
CHECKED <i>Jan 8'09 T. Takano</i>		名称 MAIN&TX基板
APPROVED <i>Jan 9'09 R. Elmi</i>	FA-50 1B 2	回路図
SCALE MASS	MODEL BLOCK No.	NAME MAIN&TX PCB
Dwg No. C4442-K07- A	REF. No. 05-097-2106-0	SCHEMATIC DIAGRAM

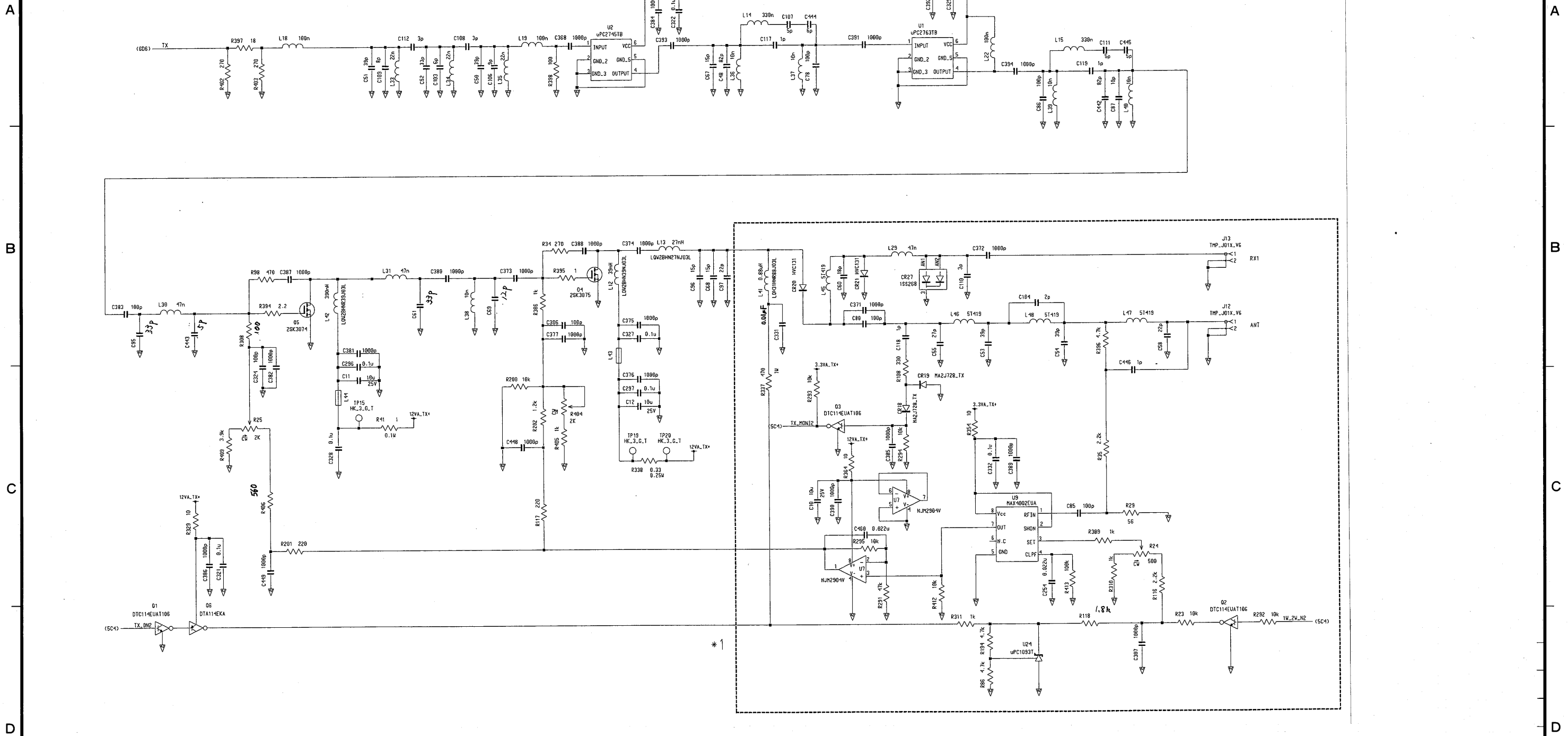

Note
*1: In Shield Case

DRAWN 09/06/05 T. YAMASAKI CHECKED APPROVED SCALE MASS	TYPE 05P0814 (7/9) 名称 MAIN&TX基板 回路图 NAME MAIN&TX PCB SCHEMATIC DIAGRAM
Dwg No. C4442-K08-A REF. No. 05-097-2107-2	FA-50 MODEL 1B 2 BLOCK No. NAME SCHEMATIC DIAGRAM

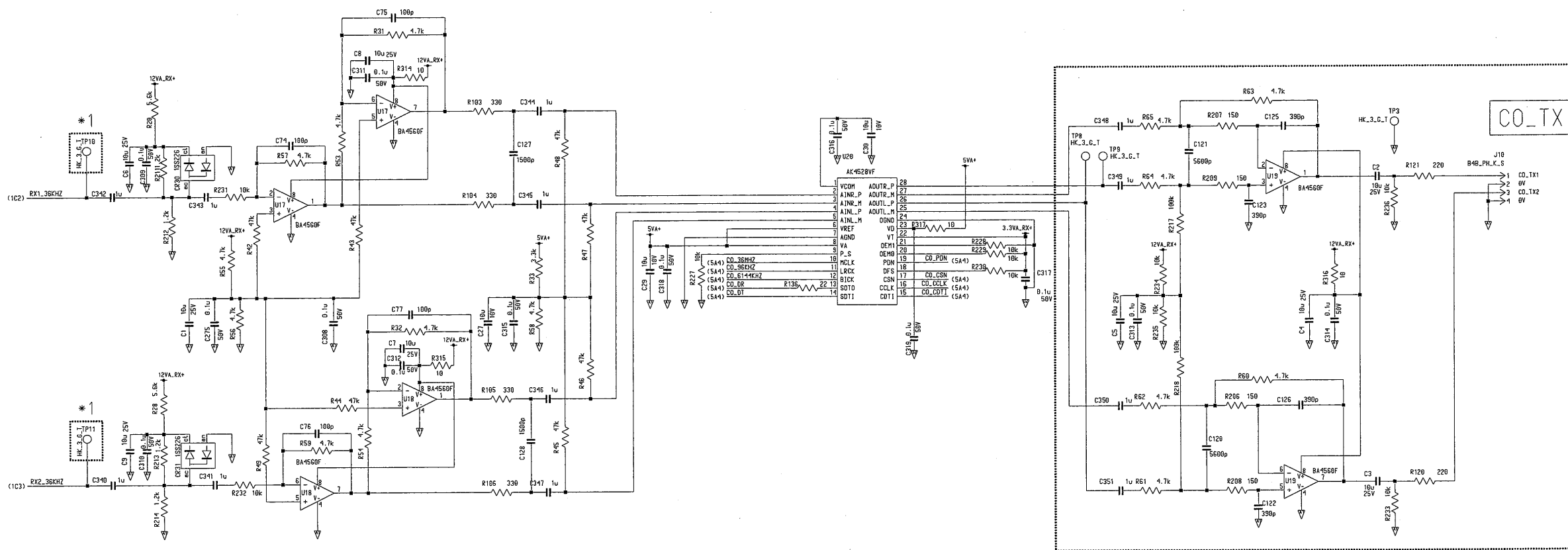

Note
*1: pattern only

DRAWN 09/06/05 T. YAMASAKI CHECKED <i>T. Takano</i> APPROVED <i>Sun 9/09 M. Fuji</i> SCALE MASS	TYPE 05P0814 (8/9) 名称 MAIN&TX基板 回路図 NAME MAIN&TX PCB SCHEMATIC DIAGRAM
FA-50 MODEL C4442-K09- A	1B 2 BLOCK No. REF. No. 05-097-2108-0

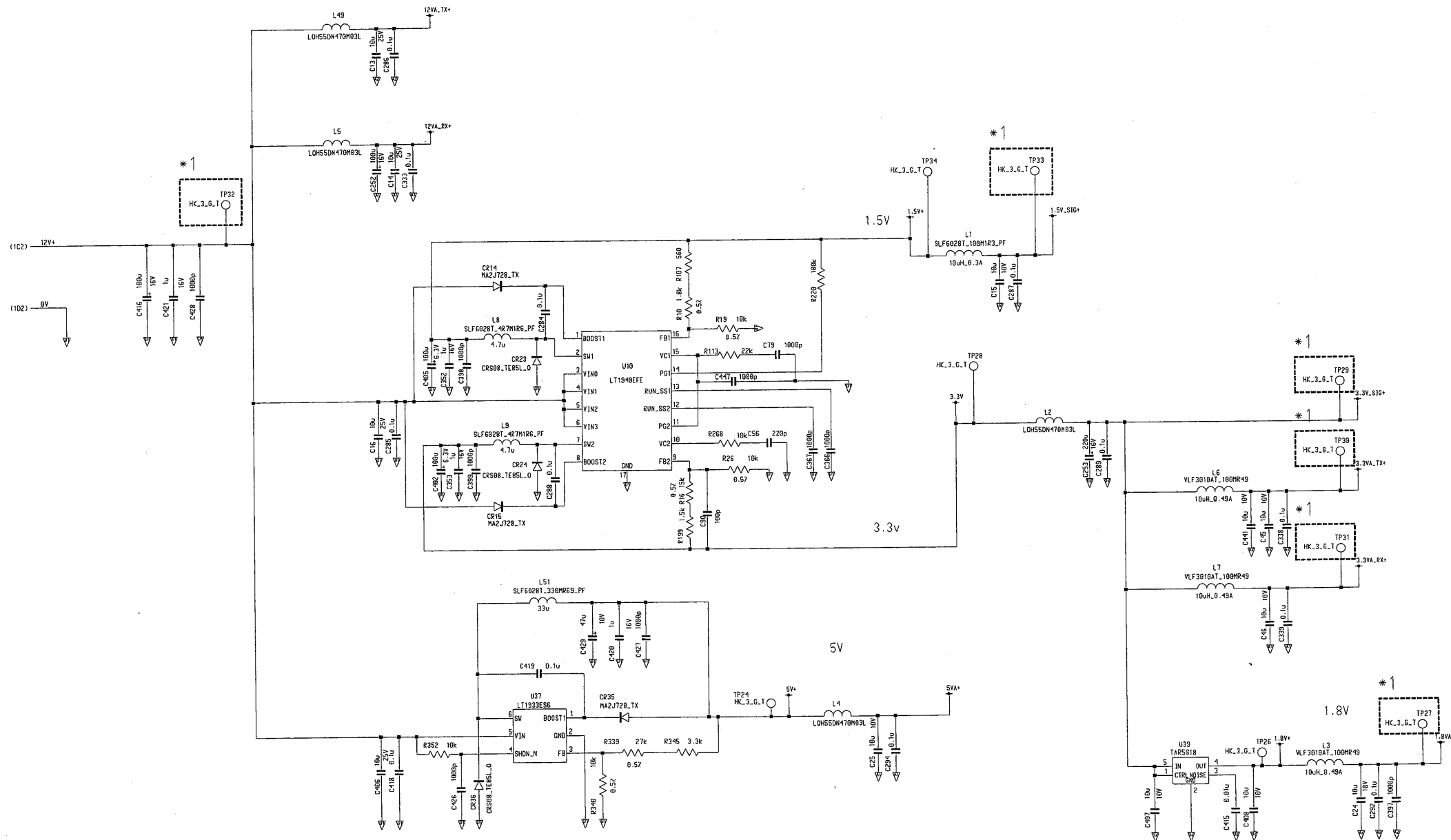

Note
*1: pattern only

DRAWN 09/06/05 T. YAMASAKI	TYPE 05P0814 (9/9)
CHECKED <i>Jun 9 '09 T. Takewo</i>	名称 MAIN&TX基板
APPROVED <i>Jun 9 '09 R. Emi</i>	回路図
SCALE MASS	NAME MAIN&TX PCB
Dwg No. C4442-K10- A	REF. No. 05-097-2109-0
	SCHMATIC DIAGRAM

9.6V-31.2VDC

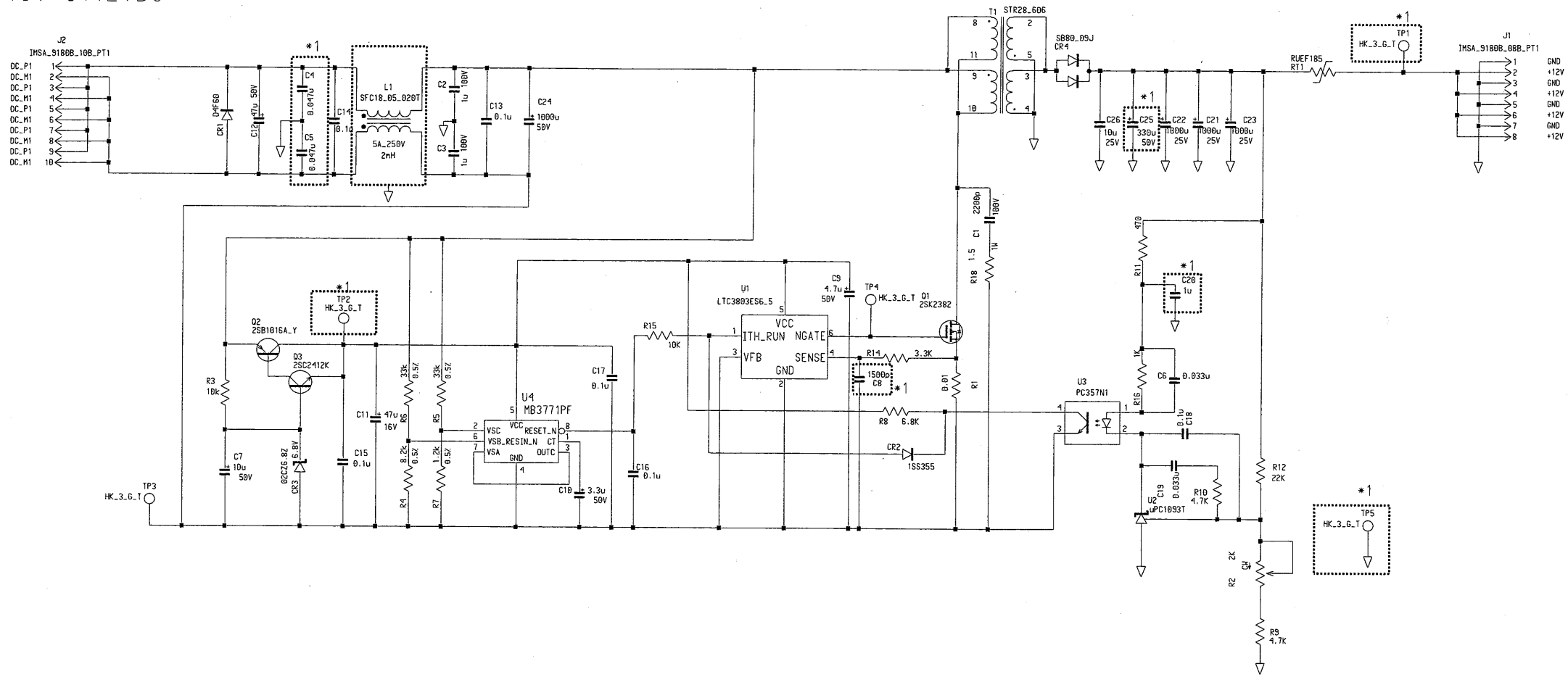

DRAWN 09/06/05 T. YAMASAKI	TYPE 05P0809
CHECKED Jun 8 '09 T. Takano	名称 PWR基板
APPROVED Jun 9 '09 R. Emi	回路図
SCALE MASS	NAME PWR PCB
Dwg No. C4442-K11- A	SCHEMATIC DIAGRAM
FA-50 1B 5	
MODEL BLOCK No.	
REF. No. 05-097-2201-0	

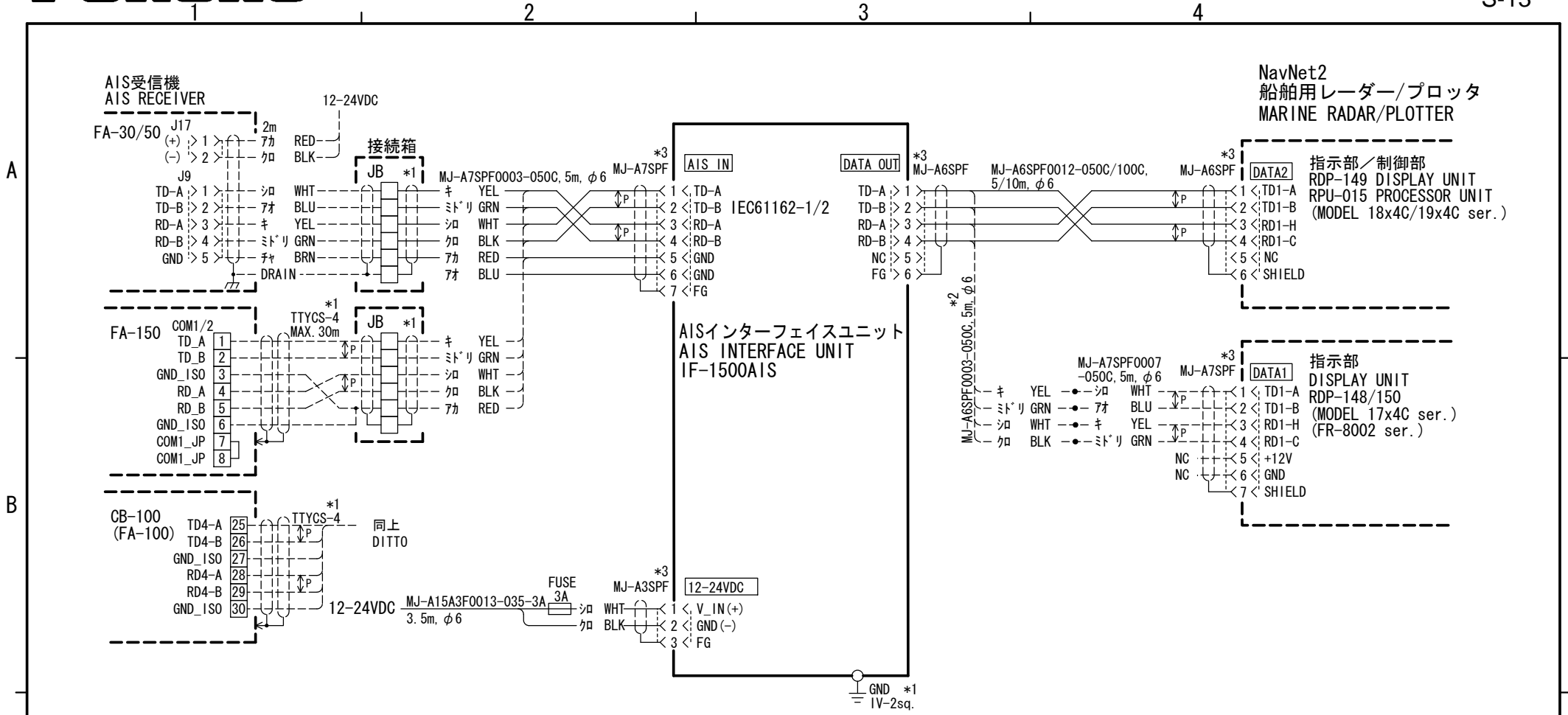

C

DRAWN	27/Mar/09 T. YAMSAKI	TYPE	IF-1500AIS
CHECKED	27/Mar/09 T. TAKENO	名称	AISインターフェイス
APPROVED	3/Apr/09 R. Esumi		相互結線図
SCALE	MASS kg	NAME	AIS INTERFACE UNIT
DWG. No.	C4435-C01-F		INTERCONNECTION DIAGRAM

FAB-151B
(150M-WZVN)
OR FA-100

M-P

TNC

GSC-001
OR FA-100

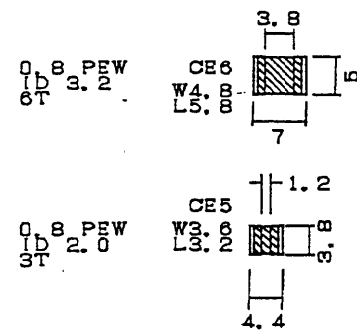
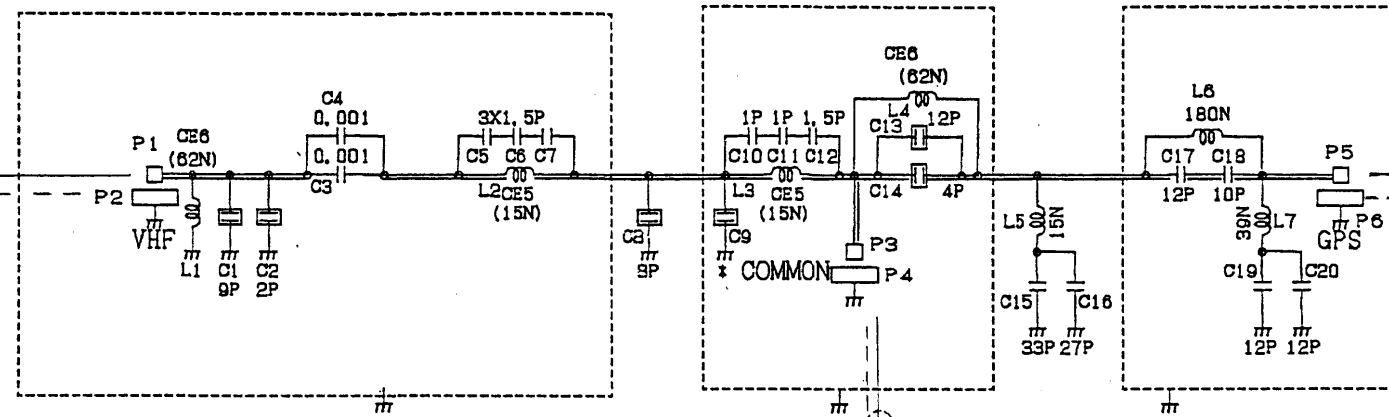

チップマイカ
W=2.7 L=3.5

その他のLCは1608

主要伝送路
W=2.8mm

VHF-GPS
分配共用器 回路図

FN 共用回路, C5 2001-11-29

N-R
N-P RG-104Y
OR PD-FB-CV

DRAWN 02/06/20 T. YAMASAKI	TYPE DB-1
CHECKED 02/6/20 Y.K.I.	名称 分配器
APPROVED 02/6/20 Y.K.I.	回路図
SCALE MASS	MODEL FA-100
BLOCK No.	NAME DISTRIBUTOR
Dwg No. C4417-K15- A	SCHEMATIC DIAGRAM

A

B

C

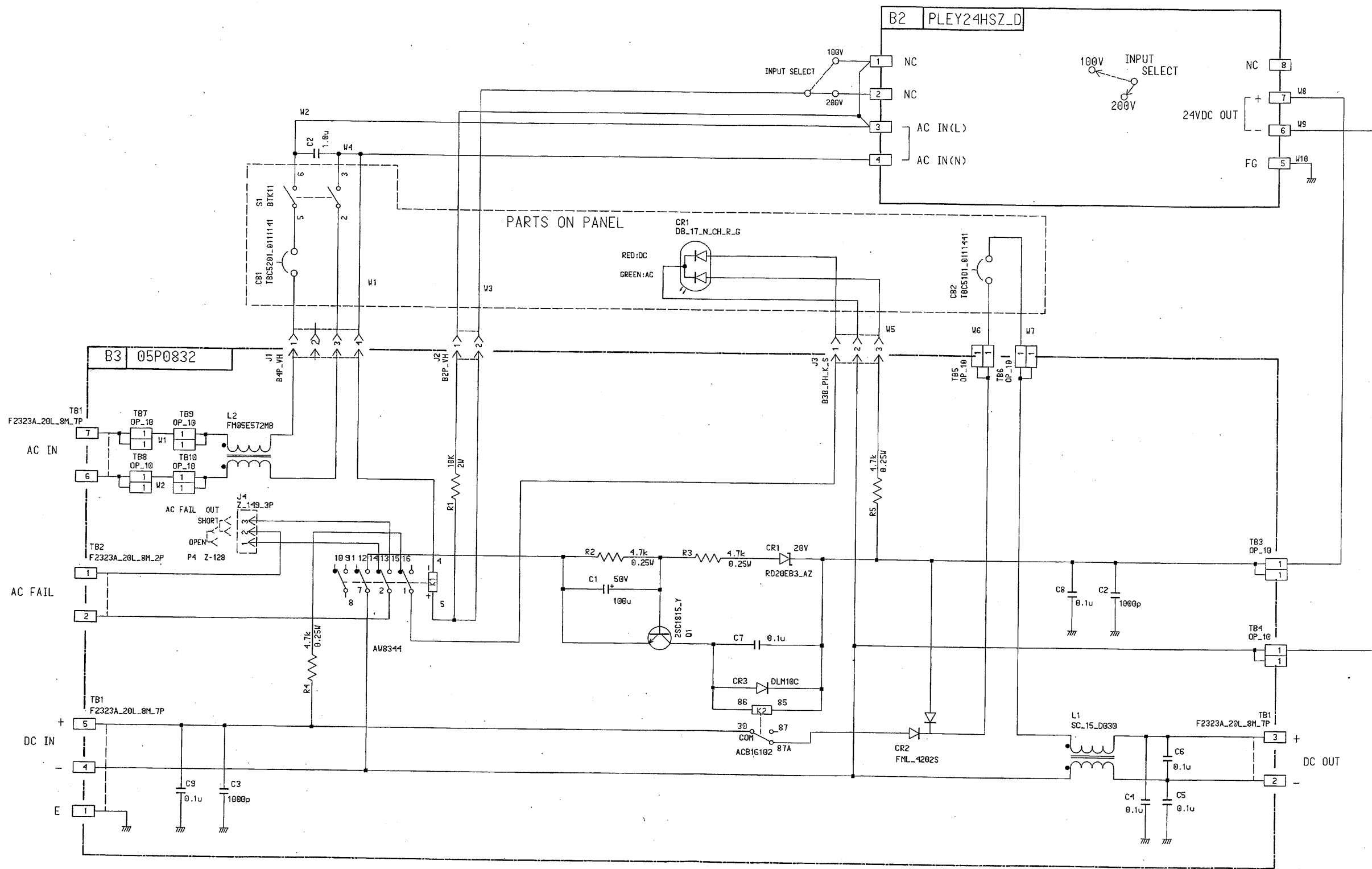

DRAWN 09/03/31 T. YAMASAKI	TYPE PR-240
CHECKED <i>Apr 8 '09 T. Yamasaki</i>	名称 AC/DC電源ユニット
APPROVED <i>Apr 14 '09 R. Emi</i>	回路図
SCALE MASS	MODEL BLOCK No.
Dwg No. C5003-K04-C	REF. No. 05-001-4387-4
NAME AC/DC POWER SUPPLY UNIT	
SCHEMATIC DIAGRAM	