

Telephone: +44(0)1460 76477
 Fax: +44(0)1460 77229
 Email: Sales@Euroquartz.co.uk

LTW33-455 SERIES
6 ELEMENT
 CERAMIC FILTER

General Specification

- High selectivity type ceramic filters
- A variety of bandwidths available
- Easily mounted to PCB
- Miniature size

Frequency v. Attenuation Characteristics

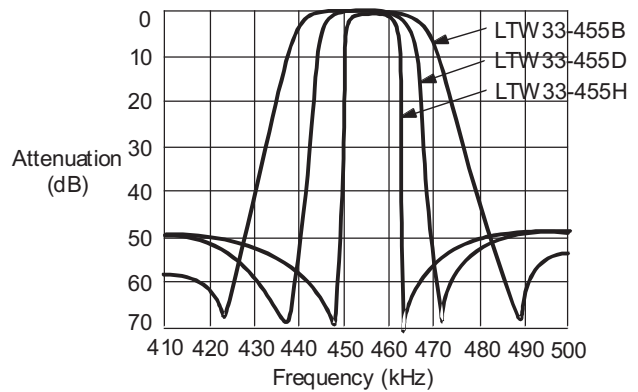
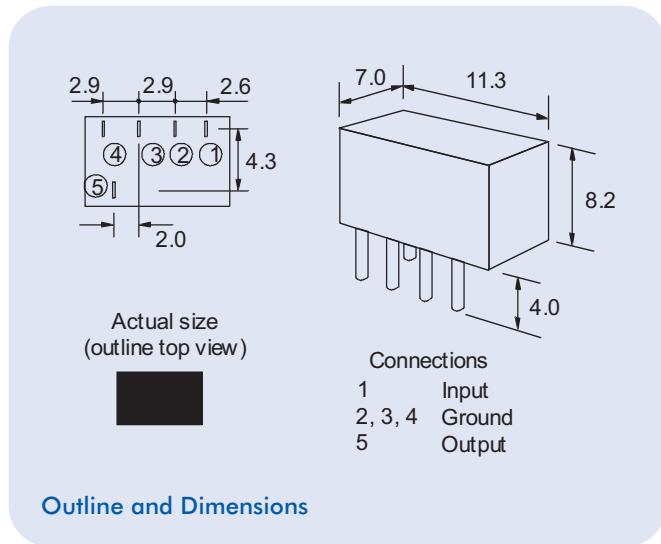

Electrical characteristics

Part Number	Centre Frequency (kHz)	Insertion Loss (dB max.)	Pass Band Ripple (dB max.)	6dB Bandwidth (kHz min.)	50dB Bandwidth (kHz min.)	Stop Band Att. ± 100 kHz (dB min.)	Input/Output Impedance (Ω)
LTW33-455B	455 \pm 2	4	2	± 15	± 30	45	1500
LTW33-455C	455 \pm 2	4	2	± 12.5	± 24	45	1500
LTW33-455D	455 \pm 1.5	6	2	± 7.5	± 15	45	1500
LTW33-455E	455 \pm 1.5	4	2	± 10	± 20	45	1500
LTW33-455F	455 \pm 1.5	6	2	± 6	± 12.5	45	2000
LTW33-455G	455 \pm 1.5	6	2	± 4.5	± 10	45	2000
LTW33-455H	455 \pm 1.0	6	2	± 3	± 9	45	2000
LTW33-455I	455 \pm 1.0	6	2	± 2	± 7.5	45	2000
LTW33-455HT	455 \pm 1.0	6	2	± 3	± 9	60	2000
LTW33-455IT	455 \pm 1.0	6	2	± 2	± 7.5	60	2000

Test Circuit

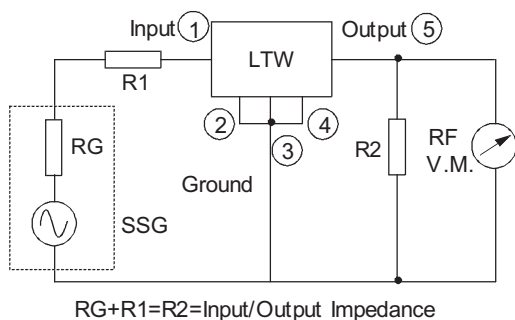

To order

Quote type number and quantity from the table above.