

# **OPERATION & MAINTENANCE MANUAL**

## **MITSUBISHI DIESEL ENGINES L-SERIES**

The operator and supervisor are requested to read this Operation and Maintenance Manual carefully before operating the engine or conducting inspection and maintenance.  
Never operate the engine or conduct maintenance work without completely understanding this manual.



July 2009

Pub. No. 99610-15140

# INTRODUCTION

This operation and maintenance manual contains detailed operation, inspection and maintenance information for engines from Mitsubishi Heavy Industries, Ltd.

Please read this manual thoroughly before proceeding with operation, inspection, and maintenance work for correct use and servicing.

Failure to follow directions in this manual may result in serious accidents.

## Limited warranty

Mitsubishi Heavy Industries, Ltd. will repair or replace parts returned to us when we judges that the parts are defective in material and/or workmanship after conducting inspection.

Mitsubishi Heavy Industries, Ltd.'s warranty is limited to the compensation work of repair or replacement of parts. The warranty coverage is effective for the original purchaser only. Those to whom ownership is later transferred are not provided with the warranty.

- 
- ♦Mitsubishi Heavy Industries, Ltd.'s makes no warranties, either expressed or implied, except as provided in this manual, including, but not limited to, warranties as to marketability, merchantability, fitness for a particular purpose or use, or against infringement of any patent.
  - ♦Mitsubishi Heavy Industries, Ltd. will not be liable for any damages or consequential damages, including, but not limited to, damages or other costs resulting from any abuse, misuse, misapplication of the engine and devices supplied from us.
  - ♦Mitsubishi Heavy Industries, Ltd. will not be liable for any damages or personal injuries resulting from any modification, without our written permission, of the engine and devices supplied from us.
  - ♦Mitsubishi Heavy Industries, Ltd. will not be liable for any damages or production losses caused by the use of fuel, engine oil and/or long life coolant (LLC) that we are not recommended.
  - ♦The owner of the engine is responsible for the performance of the required maintenance listed in this operation manual.
- Mitsubishi Heavy Industries, Ltd. may deny the warranty coverage if the engine or part has failed due to inadequate or improper maintenance.
-

## Emission warranty

### IMPORTANT

The following warranty applies to the engines that are approved of the emission regulation of the U.S. Environmental Protection Agency.

#### Warranty coverage

Mitsubishi Heavy Industries, Ltd. warrants to the first owner and each subsequent purchaser of a new non-road diesel engine that the emission control system of your engine:

- is designed, built and equipped so as to conform at the time of sales with all applicable regulation of the U.S. Environmental Protection Agency. If the vehicle in which the engine is installed is registered in the state of California, a separate California emission regulation also applies.
- is free from the defects in material and workmanship which will cause the engine to fail to meet these regulations within the warranty period.

#### Then its warranty period is

The emission warranty period is shown below.

However, if your engine warranty period is longer than the emission warranty period, the emission warranty period extends to same as the engine warranty period.

Below warranty period shall begin on the date the engine is delivered to the first owner.

If your engine is certified as	And its maximum power is	And its rated speed is	Then its warranty period is
Variable speed or constant speed	kW < 19	Any speed	1,500 hours or 2 years, whichever comes first.
Constant speed	19 ≤ kW < 37	3800 min <sup>-1</sup> or more	1,500 hours or 2 years, whichever comes first.
Constant speed	19 ≤ kW < 37	Less than 3000 min <sup>-1</sup>	3000 hours or 5 years, whichever comes first.
Variable speed	19 ≤ kW < 37	Any speed	3000 hours or 5 years, whichever comes first.
Variable speed or constant speed	kW ≥ 37	Any speed	3000 hours or 5 years, whichever comes first.

#### Warranted parts

Mitsubishi Heavy Industries, Ltd. warrants the parts which will increase the emission of pollutants when they become defective.

The followings are examples.

- Inlet/Exhaust manifold
- Crankcase ventilation system
- Fuel system
- Fuel injection nozzle

#### LIMITED WARRANTY

Refer to "LIMITED WARRANTY".

## California emission control warranty statement your warranty rights and obligations

---

### IMPORTANT

---

The following warranty applies to the engines that are approved of the emission regulation of the California Air Resources Board (CARB).

---

The **California Air Resources Board (CARB)** is pleased to explain the **emission control system warranty** on your 2008 or later engine. In California, new heavy-duty off-road engines must be designed, built, and equipped to meet the State's stringent anti-smog standards. Mitsubishi Heavy Industries, Ltd. must warrant the emission control system on your engine for the periods of time listed below provided there has been no abuse, neglect or improper maintenance of your engine.

Your emission control system may include parts such as the fuel-injection system and the air induction system. Also included may be hoses, belts, connectors and other emission-related assemblies.

Where a warrantable condition exists, Mitsubishi Heavy Industries, Ltd. will repair your heavy-duty off-road engine at no cost to you including diagnosis, parts, and labor.

#### **MANUFACTURER'S WARRANTY COVERAGE:**

The **2008** and later heavy-duty off-road engines are warranted for the Warranty Period. If any emission-related part on your engine is defective, the part will be repaired or replaced by Mitsubishi Heavy Industries, Ltd.

#### **OWNER'S WARRANTY RESPONSIBILITIES:**

- ♦As the heavy-duty off-road engine owner, you are responsible for the performance of the **required maintenance listed in your owner's manual**. Mitsubishi Heavy Industries, Ltd. recommends that you retain all receipts covering maintenance on your heavy-duty off-road engine, but Mitsubishi Heavy Industries, Ltd. cannot deny warranty solely for the lack of receipts or for your failure to ensure the performance of all scheduled maintenance.
- ♦As the heavy-duty off-road engine owner, you should however be aware that Mitsubishi Heavy Industries, Ltd. may deny you warranty coverage if your heavy-duty off-road engine or a part has failed due to abuse, neglect, improper maintenance or unapproved modifications.
- ♦Your engine is designed to operate on diesel fuel only. Use of any other fuel may result in your engine no longer operating in compliance with California's emissions requirements.
- ♦You are responsible for initiating the warranty process. The Air Resources Board suggests that you present your heavy-duty off-road engine to a Mitsubishi Heavy Industries, Ltd. dealer or distributor dealer as soon as problem exists. The warranty repairs should be completed by the dealer or distributor as expeditiously as possible.

If you have any questions regarding your warranty rights and responsibilities, you should contact Mitsubishi Engine North America at **1-630-268-0750**.

**Warranty coverage**

- (a) The warranty period shall begin on the date the engine or equipment is delivered to an ultimate purchaser.
- (b) Mitsubishi Heavy Industries, Ltd. warrants to the ultimate purchaser and each subsequent purchaser of the engine registered in the state of California that the engine is:
- (1) Designed, built and equipped so as to conform with all applicable regulations adopted by the Air Resources Board.
  - (2) Free from defects in materials and workmanship which cause the failure of a warranted part to be identical in all material respects to the parts as described in Mitsubishi Heavy Industries, Ltd.'s application for certification for a period of 5 years or 3,000 hours of operation, whichever occurs first. In the absence of a device to measure hours of use, the engine shall be warranted for a period of 5 years. For all engines rated less than 19kW, and for constant-speed engines rated under 37 kW with rated speeds higher than or equal to 3,000 min<sup>-1</sup>, the period of 2 years or 1,500 hours of operation, whichever occurs first, shall apply. In the absence of a device to measure hours of use, the engine shall be warranted for a period of 2 years.
- (c) The warranty on emission-related parts shall be interpreted as follows:
- (1) Any warranted part which is not scheduled for replacement as required maintenance in the written instructions required by Subsection (e) shall be warranted for the warranty period defined in Subsection (b) (2). If any such part fails during the period of warranty coverage, it shall be repaired or replaced by Mitsubishi Heavy Industries, Ltd. according to Subsection (4) below. Any such part repaired or replaced under the warranty shall be warranted for the remaining warranty period.
  - (2) Any warranted part which is scheduled only for regular inspection in the written instructions required by Subsection (e) shall be warranted for the warranty period defined in Subsection (b) (2). A statement in such written instructions to the effect of "repair or replace as necessary" shall not reduce the period of warranty coverage. Any such part repaired or replaced under the warranty shall be warranted for the remaining warranty period.
  - (3) Any warranted part which is scheduled for replacement as required maintenance in the written instructions required in Subsection (e) shall be warranted for the period of time prior to the first scheduled replacement point for that part. If the part fails prior to the first scheduled replacement, the part shall be repaired or replaced by Mitsubishi Heavy Industries, Ltd. according to Subsection (4) below. Any such part repaired or replaced under warranty shall be warranted for the remainder of the period prior to the first scheduled replacement point for the part.
  - (4) Repair or replacement of any warranted part under the warranty provisions shall be performed at no charge to the owner at a warranty station.
  - (5) Notwithstanding the provisions of Subsection (4) above, warranty services or repairs shall be provided at all Mitsubishi Heavy Industries, Ltd. distribution centers that are franchised to service the subject engines.
  - (6) The owner shall not be charged for diagnostic labor that leads to the determination that a warranted part is in fact defective, provided that such diagnostic work is performed at a warranty station.
  - (7) Mitsubishi Heavy Industries, Ltd. shall be liable for damages to other engine components proximately caused by failure under warranty of any warranted part.
  - (8) Throughout the engine's warranty period defined in Subsection (b) (2), Mitsubishi Heavy Industries, Ltd. shall maintain a supply of warranted parts sufficient to meet the expected demand for such parts.
  - (9) Any replacement part may be used in the performance of any maintenance or repairs and must be provided without charge to the owner. Such use shall not reduce the warranty obligations of Mitsubishi Heavy Industries, Ltd..

- (10) Add-on or modified parts that are not exempted by the Air Resources Board may not be used. The use of any non-exempted add-on or modified parts shall be grounds for disallowing a warranty claim. Mitsubishi Heavy Industries, Ltd. shall not be liable to warrant failures of warranted parts caused by the use of a non-exempted add-on or modified part.
- (11) The Air Resources Board may request and, in such case, Mitsubishi Heavy Industries, Ltd. shall provide, any documents which describe that Mitsubishi Heavy Industries, Ltd.'s warranty procedures or policies.
- (d) Warranted parts list.
- (1) Fuel metering system
    - (A) Fuel injection system.
    - (B) Air/fuel ratio feedback and control system.
    - (C) Cold start enrichment system.
  - (2) Air induction system
    - (A) Controlled hot air intake system.
    - (B) Intake manifold.
    - (C) Heat riser valve and assembly.
    - (D) Turbocharger/supercharger systems.
    - (E) Charged air cooling systems.
  - (3) Exhaust gas recirculation (EGR) system
    - (A) EGR valve body, and carburetor spacer if applicable.
    - (B) EGR rate feedback and control system.
  - (4) Air injection system
    - (A) Air pump or pulse valve.
    - (B) Valves affecting distribution of flow.
    - (C) Distribution manifold.
  - (5) Catalyst or thermal reactor system
    - (A) Catalytic converter.
    - (B) Thermal reactor.
    - (C) Exhaust manifold.
  - (6) Particulate controls
    - (A) Traps, filters, precipitators, and any other devices used to capture particulate emissions.
    - (B) Regenerators, oxidizers, fuel additive devices, and any other device used to regenerate or aid in the regeneration of the particulate control device.
    - (C) Control device enclosures and manifolding.
    - (D) Smoke puff limiters.
  - (7) Advances oxides of nitrogen (NOx) controls
    - (A) NOx absorbers.
    - (B) Lean NOx catalysts.
    - (C) Selective catalyst reduction.
    - (D) Reductant (urea/fuel) containers/dispensing systems.
  - (8) Positive crankcase ventilation (PCV) system
    - (A) PCV valve.
    - (B) Oil filler cap.

- (9) Miscellaneous items used in above systems
  - (A) Vacuum, temperature, and time sensitive valves and switches.
  - (B) Electronic control units, sensors, solenoids, and wiring harnesses.
  - (C) Hoses, belts, connectors, assemblies, clamps, fittings, tubing, sealing gaskets or devices, and mounting hardware.
  - (D) Pulleys, belts and idlers.
  - (E) Emission control information labels.
  - (F) Any other part with the primary purpose of reducing emissions or that can increase emission during failure without significantly degrading engine performance.
- (e) Mitsubishi Heavy Industries, Ltd. shall furnish with each new engine written instructions for the maintenance and use of the engine by the owner.

**LIMITED WARRANTY:**

Refer to "LIMITED WARRANTY".

## Important information

- ♦To avoid the potential hazard, accident prevention activities must be planned methodically and conducted continually by considering all aspect of engine operation, maintenance and inspection. All related personnel, including managers and supervisors, should actively participate, recognize their roles and organize themselves and their work to ensure a safe environment.
- ♦The foremost safety objective is to prevent accidents which may result in injury or death, or equipment damage.
- ♦Always observe laws or regulations of the local or federal/national government.
- ♦Mitsubishi Heavy Industries, Ltd. cannot foresee all potential dangers of the engine, potential danger resulting from human error and other causes, or danger caused by a specific environment in which the engine is used. Since there are many actions that cannot be performed or must not be performed, it is impossible to indicate every caution in this manual or on warning labels. As such, it is extremely important to follow directions in this manual and also to take general safety measures when operating, maintaining and inspecting the engine.
- ♦When the engine is used by individuals whose native language is not English, the customer is requested to provide thorough safety guidance to the operators. Also add safety, caution and operating signs that describe the original warning label statements in the native language of the operators.
- ♦The engine must be operated, maintained and inspected only by qualified persons who have thorough knowledge of engines and their dangers and who also have received risk avoidance training.
- ♦To prevent an accident, do not attempt to carry out any operation other than those described in this manual, and do not use the engine for any unapproved purpose.
- ♦When the ownership of the engine is transferred, be sure to provide this manual with the engine to the new owner. Also inform Mitsubishi Heavy Industries, Ltd. of the name and address of the new owner of the engine.
- ♦This manual is copyrighted and all rights are reserved. No part of this manual, including illustrations and technical references, may be photocopied, translated, or reproduced in any electronic medium or machine readable form without prior written consent from Mitsubishi Heavy Industries, Ltd.
- ♦The contents in this manual are subject to change at any time without notice for improvement of the engine.
- ♦Pictures or illustrations of the product in this manual may differ from those of product you have. Please note that, depending on specifications, items described in this manual may differ from those on your engine in shape, or may not be installed on your engine.
- ♦Please contact a dealer of Mitsubishi Heavy Industries, Ltd. if you need more information or if you have any questions.
- ♦If you lost or damaged this manual, obtain a new copy at a dealer of Mitsubishi Heavy Industries, Ltd. as soon as possible.
- ♦Mitsubishi Heavy Industries, Ltd. recommends the engine owner to install an hour meter on the engine due to monitor correct running intervals and to perform the maintenance at the appropriate timing.

---

## Warning indication

The following means are used to call the attention of the operators and maintenance personnel to potential dangers of the engine.

- Warning statements in the manual
- Warning labels affixed on the engine

### Warning statements

The warning statements in this manual describe potential danger in operating, inspecting or maintaining the engine, using the following 5 classifications to indicate the degree of potential hazard.

Failure to follow these directions could lead to serious accidents which could result in personal injury, or death in the worst case.

Understand the directions well, and handle engines with following directions.



Indicates an immediately hazardous situation which, if not avoided, will result in death or serious injury.



Indicates a potentially hazardous situation which, if not avoided, could result in death or serious injury.



Indicates a potentially hazardous situation which, if not avoided, may result in minor or moderate injury.



Indicates a potentially hazardous situation which, if not avoided, may result in property damage.

Note : Indicates important information or information which is useful for engine operation.

## Units of measurement

Measurements are based on the International System of Units (SI), and they are converted to the metric system units in this manual using the following conversion rates.

- ♦ Pressure :1 MPa = 10.197 kgf/cm<sup>2</sup>
- ♦ Torque :1 N·m = 0.10197 kgf·m
- ♦ Force :1 N = 0.10197 kgf
- ♦ Horsepower :1 kW = 1.341 HP = 1.3596 PS
- ♦ Meter of mercury :1 kPa = 0.75 cmHg
- ♦ Meter of water :1 kPa = 10.197 cmH<sub>2</sub>O(cmAq)
- ♦ Engine speed :1 min<sup>-1</sup> = 1 rpm
- ♦ Kinetic viscosity:1 mm<sup>2</sup>/s = 1 cSt

## Abbreviations, standards and others

- ♦ API = American Petroleum Institute
- ♦ ASTM = American Society for Testing and Materials
- ♦ ISO = International Organization for Standardization
- ♦ JIS = Japanese Industrial Standards
- ♦ LLC = Long Life Coolant
- ♦ MIL = Military Specifications and Standards
- ♦ MSDS = Material Safety Data Sheet
- ♦ SAE = Society of Automotive Engineers

# CONTENTS

## Chapter 1

### BASIC SAFETY PRECAUTIONS

Fire and explosions .....	1-1
Keep flames away .....	1-1
Keep engine surrounding area tidy and clean..	1-1
Care for fuel, oil and exhaust gas leakage.....	1-1
Use explosion-proof lighting apparatus.....	1-1
Prevent electrical wires from short-circuiting....	1-1
Keep fire extinguishers and a first-aid kit handy .....	1-1
Stay clear of all rotating and moving parts .....	1-2
Install protective covers around rotating parts .	1-2
Check work area for safety .....	1-2
Stay clear of moving parts while engine is running .....	1-2
Lockout and tagout .....	1-2
Keep engine stopped during servicing .....	1-2
Always restore engine turning tools after use ..	1-2
Changing the engine speed setting is prohibited .....	1-2
Be careful of exhaust fume poisoning .....	1-3
Operate engine in a well-ventilated area.....	1-3
Be careful of falling down .....	1-3
Lift engine carefully .....	1-3
Do not climb onto the engine .....	1-3
Always prepare stable scaffold .....	1-3
Protect ears from noise .....	1-4
Wear ear plugs.....	1-4
Be careful of burns .....	1-4
Do not touch the engine during or immediately after operation.....	1-4
Do not open the radiator filler cap when the engine is hot.....	1-4
Do not touch high pressure injection fuel.....	1-4
Refill coolant only after the coolant temperature dropped .....	1-4
Be careful when handling fuel, engine oil or LLC .....	1-5
Use only specified fuel, engine oil and LLC .....	1-5
Handle LLC carefully.....	1-5
Proper disposal of waste oil, LLC and coolant .....	1-5
When abnormality occurs .....	1-5
Do not add coolant immediately after a sudden stop due to overheating.....	1-5

Avoid immediate restart after abnormal stop....	1-5
Avoid continuous engine operation at low oil pressure .....	1-5
If belt breaks, stop engine immediately .....	1-5
Service battery .....	1-6
Handle the battery correctly .....	1-6
Other cautions.....	1-7
Never modify engine .....	1-7
Observe safety rules at work site .....	1-7
Work clothing and protective gear.....	1-7
Never break seals .....	1-7
Perform all specified pre-operation inspections and periodic inspections.....	1-7
Break-in the engine .....	1-7
Warm up the engine before use.....	1-7
Never operate the engine in an overloaded condition .....	1-7
Conduct cooling operation before stopping the engine .....	1-8
Protection of the engine against water entry ...	1-8
Conduct proper maintenance of air cleaner .....	1-8
Use of tools optimum for each work.....	1-8
Avoidance of prolonged time of starter operation .....	1-8
Do not turn off the battery switch during operation .....	1-8
Cautionary instructions for transporting the engine .....	1-8

## Chapter 2

### NAME OF PARTS

Engine external diagrams .....	2-1
Equipment and instrument.....	2-3
Starter switch .....	2-3
Preheat indicator .....	2-3
Water temperature meter and thermo unit .....	2-4
Ammeter.....	2-4
Hour meter .....	2-4
Stop solenoid .....	2-5
Engine protection devices.....	2-6
Oil pressure switch.....	2-6
Thermo switch .....	2-6
Air cleaner indicator .....	2-6

**Chapter 3  
OPERATION**

Preparations for operation .....3-1  
 Engine external - Inspect ..... 3-1  
 Battery electrolyte level - Inspect ..... 3-1  
 Fuel tank oil level - Check ..... 3-2  
 Engine oil level - Check ..... 3-2  
 Coolant level - Check ..... 3-3  
**Starting .....3-4**  
 Automatic glow plug ..... 3-4  
 Manual glow plug ..... 3-4  
**Warm up operation .....3-5**  
 Checking engine oil pressure ..... 3-5  
 External inspection during warm up ..... 3-5  
**Operation .....3-6**  
 Cautions when operating ..... 3-6  
 Inspection during operation ..... 3-6  
**Stopping .....3-7**  
 Inspection after stopping ..... 3-7

**Chapter 4  
FUEL**

Recommended fuel .....4-1  
 Handling fuel.....4-1

**Chapter 5  
ENGINE OIL**

Recommended engine oil.....5-1  
 Selection of oil viscosity.....5-1  
 Handling engine oil .....5-1  
 Engine oil performance requirements..5-2  
 Engine oil deterioration mechanisms...5-2  
 Definition of properties of engine oil ....5-3  
 Viscosity ..... 5-3  
 Total base number ..... 5-3  
 Total acid number ..... 5-3  
 Water content..... 5-3  
 Flash point..... 5-3  
 Insoluble..... 5-3  
 Service Limits of engine oil.....5-4

**Chapter 6  
COOLANT**

Recommended water for coolant ..... 6-1  
 Long life coolant (LLC) ..... 6-1  
 Genuine LLC ..... 6-1  
 Other brand LLCs ..... 6-2  
 Standard for other brand LLC ..... 6-2  
 General demands of LLC ..... 6-2  
 LLC specification ..... 6-3  
 Maintenance of LLC ..... 6-5  
 Replacement intervals of LLC ..... 6-5  
 LLC concentration ..... 6-5  
 Importance of LLC ..... 6-6  
 Characteristics of LLC additive and  
 important notes ..... 6-6  
 Examples of abnormalities caused by  
 LLC (amine type) ..... 6-6  
 Pitting of iron parts ..... 6-6  
 Corrosion of aluminum parts ..... 6-6  
 Pitting and clogging of the radiator ..... 6-6

**Chapter 7  
MAINTENANCE SCHEDULE**

How to use the maintenance  
 schedule..... 7-1  
 Maintenance schedule ..... 7-2

## **Chapter 8**

### **PERIODIC INSPECTION AND MAINTENANCE PROCEDURES**

Basic engine .....	8-1
Belt and belt tension - Inspect and Adjust.....	8-1
Fuel system .....	8-2
Fuel tank - Drain water.....	8-2
Solenoid fuel pump filter - Inspect and clean ...	8-2
Fuel system - Bleed air .....	8-3
Water sedimenter - Drain water .....	8-5
Fuel filter (cartridge type) - Replace.....	8-5
Fuel filter element (switching cock type)	
- Replace.....	8-6
Solenoid fuel pump filter - Replace .....	8-6
Lubricating system.....	8-7
Engine oil and Oil filter - Replace.....	8-7
Cooling system .....	8-10
Coolant - Change .....	8-10
Radiator fins - Check and Clean .....	8-13
Inlet and exhaust systems.....	8-14
Air cleaner - Check.....	8-14
Air cleaner element - Clean, Check and	
Replace .....	8-15
Electrical system.....	8-16
Starter - Inspect.....	8-17
Alternator - Inspect.....	8-17

## **Chapter 9**

### **LONG-TERM STORAGE**

Long-term storage .....	9-1
Storing the engine in a non-operable	
condition for 3 months or more.....	9-1
Preparation for storage .....	9-1
Maintenance during storage.....	9-1
Using the engine after storage.....	9-2
Storing the engine in an operable	
condition for 3 months or more.....	9-2
Operating the engine for maintenance.....	9-2

## **Chapter 10**

### **TRANSPORTATION**

Lifting the engine.....	10-1
-------------------------	------

## **Chapter 11**

### **TROUBLESHOOTING**

General precautions.....	11-1
Contact a dealer of Mitsubishi Heavy	
Industries, Ltd. for repair service .....	11-1
Considerations before work .....	11-1
Cautions against contamination .....	11-1
Cautions regarding parts handling .....	11-1
Work safety .....	11-1
Troubleshooting .....	11-2
The starter does not crank or cranks slowly,	
resulting in start failure .....	11-2
The starter cranks, but the engine does not	
start .....	11-2
Output decrease.....	11-3
Exhaust smoke is white or blue.....	11-4
Exhaust smoke is black or charcoal.....	11-5
Fuel consumption is high .....	11-6
Engine oil consumption is high.....	11-7
Overheating.....	11-8
Low engine oil pressure .....	11-8
When fuel has run out.....	11-9

## **Chapter 12**

### **MAIN SPECIFICATIONS**

Main specifications.....	12-1
--------------------------	------

**List of illustrations**

Fig. 2-1	Engine left view .....	2-1	Fig. 8-13	Oil filter - Change .....	8-9
Fig. 2-2	Engine right view .....	2-1	Fig. 8-14	Oil filter .....	8-9
Fig. 2-3	Engine left view .....	2-2	Fig. 8-15	Radiator filler cap .....	8-10
Fig. 2-4	Engine right view .....	2-2	Fig. 8-16	Coolant drain cock (radiator).....	8-10
Fig. 2-5	Starter switch.....	2-3	Fig. 8-17	Coolant drain plug (engine).....	8-11
Fig. 2-6	Preheat indicator .....	2-3	Fig. 8-18	Radiator coolant level.....	8-12
Fig. 2-7	Water temperature meter and thermo unit.....	2-4	Fig. 8-19	Reserve tank .....	8-12
Fig. 2-8	Ammeter.....	2-4	Fig. 8-20	Radiator fins - Clean .....	8-13
Fig. 2-9	Hour meter .....	2-4	Fig. 8-21	Air cleaner - Check.....	8-14
Fig. 2-10	Stop solenoid.....	2-5	Fig. 8-22	Air cleaner element - Remove.....	8-15
Fig. 2-11	Oil pressure switch .....	2-6	Fig. 8-23	Air cleaner element - Clean and Check .....	8-15
Fig. 2-12	Thermo switch .....	2-6	Fig. 8-24	Air cleaner - Check.....	8-15
Fig. 2-13	Air cleaner indicator.....	2-6	Fig. 8-25	Battery electrolyte level - Inspect .....	8-16
Fig. 3-1	Battery electrolyte level - Inspect .....	3-1	Fig. 8-26	Specific gravity of battery electrolyte - Check .....	8-16
Fig. 3-2	Fuel tank oil level - Check .....	3-2	Fig. 8-27	Starter - Inspect.....	8-17
Fig. 3-3	Oil filler and Oil level gauge.....	3-2	Fig. 8-28	Alternator - Inspect.....	8-17
Fig. 3-4	Radiator filler cap .....	3-3	Fig. 10-1	Hangers.....	10-1
Fig. 3-5	Radiator coolant level.....	3-3	Fig. 10-2	Engine's center of gravity (standard specification) .....	10-1
Fig. 3-6	Reserve tank coolant level .....	3-3			
Fig. 4-1	Recommended fuel .....	4-1			
Fig. 5-1	Recommended engine oil.....	5-1			
Fig. 5-2	Selection of oil viscosity .....	5-1			
Fig. 6-1	GLASSY - LLC .....	6-1			
Fig. 8-1	Belt and belt tension - Inspect and Adjust .....	8-1			
Fig. 8-2	Fuel tank - Drain water .....	8-2			
Fig. 8-3	Solenoid fuel pump filter - Inspect and clean.....	8-2			
Fig. 8-4	Fuel filter element (switching cock type) - Bleed air.....	8-3			
Fig. 8-5	Fuel filters (cartridge type) - Bleed air ..	8-3			
Fig. 8-6	Water sedimenter - Bleed air.....	8-4			
Fig. 8-7	Water sedimenter - Drain water .....	8-5			
Fig. 8-8	Fuel filter (cartridge type) - Replace .....	8-5			
Fig. 8-9	Fuel filter element (switching cock type) - Replace.....	8-6			
Fig. 8-10	Solenoid fuel pump filter - Replace .....	8-6			
Fig. 8-11	Engine oil drain plug.....	8-7			
Fig. 8-12	Engine oil - Refill .....	8-8			

**List of tables**

Table 3-1 Preheat duration  
(automatic grow plug)..... 3-4

Table 3-2 Preheat duration (manual grow plug)... 3-4

Table 3-3 Standard values at rated speed ..... 3-6

Table 4-1 Recommended limit and use limit of  
fuel property ..... 4-2

Table 5-1 Engine oil properties..... 5-4

Table 6-1 Water quality standards..... 6-1

Table 6-2 LLC specification ..... 6-3

Table 6-3 Recommended LLC concentration..... 6-5

Table 7-1 Maintenance schedule ..... 7-2

Table 8-1 Specific gravity of electrolyte ..... 8-16

Table 9-1 Recommended rust-preventive oil  
and corrosion inhibitor ..... 9-1

Table 11-1 The starter does not crank or cranks  
slowly, resulting in start failure ..... 11-2

Table 11-2 The starter cranks, but the engine  
does not start..... 11-2

Table 11-3 Output decrease..... 11-3

Table 11-4 Exhaust smoke is white or blue..... 11-4

Table 11-5 Exhaust smoke is black or charcoal ... 11-5

Table 11-6 Fuel consumption is high..... 11-6

Table 11-7 Engine oil consumption is high..... 11-7

Table 11-8 Overheating..... 11-8

Table 11-9 Low engine oil pressure ..... 11-8

Table 12-1 Main specifications ..... 12-1



# Chapter 1 BASIC SAFETY PRECAUTIONS

## Fire and explosions

 **WARNING**

### Keep flames away

Do not use flames near the engine (in the engine room). Fuel vapor or other gas can catch fire and produce dangerous situations.



Wipe off spilled fuel, oil and LLC immediately and thoroughly. Spilled fuel, oil and LLC may ignite and cause a fire.

Store fuel and engine oil in a well-ventilated area.

Make sure that the caps of fuel and engine oil containers are tightly closed.

### Keep engine surrounding area tidy and clean

Do not leave combustible or explosive materials, such as fuel, engine oil and LLC, near the engine. Such substances can cause fire or explosion.

Remove dust, dirt and other foreign materials accumulated on the engine and surrounding parts thoroughly. Such materials can cause fire or the engine to overheat. In particular, clean the top surface of the battery thoroughly. Dust can cause a short-circuit.

### Care for fuel, oil and exhaust gas leakage

If any fuel, oil or exhaust gas leakage is found, immediately take corrective measures to stop it.

Such leakages, if left uncorrected, can cause fuel or engine oil to reach hot engine surfaces or hot exhaust gas to contact flammable materials, possibly leading to personal injury and/or damage to equipment.

### Use explosion-proof lighting apparatus

When inspecting fuel, engine oil, coolant, battery electrolyte, etc., use a flameproof light. An ordinary lighting apparatus may ignite gas and cause it to explode.

### Prevent electrical wires from short-circuiting

Avoid inspecting or servicing the electrical system with the ground cable connected to the battery. Otherwise, a fire could result from short-circuiting. Be sure to disconnect the battery cable from the negative (-) terminal before beginning with the work procedure.

Short-circuits, possibly resulting in fire, may be caused by a loose terminal or damaged cable/wire. Inspect the terminals, cables and wires, and repair or replace the faulty parts before beginning with the service procedure.

### Keep fire extinguishers and a first-aid kit handy

Keep fire extinguishers handy, and become familiar with their usage. Keep a first-aid kit at the designated place where it is easily accessible by anyone at any time.



Establish response procedures to follow in the event of fire or accident. Provide an emergency evacuation route and contact points and means of communication in case of emergency.

## Stay clear of all rotating and moving parts

 **WARNING**

### Install protective covers around rotating parts

Make sure the protective covers of the engine are correctly installed. Repair any damaged or loose covers. Never remove the covers such as damper cover, camshaft cover, or rocker cover that enclose the revolving parts during operation.



When the engine is coupled to driven equipment, be sure to provide protective covers over the parts such as the connecting belts and couplings that are exposed.

Never remove protective covers.

### Check work area for safety

Before starting the engine, make sure no one is near the engine and tools are not left on or near the engine. Verbally notify persons within the immediate area when starting the engine.

When the starter device is posted with a sign that prohibits startup operation, do not operate the engine.

### Stay clear of moving parts while engine is running

Do not approach rotating or sliding parts of the engine while the engine is running. Keep objects likely to be caught by rotating parts away from such parts.



If any part of the clothing or outfitting is caught by a rotating part, serious bodily injuries could result.

### Lockout and tagout

Be sure to lockout and tagout before starting inspection and maintenance.

Lockout and tagout are effective methods of cutting off machines and equipment from energy sources.

To accomplish the lockout/tagout, remove the starter switch key, set the battery switch to "OFF" position and attach a "Do Not Run" or similar caution tag to the starter switch.

The starter switch key must be kept by the person who performs inspection and maintenance during the work.

### Keep engine stopped during servicing

Be sure to stop the engine before proceeding to inspection and service procedure. Never attempt to make adjustments on the engine parts while the engine is running.

Rotating parts such as belt can entangle your body and cause serious injuries.

### Always restore engine turning tools after use

Be sure to remove all turning tools used during maintenance and inspection work. Remember also that the turning gear must be returned to the operating condition before starting the engine.

Starting the engine with the turning tools inserted or with the turning gear in engagement can lead to not only engine damage but also personal injuries.

### Changing the engine speed setting is prohibited

Never change engine speed setting. Tampering with the setting can cause the engine and its coupled machine to operate at excessive speeds and result in accidents.

## Be careful of exhaust fume poisoning

### WARNING

### Operate engine in a well-ventilated area

If the engine is installed in an enclosed area, and the exhaust gas is ducted outside, ensure that there is no exhaust gas leakage from duct joints.



When using the engine as portable generator set, do not run it in doors such as a warehouse or tunnel, or in an poorly-ventilated area near the shielding. When running it indoors by necessity, discharge the exhaust gas to outside and thoroughly ventilate the room. Make sure the exhaust gas is not discharged directly to surrounding buildings, plants or living passersby. Exhaust gas from the engine contains carbon monoxide and other harmful substances. Operating the engine in an poorly-ventilated area can produce gas poisoning.

## Be careful of falling down

### WARNING

### Lift engine carefully

To lift the engine, use slings capable of supporting the weight of the engine.

Attach the wire rope to the hangers provided on the engine using a correct sling.

During lifting process, keep the engine in a well-balanced position by taking the center of gravity of the engine into consideration.

Keep the angle formed by slings attached to hangers within 60°. If the angle exceeds this limit, excessive load could be imposed on the hangers and this could damage the hangers and result in a serious accident. If the wire rope contacts the engine directly, place a cloth or other soft padding to avoid damage to the engine and wire rope.



### Do not climb onto the engine

Do not climb onto the engine, nor step on any engine parts located on the lateral sides.

To work on parts located on the upper section of engine, use a ladder, stool, etc., that was firmly secured.

Climbing on the engine may not only damage engine parts but also cause falling down from the engine and result in personal injuries.

### Always prepare stable scaffold

When working on the upper part of the engine and other hard-to-reach places, use a stable work platform.

Standing on a decrepit stool or parts box may result in personal injury.

Do not place any unnecessary objects on a work platform.



## Protect ears from noise

 CAUTION

### Wear ear plugs

Always wear ear plugs when entering the machine room (engine room). Combustion sound and mechanical noise generated by the engine can cause hearing problems.



## Be careful of burns

 CAUTION

### Do not touch the engine during or immediately after operation

To avoid burns, do not touch the engine during or immediately after operation.

A hot engine can cause burns.

To conduct maintenance and inspection work, wait until the engine has cooled sufficiently by checking the temperature gauge.



### Do not open the radiator filler cap when the engine is hot

Never open the radiator filler cap while the engine is running or immediately after the engine is stopped.

When opening the cap, stop the engine and allow the coolant temperature to lower sufficiently.

When opening the radiator filler cap, open slowly to discharge the pressure inside the tank. Also to avoid a risk of getting scalded by steam, wear thick rubber gloves or wrap a cloth around the cap.

When closing the cap, be sure to tighten securely.

The coolant is hot while engine is running and immediately after the engine stops. If the cap is opened when the coolant is at operating temperature, steam and hot coolant may blow out and result in burns.

### Do not touch high pressure injection fuel

If fuel leaks or sprays out from the high pressure injection pipe, do not touch the fuel.

Fuel in the fuel injection pipes is under high pressure and if the fuel contact your skin, it goes into deep tissues and may result gangrene.

### Refill coolant only after the coolant temperature dropped

When refilling of coolant, perform it after coolant temperature drops, not immediately after the engine is stopped. Otherwise you are scalded with hot coolant.

## Be careful when handling fuel, engine oil or LLC

### CAUTION

### Use only specified fuel, engine oil and LLC

Use fuel, oil and LLC specified in this manual, and handle them carefully.

Use of any other fuel, oil or LLC, or improper handling may cause various engine problems and malfunctions.

Obtain the MSDS issued by the fuel, oil and LLC suppliers, and follow the directions in the MSDSs for proper handling.

### Handle LLC carefully

When handling LLC, always wear rubber gloves and a protective face mask. If LLC or cooling water containing LLC comes into contact with your skin or eyes, or if it is swallowed, you would suffer from inflammation, irritation or poisoning.

Should LLC be accidentally swallowed, induce vomiting immediately and seek medical attention. Should LLC enter your eyes, flush them immediately with plenty of water and seek medical attention. If LLC splashes onto your skin or clothing, wash it away immediately with plenty of water.

Keep flames away from LLC. The LLC can catch flames, causing a fire. Coolant (containing LLC) drained from the engine is toxic. Never dispose of coolant into regular sewage. Abide by the applicable law and regulations when discarding drained coolant.

### Proper disposal of waste oil, LLC and coolant

Do not discharge waste engine oil, LLC and coolant into sewerage, river, lake or other similar places. Such a way of disposal is strictly prohibited by laws and regulations.

Dispose of waste oil, LLC and coolant and other environmentally hazardous waste in accordance with the applicable law and regulations.

## When abnormality occurs

### CAUTION

### Do not add coolant immediately after a sudden stop due to overheating

If the engine stops suddenly or if you have no choice but stop the engine suddenly due to overheating, do not add coolant immediately.

Adding water while the engine is hot can damage parts such as cylinder heads due to a sudden drop of temperature. Add coolant gradually after the engine has completely cooled.

### Avoid immediate restart after abnormal stop

If the engine stops abnormally, do not restart the engine immediately. If the engine stops with an alarm, check and remedy the cause of the problem before restarting. Sustained use of the engine without any remedy could result in serious engine problems.

### Avoid continuous engine operation at low oil pressure

If an abnormal engine oil pressure drop is indicated, stop the engine immediately, and inspect the lubrication system to locate the cause. Continuous engine operation with low oil pressure could cause bearings and other parts to seize.

### If belt breaks, stop engine immediately

If the belt breaks, stop the engine immediately. Continuous engine operation with the broken belt could cause the engine to overheat and thereby the coolant to boil into steam, which may gush out from the reserve tank or radiator, and you may be scalded with it.

## Service battery

 CAUTION

### Handle the battery correctly

- ♦ Never use flames or allow sparks to generate near the battery. The battery releases flammable hydrogen gas and oxygen gas. Any flames or sparks in the vicinity could cause an explosion.
- ♦ Do not use the battery when the battery electrolyte level of which is below "LOWER LEVEL" line. Sustained use of the battery could result in an explosion.
- ♦ Do not short the battery terminals with a tool or other metal object.
- ♦ When removing battery, always remove the plug from the negative (-) terminal first. When connecting battery, always connect the plug to the positive (+) terminal first.
- ♦ Remove all plugs, then charge the battery in a well-ventilated area.
- ♦ Make sure the cable clamps are securely installed on the battery terminals. A loose cable clamp can cause sparks that may result in an explosion.
- ♦ Before servicing electrical components or conducting electric welding, set the battery switch to the "Open/OFF" position or remove the plug from the negative (-) terminal to cut off the electrical current.
- ♦ Battery electrolyte contains dilute sulfuric acid. Careless handling of the battery can cause the loss of sight and/or skin burns. Also, do not consume the battery electrolyte.
- ♦ Wear protective goggles and rubber gloves when working with the battery (when adding water, charging, etc.)
- ♦ If battery electrolyte is spilled onto the skin or clothing, immediately wash it away with lots of water. Use soap to thoroughly clean.
- ♦ The battery electrolyte can cause the loss of sight if splashing into the eyes. If it gets into the eyes, immediately flush it away with plenty of clean water, and seek immediate medical attention.
- ♦ If the battery electrolyte is accidentally consumed, gargle with plenty of water, then drink lots of water, and seek immediate medical attention.



## Other cautions



### Never modify engine

Unauthorized modification of the engine will void our warranty.

Modification of the engine may not only cause engine damage but also produce personal injuries.

If there is a need to modify the engine, contact a dealer of Mitsubishi Heavy Industries, Ltd.

### Observe safety rules at work site

Observe the safety rules established at your workplace when operating and maintaining the engine.

Do not operate the engine if you are feeling ill, inform your supervisor of your condition. Operation of the engine with reduced awareness may cause improper operation that could result in accidents.

When working in a team for two or more people, use specified hand signals to communicate among workers.

### Work clothing and protective gear

Wear a hardhat, face shield, safety shoes, dust mask, gloves and other protective gear as needed. When handling compressed air, wear safety goggles, a hardhat, gloves and other necessary protective gear.

Works without wearing proper protective gear could result in serious injuries.

### Never break seals

To ensure proper engine operation, the fuel control linkage is sealed to prevent accidental change of the injection volume and rotation speed settings. Operating the engine without these seals in place can cause problems described below, and also invalidates the warranty.

- Rapid wear of sliding and rotating parts
- Engine damage such as seizing of engine parts
- Considerably increased consumption of fuel and lubricating oil
- Degradation of engine performance due to improper balance between fuel injection volume and governor operation or overrunning of the engine which could result in a serious accident

### Perform all specified pre-operation inspections and periodic inspections

Conduct the pre-operation inspections and periodic inspections as described in this manual.

Failure to conduct the specified inspections may cause various engine problems, damage to parts, and serious accidents.

### Break-in the engine

To break-in new engines or overhauled engines, operate the engine at a speed lower than the rated speed in a light load condition during the first 50 hours of operation.

Operating new engines or overhauled engines in a severe condition during the break-in period shortens the service life of the engine.

### Warm up the engine before use

After starting the engine, run the engine at low idling speeds for 5 to 10 minutes for warm up. Start the work after this operation is completed. Warm up operation circulates the lubricant through the engine. Therefore, individual engine parts are well lubricated before they are subjected to heavy loads.

Warm up operation circulates lubricants in the engine and contributes to a longer service life and economical operation.

Do not conduct warm up operation for prolonged period of time. Prolonged warm up operation causes carbon build-up in the cylinders that leads to incomplete combustion.

### Never operate the engine in an overloaded condition

If the engine shows an overloaded condition such as black exhaust smoke, reduce the load immediately to operate the engine at an appropriate output and load. Overloading causes not only high fuel consumption but also excessive carbon deposits inside the engine. Carbon deposits cause various problems and will shorten the service life of the engine.

## **Conduct cooling operation before stopping the engine**

Before stopping the engine, let it idle in low gear for 5 to 6 minutes to cool down.

Stopping the engine immediately after high-load operation will cause engine parts to heat up and shorten the service life of the engine.

During cooling operation, check the engine for abnormalities.

## **Protection of the engine against water entry**

Do not allow rainwater, etc. to enter the engine through the air inlet or exhaust openings.

Do not wash the engine while it is operating. Cleaning fluid (water) can be sucked into the engine.

Starting the engine with water inside the combustion chambers can cause the water hammer action which may result in internal engine damage and serious accidents.

## **Conduct proper maintenance of air cleaner**

The major cause of abnormal wear on engine parts is dust from intake air. Worn parts produce many problems such as an increase of oil consumption, decrease of output, and starting difficulties. For effective removal of dust from intake air, maintain the engine with air cleaner according to the following instructions.

- ♦Never service the air cleaner while the engine is running. Operating the engine without the air cleaner can suck particles of foreign matter into the engine and could result in serious accidents.
- ♦Remove the air cleaner slowly to prevent dust accumulated on the element from falling off. After removing the air cleaner, immediately cover the air inlet with plastic sheet or similar means to prevent dust from entering the engine.

## **Use of tools optimum for each work**

Always keep in mind to select most appropriate tools for the work to be performed and use them correctly. If tools are damaged, replace them with new tools.

## **Avoidance of prolonged time of starter operation**

Do not use the starter for more than 10 seconds at a time. If the engine does not start, wait for at least 1 minute before cranking again.

Continuous operation of the starter will drain the battery power and cause the starter to seize.

## **Do not turn off the battery switch during operation**

Do not turn off the battery switch during operation.

If the battery switch is turned OFF when the engine is running, not only various meters will stop working but also the alternator may have its diode and transistor deteriorated.

## **Cautionary instructions for transporting the engine**

When transporting the engine on a truck, consider the engine weight, width and height to ensure safety.

Abide by road traffic law, road vehicles act, vehicle restriction ordinance and other pertinent laws.

# Chapter 2 NAME OF PARTS

## Engine external diagrams

The external diagram is for the standard type of the engine. The installed equipment and shapes differ according to the engine type.

### L2E left view

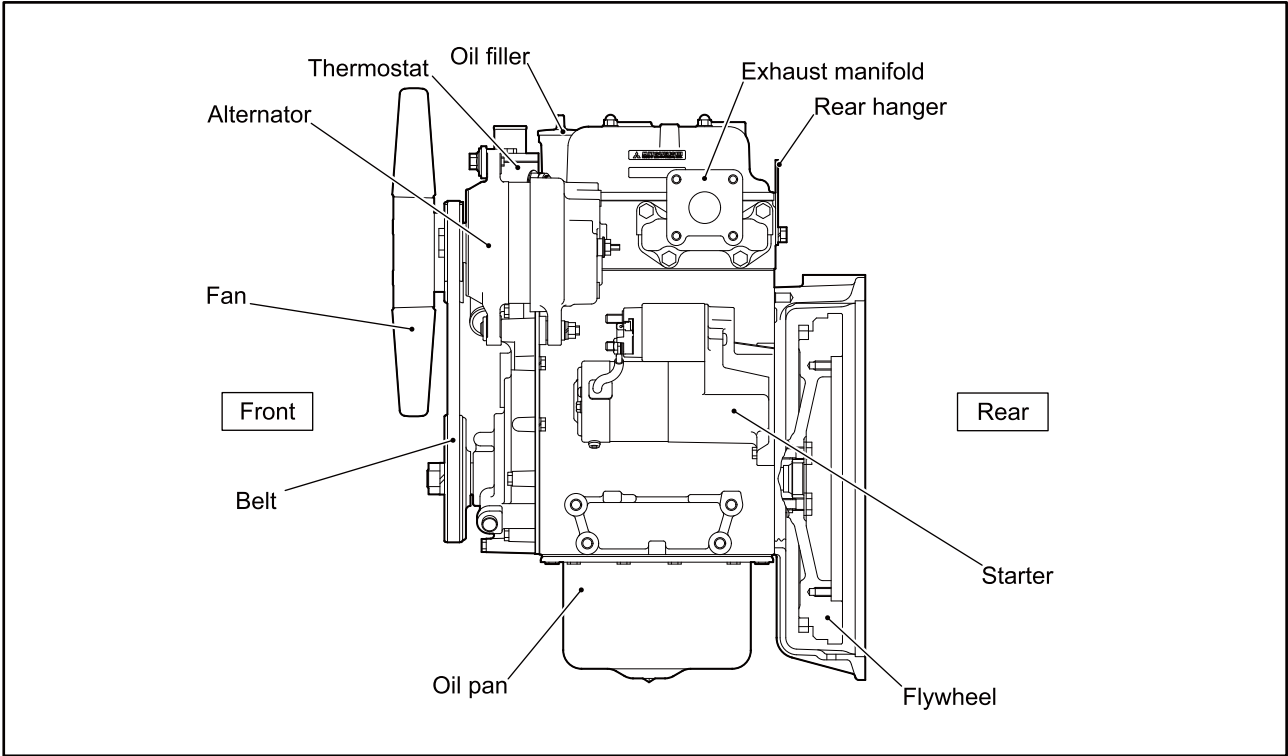

Fig. 2-1 Engine left view

### L2E right view

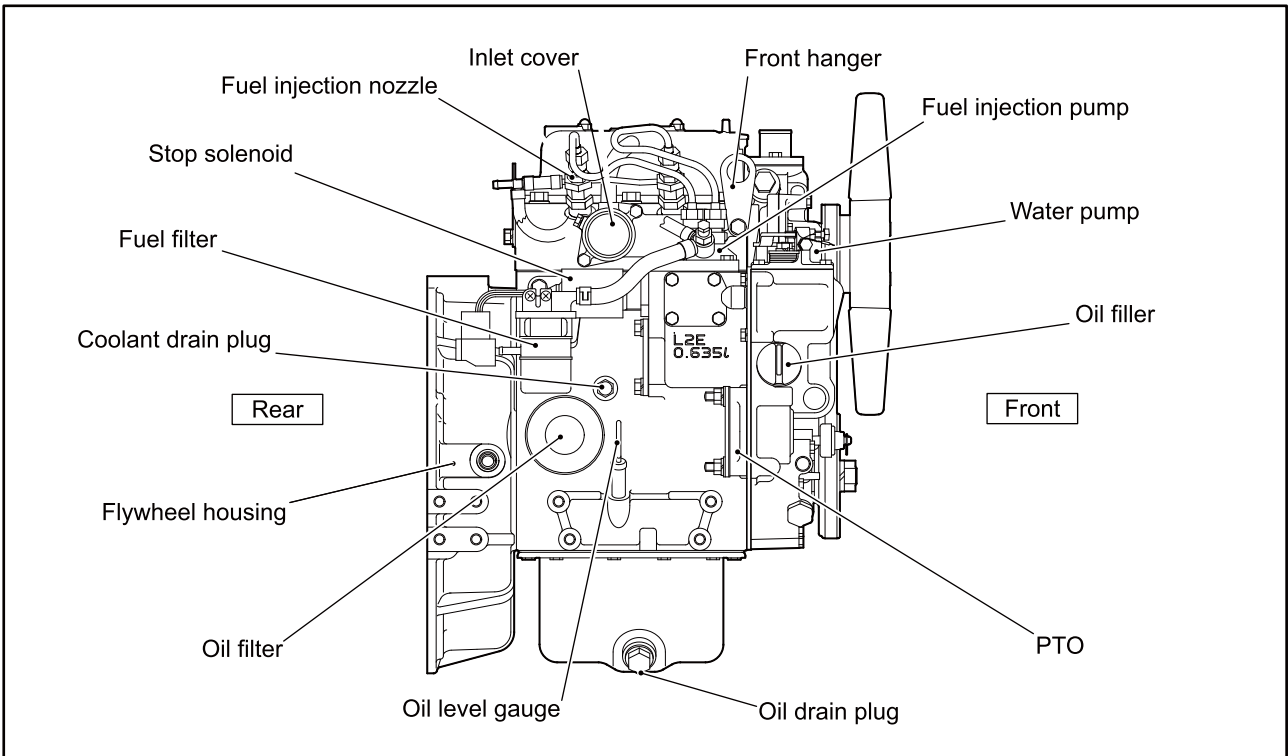

Fig. 2-2 Engine right view

### L3E left view

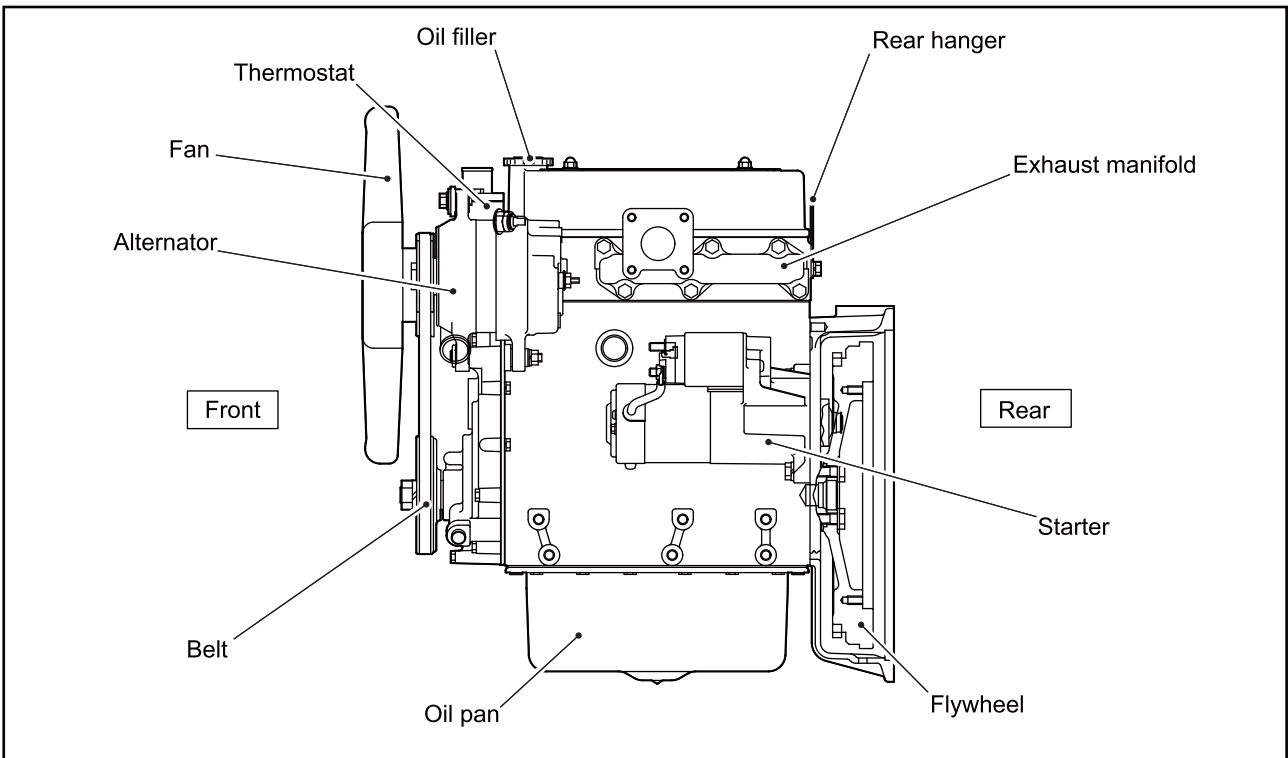

Fig. 2-3 Engine left view

### L3E right view

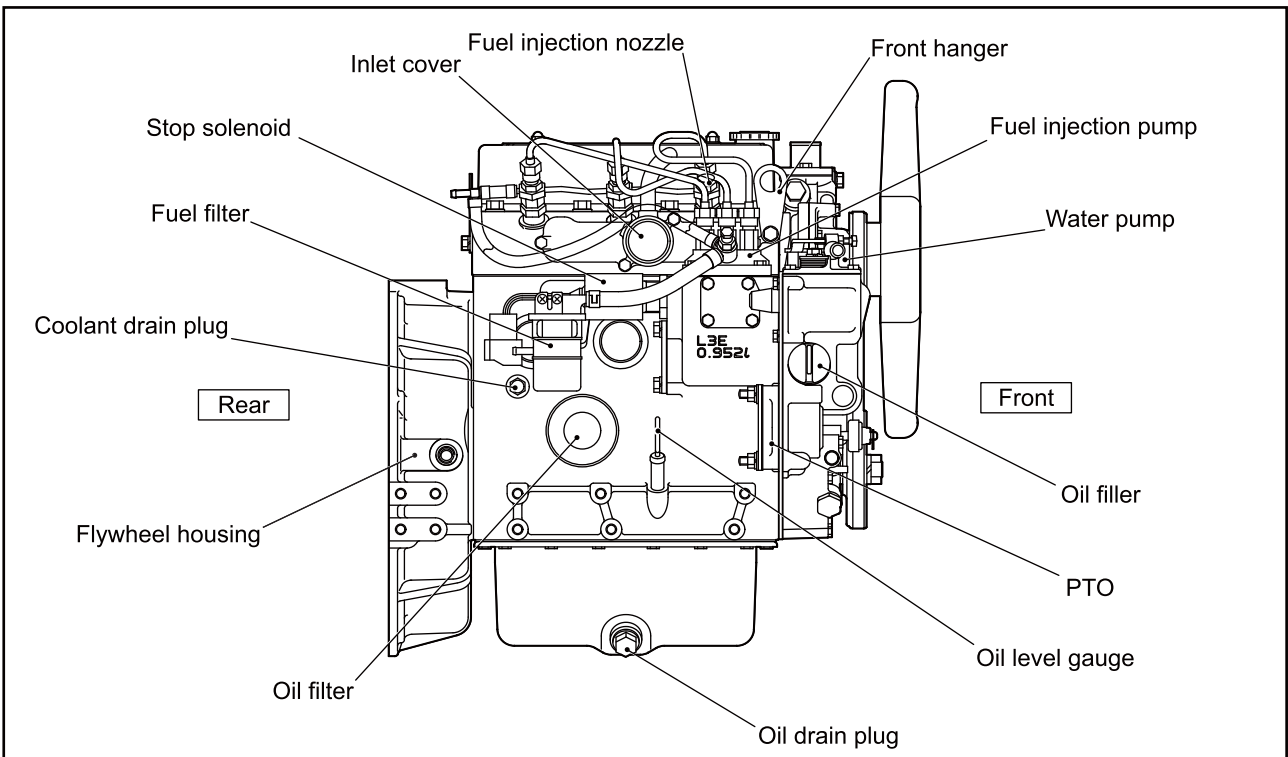

Fig. 2-4 Engine right view

## Equipment and instrument

The installed equipment and shapes differ on the engine type.

### Starter switch

The starter switch is used to start the engine.

#### HEAT

When the key is turned to this position, the glow plugs become hot and allow easy startup of a cold engine.

#### OFF

When the key is turned to this position, power supply to the electric circuits is cut off, and the key can be removed and inserted at this position. To stop engine, turn the key to this position.

#### ON

When the key is at this position, power is supplied to the electric circuits. After the engine starts, the key is set to this position.

#### START

When the key is turned to this position, the starter cranks the engine and the engine starts. When the key is released, it automatically returns to the "ON" position.

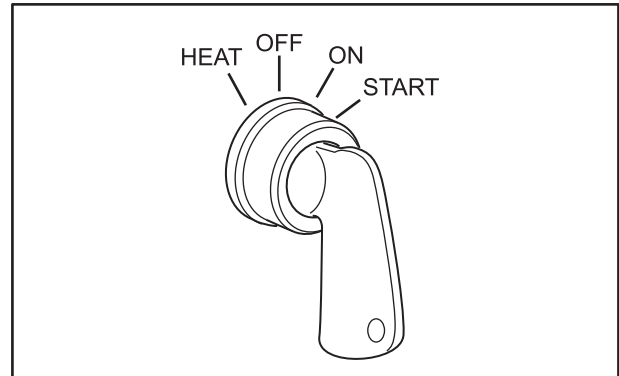

Fig. 2-5 Starter switch

### Preheat indicator

The preheat indicator shows the condition of the glow plugs.

#### Automatic glow type

The preheat lamp is on during the set periods of the glow timer, and off when the preheating is completed.

#### Manual glow type

The glow signal turns red to indicate the preheating condition as the glow plug is heated.

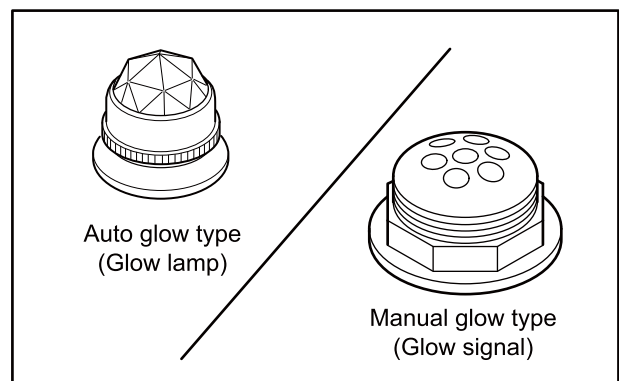

Fig. 2-6 Preheat indicator

## Water temperature meter and thermo unit

The engine coolant temperature detected by the thermo unit is displayed by the water temperature meter.

When the water temperature meter shows 95°C [203°F], idle the engine in low gear until the temperature becomes normal. After the temperature becomes normal, perform cooling operation for 5 or 6 minutes and then inspect the cooling system.

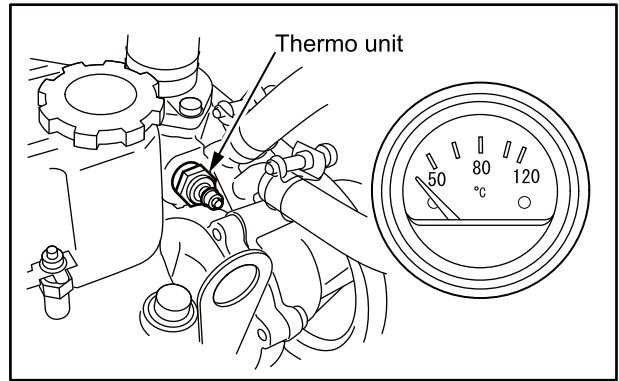

Fig. 2-7 Water temperature meter and thermo unit

## Ammeter

It indicates the battery charging condition while the engine is running.

When the battery is charged, the pointer swings to the positive (+) side. When the battery is discharged, the pointer swings negative (-) side.

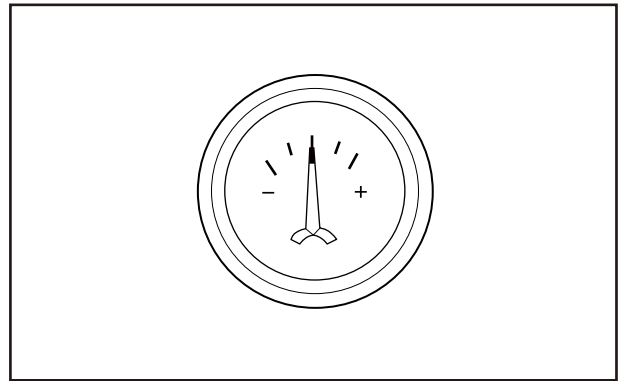

Fig. 2-8 Ammeter

## Hour meter

It indicates the operating time of the engine.

When performing the periodic inspection and maintenance, check the time interval with this meter.

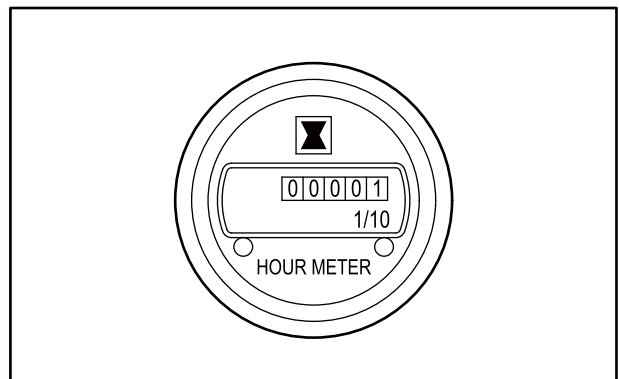

Fig. 2-9 Hour meter

## Stop solenoid

The stop solenoid operates for normal shutdown of engine operation.

The stop solenoid moves the rack of fuel injection pump to cut the fuel, and consequently stops the engine.

Two types of stop solenoids are available.

### **RUN OFF (ETS: Energized To Stop) type**

Not energized while the engine is running. Energized by a stop signal to stop the engine.

### **RUN ON (ETR: Energized To Run) type**

Energized while the engine is running, and de-energized to stop the engine.

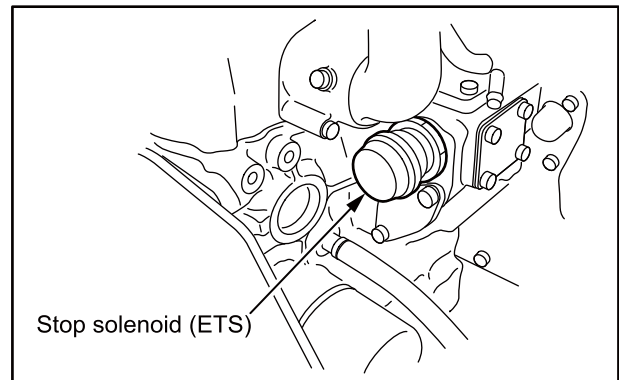

Fig. 2-10 Stop solenoid

## Engine protection devices

The engine protection device is a device to prevent the engine from the accident by generating the alarm when abnormality occurs. Stop the engine if the protection device is activated, investigate the cause of abnormality and restore it. When the cause of abnormality is unknown, contact a dealer of Mitsubishi Heavy Industries, Ltd. The installed protection devices, type (set value) or shapes varies according to the specifications.

### Oil pressure switch

The oil pressure switch activates the alarm system or stops the engine suddenly when the engine oil pressure becomes abnormally low.

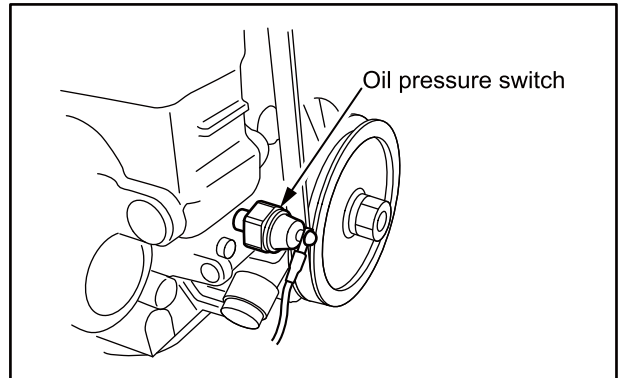

Fig. 2-11 Oil pressure switch

### Thermo switch

The oil pressure switch generates an alarm when the engine coolant temperature becomes high and reaches the specified temperature.

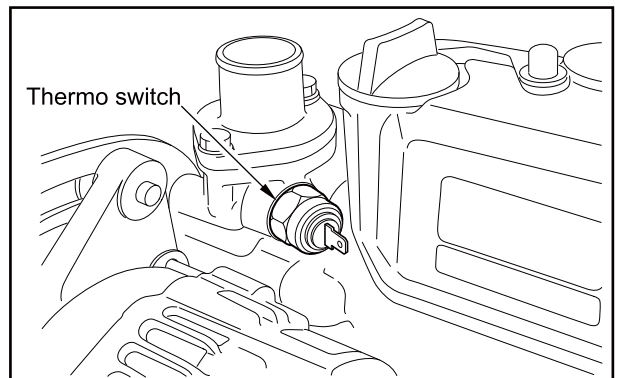

Fig. 2-12 Thermo switch

### Air cleaner indicator

The air cleaner indicator alarms with its red signal when air cleaner elements become clogged, the difference in pressure between front air cleaner and rear air cleaner, and reaches the specified value. The signal indicates only, and does not generate an alarm, Therefore, the periodic visually inspection is needed. Press the reset button on the top of air cleaner indicator and restore the signal after cleaned the air cleaner indicator or replaced with a new one.

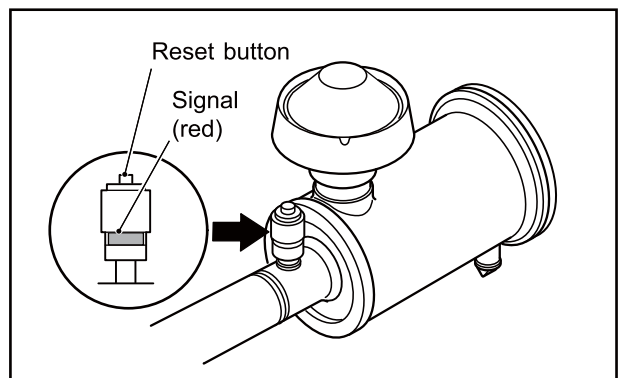

Fig. 2-13 Air cleaner indicator

# Chapter 3 OPERATION

## Preparations for operation

### ⚠ CAUTION

Should an engine abnormality be observed during operation, stop the engine and correct the problem, or contact a dealer of Mitsubishi Heavy Industries, Ltd.

Always conduct the following inspection before starting the engine.

## Engine external - Inspect

### ⚠ CAUTION

Be sure to keep combustible materials away from the engine, especially from the hot engine parts such as exhaust manifolds, or the battery. Check for fuel and oil leakage. Clean the top surface of the battery. A fire can be caused by combustible materials placed near hot engine parts. If any abnormality is found, be sure to repair it or contact a dealer of Mitsubishi Heavy Industries, Ltd.

Inspect the engine exterior as described below.

1. Make sure there is no combustible material near the engine or battery. Also, check to make sure that the engine and battery are clean. If combustible materials or dust are found near the engine or battery, remove them.
2. Check the electrical wiring for such components as the starter and alternator for looseness.
3. Check the entire engine for fuel leakage, engine oil or coolant. If leakages are found, repair or contact a dealer of Mitsubishi Heavy Industries, Ltd.
4. Make sure the following valves, plugs and cocks are open or closed (tightened) properly:
  - Fuel feed valve: Open
  - Coolant drain cock (plug): Closed (Tightened)
  - Oil drain valve: Closed

## Battery electrolyte level - Inspect

### ⚠ CAUTION

If battery electrolyte is spilled on your skin or clothes, flush immediately with plenty of water. If battery electrolyte get into your eyes, flush them immediately with plenty of water and then get medical attention.

Do not use open flames or other fire hazards near the battery. When handling the battery, be careful of sparks generated by accidental shorting. For other cautions in handling the battery, refer to "Service battery" (1-6).

Battery electrolyte evaporates during use and the electrolyte level gradually decreases. Proper electrolyte surface level is between the "LOWER LEVEL" and "UPPER LEVEL" lines.

For the battery without level lines, proper electrolyte surface level is about 10 to 15 mm [0.394 to 0.591 in.] above the top of the plates.

If the electrolyte level is low, remove the caps and add distilled water to the proper level.

Note: When adding distilled water, pour in carefully.

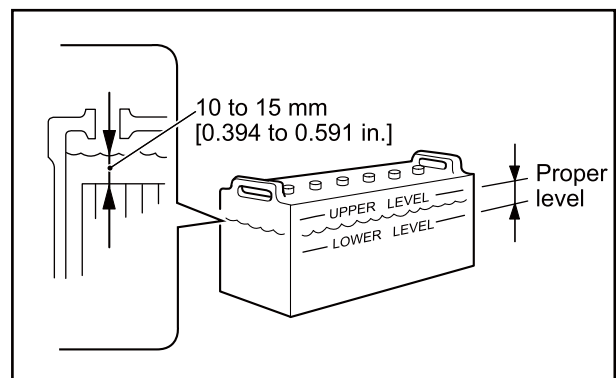

Fig. 3-1 Battery electrolyte level - Inspect

## Fuel tank oil level - Check

**WARNING**

When working around fuel, make sure there are no open flames, heaters or other fire hazards.  
Wipe off any spilled fuel completely. Spilled fuel can ignite and cause a fire.

**CAUTION**

Do not remove the strainer when filling the fuel tank.  
For fuel to be used, refer to "FUEL" (4-1).

Make sure the fuel tank is full.  
If the fuel level is low, refill the tank to the "FULL" level line.

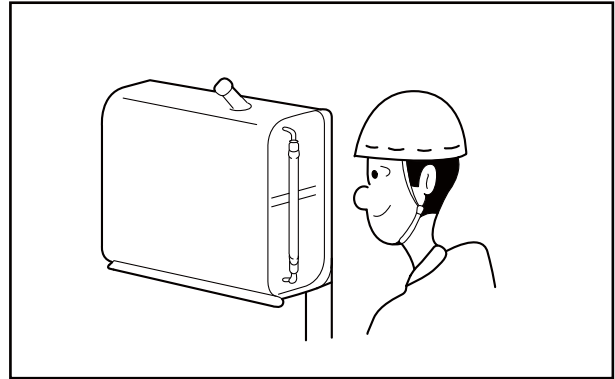

Fig. 3-2 Fuel tank oil level - Check

## Engine oil level - Check

**CAUTION**

For engine oil to be used, refer to "ENGINE OIL" (5-1).

1. Pull out the oil level gauge and wipe it clean using a waste cloth.
2. Insert the oil level gauge fully into the oil level gauge guide, then pull out the gauge again.
3. The proper oil level is between the high and low marks on the oil level gauge. If the oil level is low, add engine oil of the specified type.
4. Install the oil filler cap after refilling.
5. Check the oil pan and other area for oil leakage.

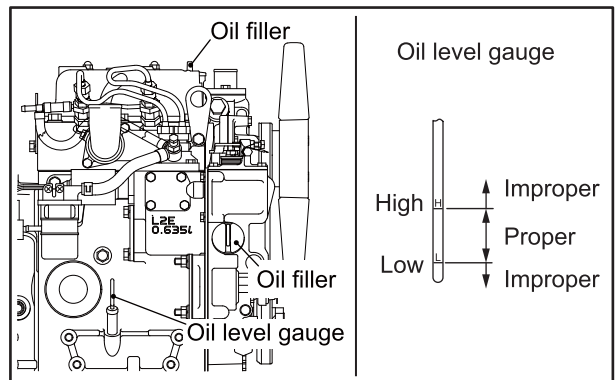

Fig. 3-3 Oil filler and Oil level gauge

## Coolant level - Check

### **WARNING**

Remove the radiator filler cap only after the engine has cooled to room temperature. Place a waste cloth over the cap, and loosen the cap about a half-turn or stand the lever to the upright position to release internal pressure. Never open the radiator filler cap while the engine is hot, otherwise the steam or hot coolant spurts out and you may be scalded with it.

1. Open the radiator filler cap and check the coolant level.
2. If the coolant level is low, add coolant to the specified level.

### **CAUTION**

Always use the coolant with the same LLC concentration.

Note: Determine the quantities of LLC based on the coolant capacity and the LLC concentration chart.

For the coolant, refer to ["COOLANT" \(6-1\)](#). For the coolant capacity, refer to ["MAIN SPECIFICATIONS" \(12-1\)](#).

3. If a reserve tank is equipped, fill the reserve tank with coolant up to the "FULL" level line.

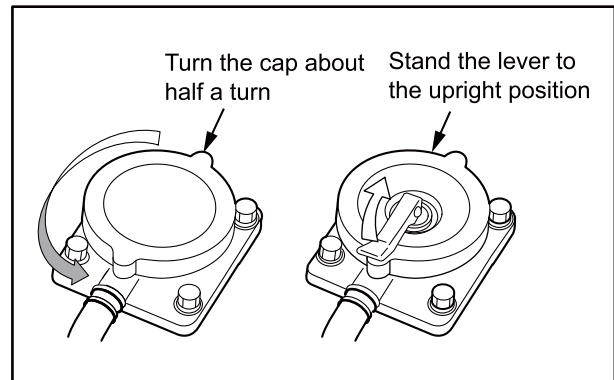

Fig. 3-4 Radiator filler cap

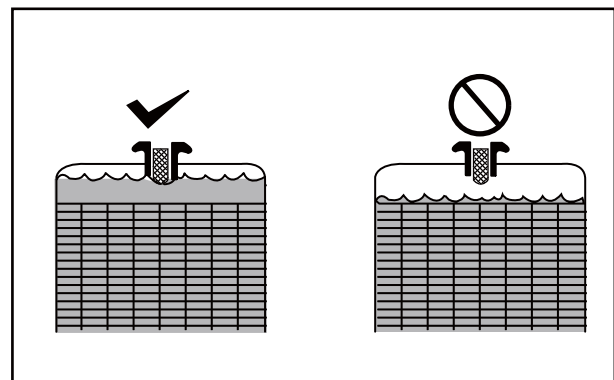

Fig. 3-5 Radiator coolant level

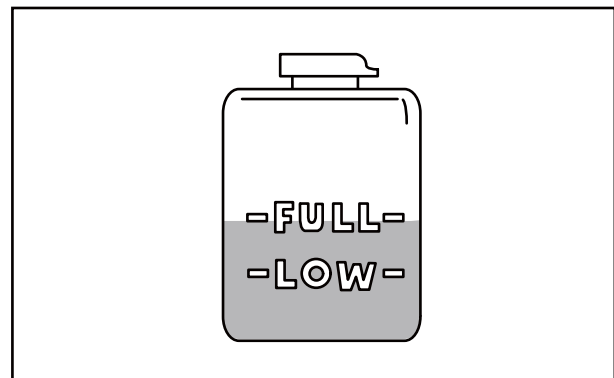

Fig. 3-6 Reserve tank coolant level

# Starting

The starting method changes based on the application and specifications. Start the engine according to the specified procedure.

**⚠ WARNING**

Before starting the engine, check to make sure no one is near the engine and that tools are not left on or near the engine. In a loud voice, notify people in the area when starting the engine.

**CAUTION**

Do not apply a load to the engine at starting. (Disengage the clutch if installed.)

Continuous operation of the starter will drain the battery power and cause the starter to seize. Do not use the starter for more than 10 seconds at a time. When the engine does not start, wait for more than 1 minute before cranking again.

When preheating, do not heat over 30 seconds at a time (For manual glow plug). Otherwise the battery capacity reduce in a short time or decrease glow plug life.

## Automatic glow plug

1. Turn the starter key to "ON" position. Confirm the oil pressure lamp, water temperature lamp, battery charge lamp and preheat lamps turn on at the time. The preheat lamp lighting duration is as follows:

Note: When the engine is cold, move the speed control lever to "FULL" position and turn the starter switch key to "ON" position.

Table 3-1 Preheat duration (automatic glow plug)

Specifications	Water temperature	Preheat duration
Quick type (bimaterial)	Low water temperature (5°C [41°F] or below)	Approx. 3 seconds
	High water temperature (5°C [41°F] or above)	Approx. 1 seconds
Standard type	Any time	Approx. 6 or 10 seconds

2. After the preheat lamp goes off, turn the starter key to "START" position and start up the engine. The preheat lamp turns on at "START" position as well.
3. Release your hand from the key when the engine starts up. The key returns to "ON" (operating) position automatically.

## Manual glow plug

1. Turn the starter key to "HEAT" position. The preheat duration is as follows;

Table 3-2 Preheat duration (manual glow plug)

Ambient temperature	Preheat duration
+5°C [41°F] or higher	Approx. 10 seconds
-5°C [23°F] or higher, less than +5°C [41°F]	Approx. 15 seconds
less than -5°C [41°F]	Approx. 20 seconds

2. After the preheat lamp glows, turn the starter key to "START" position and start up the engine.
3. Release your hand from the key when the engine starts up. The key returns to "ON" (operating) position automatically.

---

## Warm up operation

---

 **WARNING**

Do not approach rotating parts during operation. Entanglement by rotating parts can cause serious injury.

After the engine starts, operate the engine in a no load condition at low idling speed for 5 to 10 minutes to warm up the engine.

### Checking engine oil pressure

During warm up operation, check if the oil pressure is in the range of standard value (0.15 MPa {1.5 kgf/cm<sup>2</sup>} [21 psi] or more).

Also, make sure the oil pressure gauge is operating properly.

Note: The oil pressure gauge may indicate a higher level than normal level immediately after the engine starts, due to the low oil temperature. The pressure gradually lowers to the normal level as the oil temperature rises.

### External inspection during warm up

Visually check the external view of the engine for fuel, engine oil and coolant leakage, or exhaust gas leakage from joints.

# Operation

## Cautions when operating

**⚠ WARNING**

Do not approach rotating parts during operation. Entanglement by rotating parts can cause serious injury.

**⚠ CAUTION**

Do not touch any hot part of the engine such as exhaust pipes during operation or immediately after shut down. A hot engine can cause burns.

**CAUTION**

Always provide adequate ventilation in the engine room. If air supply to the engine room is not sufficient, the room temperature rises and can affect engine output and performance.

For the first 50 hours, operate the engine under a light load for break-in operation. Operating the engine under heavy load or severe conditions during the break-in period can shorten the service life of the engine.

Do not turn the battery switch to "OFF" position when the engine is running. Turning off the battery switch during operation not only stops the instrument operations but also may deteriorate the alternator diode and regulator.

Never turn the key to the "START" position during operation. The starter may be damaged.

When operating the engine with a 30 % of rated load or lower, limit each operation to an hour. Prolonged warm up operation causes carbon build-up in the cylinders that leads to incomplete combustion. Operate the engine with a 30 % of rated load or more for over 5 minutes after continuous operation for an hour to prevent causing carbon build-up.

## Inspection during operation

Carefully check the exterior of engine such as piping joints for leaks.

Check for abnormal engine noises or vibrations such as knocking.

Check the color of exhaust gas from the exhaust muffler.

Check the instruments and gauges for proper operation and make sure they indicates normal values.

Table 3-3 Standard values at rated speed

Item	Standard
Engine oil pressure	0.29 to 0.49 MPa {3 to 5 kgf/cm <sup>2</sup> } [43 to 71 psi]
Coolant temperature	70 to 90°C [158 to 194°F]

Note: (a) When the oil pressure drops below 0.15 MPa {1.5 kgf/cm<sup>2</sup>} [21 psi] in normal operation, or below 0.05 MPa {0.5 kgf/cm<sup>2</sup>} [7 psi] at low idling, stop the engine immediately.

Be sure to locate the cause of problem and correct it before restarting the engine.

(b) When the thermo switch is activated in normal run, idle the engine in low gear immediately until the engine temperature becomes normal. Then, perform cooling operation for 5 or 6 minutes before stopping the engine. Be sure to locate the cause of problem and correct it before restarting the engine.

---

## Stopping

---

**⚠ CAUTION**

---

Stopping the engine abruptly while engine parts are hot due to high-speed operation can be a cause for heat up of the engine parts and shorten the engine life. Before stopping the engine, idle the engine in low gear immediately until the engine temperature becomes normal except in an emergency. Then, perform cooling operation for 5 or 6 minutes before stopping the engine and inspect the whole engine.

Never accelerate the engine immediately before shutting it down.

Do not restart the engine immediately after abnormal shut down. When the engine stops with alarms, be sure to locate the cause of the problem and correct the problem before restarting the engine. After restarting the operation, inspect the whole engine for any abnormalities again. If the engine has an abnormality, repair it immediately.

---

Engine stopping method may differ depending on the specifications.

Follow the instructions according to the specifications of the equipment.

### Inspection after stopping

Inspect the engine for fuel, oil or coolant leakage. If any leakage is found, repair the leakage or contact a dealer of Mitsubishi Heavy Industries, Ltd.



## Recommended fuel

**WARNING**

Use a fuel specified in this manual only. Do not refill the fuel tank more than the specified level, as it may result in a fire.

Use a diesel fuel equivalent for "JIS K 2204 diesel fuel".

It is necessary to use a fuel that has a pour point suitable for the ambient temperature.

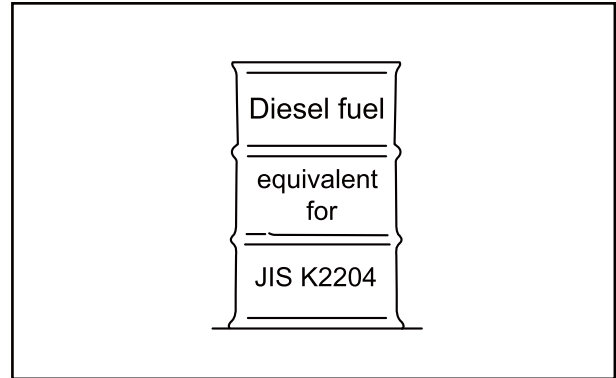

Fig. 4-1 Recommended fuel

## Handling fuel

When using fuel stored in a storage tank, leave it to sit for more than 24 hours so that dust and water can settle at the bottom. Then, use the upper clean fuel.

Fill up the fuel tank or service tank after each operation.

This prevents water from mixing with fuel in the tank and also gives time for dust and water to separate and settle at the bottom of the tank.

Before refilling, clean the areas around the caps thoroughly and remove the caps from the drum and tank. Also clean your hands and the hose before refueling. When using a hand-operated pump, be careful not to pump water or sediment accumulated at the bottom of the storage tank.

Be sure to use a strainer when filling fuel tank. For a complete filtration, it is recommended to use a clean lint-free cloth together with the strainer.

Table 4-1 Recommended limit and use limit of fuel property

Properties		Recommended limits	Use limits	Test method
Flash point		50°C [122°F] or higher	45°C [113°F]	JIS K 2265:2007 ISO 3769 ISO 2719
Distillation	Initial boiling point	170°C [338°F] or higher		JIS K 2254:1998 ISO 3405
	90 % distillate temperature	330 to 380°C [626 to 716°F]		
Pour point (PP)		6°C [42.8°F] or lower than ambient temperature		JIS K 2269:1987 ISO 3016
Cloud point (CP)		Below ambient temperature		JIS K 2269:1987 ISO 3015
Cold filter plugging point (CFPP)		3 °C [37.4 °F] or lower than ambient temperature		JIS K 2288:2000 IP 309/96
Carbon residue (10 % bottom oil)		0.1 weight % or lower	0.4 weight % or lower	JIS K 2270:2000 ISO 6615 ISO 10370
Cetane number		45 or higher	40 or higher	JIS K 2280:1996 ISO 5165
Cetane index (new type)		45 or higher	40 or higher	JIS K 2280:1996 ISO/DIS 4264
Kinematic viscosity		2.0 mm <sup>2</sup> /s [0.0031 in <sup>2</sup> /s] or more at 30 °C [86 °F] 8.0 mm <sup>2</sup> /s [0.0124 in <sup>2</sup> /s] or more at 30 °C [86 °F]		JIS K 2283:2000 ISO 3104
Sulfur content		0.2 weight % or lower (Except in cases the value is specified by the emission control.)		JIS K 2541:2003 (The content should be as low as the diesel fuel.) ISO 4260 ISO 8754
Water content and sediment		0.1 volume % or lower		JIS K 2275:1996 ISO 3733
Ash content		0.01 % by mass or less	0.03 weight % or lower	JIS K 2272:1998 ISO 6245
Copper corrosion (3 hrs at 50 °C [122 °F])		Color change = Copper plate No.3 or less		JIS K 2513:2000 ISO 2160
Density at 15 °C [59 °F]		0.83 to 0.87 g/cm <sup>3</sup> [49.9424 to 54.3123 lb/ft <sup>3</sup> ]	0.80 to 0.87 g/cm <sup>3</sup> [49.9424 to 54.3123 lb/ft <sup>3</sup> ]	JIS K 2249:1995 ISO 3675
Caulking	24 hrs at 250 °C [482 °F]	75 % carbonization or less	80 % carbonization or less	Fed 791B
	24 hrs at 230 °C [446 °F]	55 % carbonization or less	-	
	48 hrs at 180 °C [356 °F]	Tar-free	-	
Aromatics substances (by HPLC)		35 % by volume or less (total of aromatic components)		JIS K 2536:2003 ISO 3837
Polycyclic aromatic content		8 % by volume or less		JIS K 2536:2003 IP 391
Asphaltene		0.1 weight % or lower		-

Table 4-1 Recommended limit and use limit of fuel property

Properties	Recommended limits	Use limits	Test method
Foreign materials (foreign materials at engine fuel inlet)	5.0 mg/liter or less		JIS B 9931:2000 ISO 4405
Lubricity: MWSD (Measured mean Wear Scar Diameter) by HFRR wear test at 60 °C [140 °F] fuel temperature	460 μm [0.02 in.] or less (calculated wear scar diameter at WS 1.4 kPa {0.0143 kgf/cm <sup>2</sup> } [0.2031 psi])		ISO 12156-1
BDF: Biodiesel fuel (FAME: Fatty Acid Methyl Ester)	BDF quality shall meet JIS K 2390, EN14214, or ASTM D6751 BDF blending of 5 % by volume or less is approved (Except in cases the value is specified by the emission control.)		JIS K 2390:2008 (FAME for mixture) ASTM D 6751 EN 14214

Note: When using fuel less than use limits, white smoke, worsening start up or unstable rotation may occur.



# Chapter 5 ENGINE OIL

## Recommended engine oil

### CAUTION

Use only the engine oils recommended in this manual. Never use other oils.

The use of inappropriate or inferior oils will result in sticking of piston rings, seizure between piston and cylinder, or premature wear of bearings and moving parts, and significantly shortens the service life of the engine.

Many oil standards, which are established through special engine tests, are available to determine the quality of oil depending on the engines to which they will be applied and on operating conditions. Among those standards, API (American Petroleum Institute) service classifications are mostly used to classify engine oils. SAE specifies the viscosity only, while the API service classification indicates the quality level of engine oil.

For engine lubrication oil, please use API service classification CF.

### Selection of oil viscosity

Use the following chart to select the appropriate oil viscosity according to the ambient temperature.

Excessively high oil viscosity causes power loss and an abnormal rise of oil temperature, while excessively low oil viscosity accelerates wear due to inadequate lubrication, and also causes a decrease in engine output due to leakage of combustion gas.

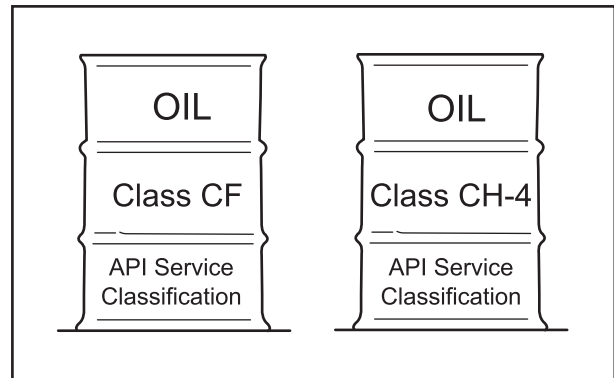

Fig. 5-1 Recommended engine oil

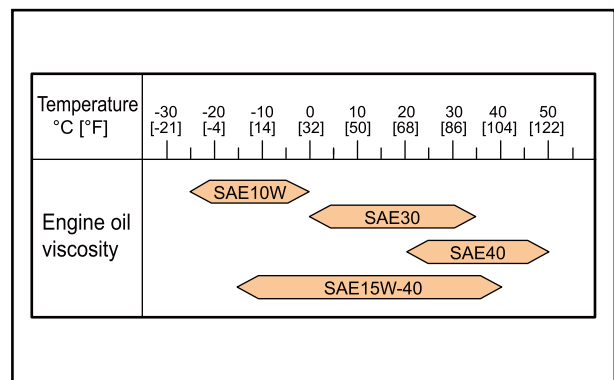

Fig. 5-2 Selection of oil viscosity

## Handling engine oil

### WARNING

Before filling the engine with engine oil, stop the engine and make sure there are no open flames and other fire hazards near the engine. Leaked or spilled oil on hot surfaces or electrical components can cause a fire. Wipe off any spilled oil immediately and thoroughly. After filling, securely close the filler cap.

### CAUTION

Never mix different brands of engine oil. Mixing different brands of engine oil may cause a chemical reaction of additives in the engine oil that could degrade the engine oil quality.

When handling oil in greater than the legally specified quantities, be sure to have the work performed by a service station in compliance with the law. When removing oil from the engine or oil can, use an oil pump. Do not suck oil with the mouth to siphon it.

Be sure to close the cap on the oil can after use.

Keep oil in a well-ventilated area and out of direct sunlight.

Be sure to obtain the MSDS of the engine oil used and follow the instructions of the MSDS.

## Engine oil performance requirements

Engine oil requires the following performances.

- ♦Excellent dispersion performance (the ability of oil to disperse sludge in the oil) at high temperature that prevents engine oil deterioration due to sludge accumulation and soot contamination.
- ♦Excellent acid-neutralizing performance that prevents oxidative degradation due to fuel sulfur content.
- ♦Excellent high temperature oxidation stability that endures continuous operation under prolonged high-load.
- ♦Sufficient viscosity concentration to maintain the cold start performance, and lubrication performance at high temperature.
- ♦Good rust and corrosion resistance to water.
- ♦Good foam resistance to prevent the lubricating quality from lowering due to oxidation.

## Engine oil deterioration mechanisms

- ♦Engine oil deteriorates due to natural deterioration and due to the contamination. The natural deterioration of oil has two primary causes; one is the degradation caused by oxidation reaction or thermo decomposition of base oil and additives, and the other is the degradation in the performance due to consumption of additives during use.
- ♦Contaminants such as fuel and combustion products (soot, water vapor or oxidation products) that intrude into oil have critical influence on oil quality. Soot adheres to the oil film of cylinder wall, and is scraped off the cylinder wall by the piston ring. Such soot increases the rate of insoluble substances in the engine oil and can cause the wear of piston rings and cylinder walls.

- ♦Abrasion powder in the engine oil also accelerates deterioration as it can catalyze oxidation reaction. Dust and dirt entered from outside deteriorate the engine oil as well. Contamination and deterioration process accelerates with operation time.
- ♦Deterioration products and contaminants in the engine oil, if it is a small amount, are harmless as they can be dispersed in oil. However, if it is a large amount, they become harmful. Since such products and contaminants flow out of the oil pan and start to accumulate inside the piston and in the oil system, they eventually lead to serious problems such as piston ring sticking and bearing scuffing.
- ♦Sulfur content in fuel is burned and transformed into sulfurous acid gas and sulfuric gas that cause corrosive wear of cylinders and piston rings. A detergent additive in the engine oil neutralizes them into harmless substances. As the detergent additive is consumed in its role of neutralizing, the engine oil total base value decreases. A decrease in the total base value indicates a corresponding decrease in soot dispersion ability. As a result, deposits on the pistons increase.
- ♦Due to oxygen in the air, oil temperature rise under high-load continuous operation causes oxidation degradation. As oxidation degradation accelerates, oxidative products are polymerized. The polymerized oxidative products cause the oil viscosity to increase, which leads to the generation of sludge and varnish. As a result, problems such as lubrication failure and piston ring sticking occur. Also acid substances generated by oxidation can cause problems like main bearing corrosion.

## Definition of properties of engine oil

### Viscosity

Viscosity is a basic physical property of engine oil and is considered as the most important aspect when evaluating oil.

Contamination of oil by blow-by gas and deterioration of oil by its natural aging increase the viscosity and degrade the performance of viscosity, which will cause the deposition of sludge inside the engine and oil filter clogging. Contamination of oil by fuel and sheared molecules of viscosity index improver in oil decrease the viscosity and degrade the performance of viscosity, which will cause insufficient lubrication and friction/wear of engine parts.

### Total base number

Total base number (TBN) shows the ability to neutralize acids such as organic acid due to engine oil oxidation, or sulfurous or sulfuric acid due to the sulfur content of fuel.

Because TBN indicates the amount of dispersant detergent in oil, it can be used to estimate consumption of basic dispersant detergent. The ability to disperse sludge declines as dispersant detergent is used up.

### Total acid number

The total acid number in oil increases as the organic acid is being derived by the engine oil oxidation, or sulfurous acid or sulfuric acid derived by the combustion of sulfur content of fuel, or the oil becomes contaminated with imperfect combustion products.

An increase in the total acid number will result in corrosion or wear of the inner parts of the engine (such as cylinder liners or metal) due to sulfur content, and piston ring seizure due to sludge.

### Water content

Water in oil promotes corrosion/wear, and decreases lubricity in sliding parts.

### Flash point

The flash point is lowered by contamination with fuels. Flash point is measured to check the dilution of fuel. The dilution of fuel reduces oil film, and causes insufficient lubrication that will cause friction or wear of engine parts.

### Insoluble

Insoluble includes acid products of engine oil, imperfect combustion products, sludge or soot, metal abrasive particles and dust. Insoluble is an indication of degradation/contamination of oil.

Dispersant detergent, which is an additive in engine oil, absorbs sludge particles, and disperses them as fine particles in oil. Total insoluble density and remaining dispersibility can be obtained by measuring insoluble and coagulated insoluble (using chemical specialities to stop action of disperse detergent and to collect the sludge dispersed in oil) by which piston ring seizure or premature wear can be prevented before it occurs.

## Service Limits of engine oil

Engine oil degrades through the use and by lapse of time.

To determine the timing of engine oil replacement, analyze the used oil, and understand the condition of oil deterioration and oil defacement. It is also required to compare the oil analysis results and the engine analysis results including inside contamination and wear condition of engine, and to consider the engine operating condition.

The engine oil affects the engine oil quality to use, the engine operating condition and the quality of fuel. Analyze the used oil, and understand the condition of oil deterioration and oil defacement. To determine the timing of engine oil replacement, the stabiration of engine is required.

Refer to the following table for the determination of engine oil performance degradation. If any of the following deviate the limit, replace the engine oil with new oil.

Table 5-1 Engine oil properties

Properties		Standard	Test method
Viscosity	mm <sup>2</sup> /s [in <sup>2</sup> /s] @100°C [212 °F]	+30% or less -15% or more of new oil	JIS K 2283:2007 ISO 3107 ISO 2909
Total base number	mgKOH/g	2.0 or more with hydrochloric acid (HCL) method 1/2 of new oil or more with perchloric acid (PCA) method	JIS K 2501:2003 ISO 3771
Total acid number	mgKOH/g	Up to +3.0 of new oil	JIS K 2501:2003 ISO 3771
Water content	Vol %	0.2 or less	JIS K 2275:1996 ISO 9029
Flash point (open cup)	°C [°F]	180 [356] or higher	JIS K 2265:2007 ISO 3769 ISO 2719
Pentane insoluble	Wt %	0.5 or less	ASTM D 893
Pentane insoluble coagulated	Wt %	3.0 or less	ASTM D 893

# Chapter 6 COOLANT

Note: In this operation manual, the word "coolant" represents the liquid combined water and LLC.

## Recommended water for coolant

Use soft water for the engine cooling system. The water quality must meet the requirements in the Table below. Basically, the water quality should be within the recommended value, however, up to the limit is acceptable.

Table 6-1 Water quality standards

Item	Chemical symbol	Unit	Recommend value	Limit	Main adverse effect
pH (25 °C [77 °F])	-	-	6.5 to 8.0	6.5 to 8.5	Corrosion and rust, scale formation
Electrical conductivity (25 °C [77 °F])	-	mS/m	< 25	< 40	Corrosion and rust, scale formation
Total hardness	CaCO <sub>3</sub>	ppm	< 95	< 100	Scale formation
M alkalinity	CaCO <sub>3</sub>	ppm	< 70	< 150	Scale formation
Chlorine ion	Cl <sup>-</sup>	ppm	< 100	< 100	Corrosion and rust
Sulfuric acid ion	SO <sub>4</sub> <sup>2-</sup>	ppm	< 50	< 100	Corrosion and rust
Total iron	Fe	ppm	< 1.0	< 1.0	Scale formation
Silica	SiO <sub>2</sub>	ppm	< 30	< 50	Scale formation
Residue from evaporation	-	ppm	< 250	< 400	Scale formation

Note: Figures in parentheses are the standard value. In addition to the items specified above, turbidity is specified to be below 15 mg/liter.

## Long life coolant (LLC)

### ⚠ CAUTION

Should coolant or LLC be accidentally consumed, induce vomiting immediately and seek medical attention. If LLC should enter eyes, flush immediately with plenty of water and seek medical attention.

Be sure to use Mitsubishi Heavy Industries, Ltd. genuine long life coolant (LLC) "GLASSY long life coolant (Ethylene glycol type)" or "PG GLASSY long life coolant (Non-amine type)" as coolant. When using other brand LLCs by necessity, be sure to use the LLC that meets the specification in Mitsubishi Heavy Industries, Ltd. Mitsubishi heavy industries, Ltd. disclaim the warranty claim concerning malfunctions caused by the use of LLC that does not meet the following specification.

## Genuine LLC

Mitsubishi Heavy Industries, Ltd. recommends the use of our genuine long life coolant "GLASSY long life coolant (Ethylene glycol type)", and Eco-friendly product "PG GLASSY long life coolant (Non-amine type)", which are most appropriate coolant for diesel engine from Mitsubishi Heavy Industries, Ltd.

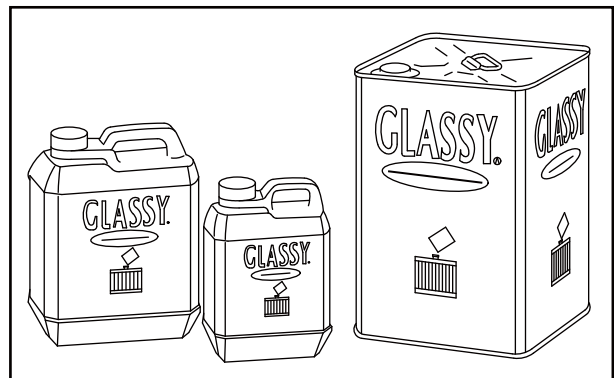

Fig. 6-1 GLASSY - LLC

## Other brand LLCs

### CAUTION

Never mix Mitsubishi Heavy Industries, Ltd. genuine LLC with other brand LLCs. Mixing with other brand LLCs degrades the performance of Mitsubishi Heavy Industries, Ltd. genuine LLC.

When using LLC other than Mitsubishi Heavy Industries, Ltd. genuine long life coolant (LLC) "GLASSY long life coolant (Ethylene glycol type)" or "PG GLASSY long life coolant (Non-amine type)", be sure to use the LLC which meets specification in Mitsubishi Heavy Industries, Ltd.

The quality and performance of commercially available LLCs as well as their component variations are the responsibility of LLC suppliers.

Before purchasing commercial LLC, be sure to discuss the suitability of LLC with the LLC supplier.

Use only all-season LLC (non-amine type). Do not use antifreeze alone instead of LLC.

## Standard for other brand LLC

When using other brand LLCs by necessity, be sure to use the LLC that meets following specification. Mitsubishi heavy industries, Ltd. disclaim the warranty claim concerning malfunctions caused by the use of LLC that does not meet the following specification.

### General demands of LLC

- ♦ LLC shall be a homogeneous liquid.
- ♦ Engine cooling system shall not receive troubles such as corrosions and precipitation products etc. by LLC when the LLC is diluted to 30 to 60 % density.
- ♦ LLC shall be mixed with other LLC that satisfies this specification, and shall not separate elements each other, and shall not decrease the performance each other.
- ♦ LLC shall not allow the container to be corroded, and shall not has precipitation products etc. even if LLC is left in the container for 6 months.
- ♦ LLC shall not has extraction products etc. even if LLC is kept in -20 to -25°C [-4 to -13°F]
- ♦ The validity term of the quality that provides with this specification is 2 years after it delivers with the indoor normal temperature keeping.

## LLC specification

LLC shall examine according to JIS K2234 section 7 (examination methods), and satisfy this specification. General matters and the sample to the examination is shown in JIS K2234.

Table 6-2 LLC specification

Property		Standard		
External		Not precipitation		
Density		Minimum 1.112 g/cm <sup>3</sup> [69.4199 lb/ft <sup>3</sup> ] (20/20 °C) [68/68 °F] (Stock solution)		
Water content		Maximum 5.0 weight % (Stock solution)		
Frozen temperature	30 vol %	Maximum -14.5 °C [6 °F]		
	50 vol %	Maximum -34.0 °C [-29 °F]		
Boiling temperature		Minimum 155 °C [311 °F] (Stock solution)		
pH		7.0 to 11.0 (30 vol %)		
Bubbling character (ASTM D 3306-01)	30 vol %	Maximum 4.0 ml		
	33 <sup>1</sup> / <sub>3</sub> vol %	Maximum 150 ml, Disappearance of bubble within 5 sec.		
Hard water adaptability		Maximum 1.0 (50 vol %)		
Metallic causticity (88±2°C [190±36°F], 336±2 Hr, 30 vol % (E.G), 50 vol % (P.G))	Test piece	Mass change	Aluminum	±0.30 mg/cm <sup>2</sup>
			Cast iron	±0.15 mg/cm <sup>2</sup>
			Steel	±0.15 mg/cm <sup>2</sup>
			Brass	±0.15 mg/cm <sup>2</sup>
			Solder	±0.30 mg/cm <sup>2</sup>
			Copper	±0.15 mg/cm <sup>2</sup>
			External of test piece after the examination	Not corrosion on surface excluding between test piece and spacer. Discoloration is OK.
			Bubbling while examination	Not bubbling overflow
	Properties of liquid after the examination	pH		6.5 to 11.0
		pH change		±1.0
Precipitation		Maximum 0.5 vol %		
External of liquid		Not remarkable discoloration, separation and gel.		
Circulation metallic causticity (98±2°C [208±36°F], 1000 Hr, 30 vol % (E.G), 50 vol % (P.G))	Test piece	Mass change	Aluminum, Cast iron, Steel, Brass, Solder, Copper	±0.30 mg/cm <sup>2</sup>
			External of test piece after the examination	
	Properties of liquid after the examination	pH		7.0 to 9.0
		pH change		±1.0
		Pre-alkalinity change		±15 %
		Precipitation		1.0 vol %
		External of liquid		Not remarkable discoloration, separation and gel.
		Density of ion	Fe, Cu, Al, Zn, Pb, NH <sub>4</sub> <sup>+</sup>	Maximum 10 ppm

Table 6-2 LLC specification

Property			Standard	
Circulation metallic causticity (88±3°C [190±37°F], 1000±2 Hr, 30 vol % (E.G))	Test piece	Mass change	Aluminum	±0.60 mg/cm <sup>2</sup>
			Cast iron	±0.30 mg/cm <sup>2</sup>
			Steel	±0.30 mg/cm <sup>2</sup>
			Brass	±0.30 mg/cm <sup>2</sup>
			Solder	±0.60 mg/cm <sup>2</sup>
			Copper	±0.30 mg/cm <sup>2</sup>
		External of test piece after the examination	Not corrosion on surface excluding between test piece and spacer. Discoloration is OK.	
	Properties of liquid after the examination	pH	6.5 to 11.0	
		pH change	Maximum ±1.0	
		External of liquid	Not remarkable discoloration, separation and gel.	
Condition of parts	Pump seal	Not trouble while the examination		
	Inside of pump case and blade	Not remarkable corrosion		
Rubber adaptability (30 vol %, 115°C [239°F], 360 Hr)	Silicon	Tensile strength change	-60 to 0 %	
		Elongation change	-40 to +20 %	
		Volume change	0 to +40 %	
		Hardness change	-20 to +10 %	
	Acrylonitrile butadiene rubber	Tensile strength change	0 to +10 %	
		Elongation change	-15 to +15 %	
		Volume change	0 to +40 %	
		Hardness change	-10 to 0 %	
	Ethylene propylene diene monomer	Tensile strength change	0 to +10 %	
		Elongation change	-30 to 0 %	
		Volume change	0 to +10 %	
		Hardness change	-10 to 0 %	
	Storage stability vol % (30 vol %, room temperature, 6 Hr)			Maximum 0.3

## Maintenance of LLC

### ⚠ CAUTION

Should coolant or LLC be accidentally consumed, induce vomiting immediately and seek medical attention. If LLC should enter eyes, flush immediately with plenty of water and seek medical attention.

LLC is toxic. Never dispose of coolant containing LLC drained from engine into regular sewage. For disposal of used coolant, consult LLC distributor.

## Replacement intervals of LLC

### CAUTION

Be sure to renew LLC at the intervals specified in the maintenance schedule of this manual.

Failure to renew LLC may cause malfunctions due to performance degradation of preventing rust and cavitation.

The coolant mixed with LLC which Mitsubishi Heavy Industries, Ltd. recommended expires in 2 years. Be sure to change coolant at least once every 2 years.

## LLC concentration

Keep the LLC concentration of 30 % (GLASSY) and 40 % (PG GLASSY) on any temperature conditions. LLC of less than 30 % concentration does not provide sufficient corrosion protection. If the LLC concentration is lower than 10 %, it may accelerate corrosion.

When adding coolant, do not add plain water. Always use coolant with the same LLC concentration.

Table 6-3 Recommended LLC concentration

Item	Type	External	Lowest ambient temperature			
			-10 °C [14 °F] or above	-20 °C [-4 °F] or above	-30 °C [-22 °F] or above	-45 °C [-40 °F] or above
LLC concentration (%)	GLASSY	Green	30	40	50	60
	PG GLASSY	Red	40	55	70	-

Note: (a) If the outside air temperature is -30 °C or less, use "GLASSY".

(b) The concentration above is based on Mitsubishi Heavy Industries, Ltd. genuine LLC "GLASSY long life coolant (Ethylene glycol type)" or "PG GLASSY long life coolant (Non-amine type)".

For determining the accurate LLC concentration, refer to the instructions for the LLC used.

## Importance of LLC

Today's trend is toward smaller and lighter engines offering greater output, lower fuel consumption and lower exhaust emission levels.

Conditions to which engine coolant is subjected, therefore, are becoming severer due to longer operating hours, higher coolant temperature and higher coolant circulating speed.

Many different materials such as steel, aluminum, copper, solder and rubber are used in the cooling system, and they are also subjected to the severe conditions described above. Those materials have different ionization characteristics, and this difference accelerates corrosion through the medium of engine coolant. To prevent such a problem, the use of LLC that contained the additive to prevent rust is very important.

## Characteristics of LLC additive and important notes

LLC contains several chemicals in such proportions as to produce chemical reactions that suppress corrosion (ionization) of engine parts in contact with the coolant. LLC loses its effectiveness by hours of use as well as lapse of time.

Moreover, if the chemicals in LLC are not maintained, certain chemicals in the LLC become rapidly used up and result in dissolution of metals instead of protecting metals from corrosion. Consequently, other corrosion preventing chemicals react with dissolving metals and accelerate corrosion. This condition generates more severe corrosion than when plain soft water is used. This is a typical problem caused by the use of inappropriate LLC.

## Examples of abnormalities caused by LLC (amine type)

### Pitting of iron parts

Amines are generally effective in suppressing the rusting of ferrous metals, but they are said to cause problems for copper parts.

Dissolved copper (copper corrosion) in the cooling system deposits on iron parts and the copper deposits cause corrosion and then pitting on iron parts that have a high ionization characteristics due to galvanic or local-cell action.

### Corrosion of aluminum parts

Silicate is highly effective in protecting aluminum against rusting. However, it is unstable in a solution in which the pH is 9 or lower, and can turn to gel and precipitate in the solution. For this reason, the pH is usually specified to be about 10 to ensure a high alkaline level.

This means, after silicate is used up, the high alkalinity causes chemical attacks on aluminum. To prevent this problem, proper maintenance of the coolant is required. For case example, rapid wear of mechanical seals in the water pump due to secondary effects of silicate gel formed. Corrosion of aluminum parts after silicate is consumed.

### Pitting and clogging of the radiator

When LLC deteriorates or when its concentration in the coolant is too low, the anti-corrosion performance of LLC lowers and results in the corrosion of metals. Brass and solder tend to corrode faster than other metals, and corrosion of these metals is said to cause water leakage and clogs. Example: Holes and clogs in radiator

# **Chapter 7 MAINTENANCE SCHEDULE**

---

## **How to use the maintenance schedule**

Periodic inspection not only extends the service life of the engine but also serves to ensure safe operation. Be sure to conduct inspections and maintenance according to the maintenance schedule.

The maintenance schedule shows the standard service intervals. If you notice any abnormalities such as abnormal noise, black exhaust smoke, white exhaust smoke, extremely high temperature of exhaust gas, abnormal vibration, and fuel, oil or exhaust gas leakage, make sure to conduct the inspection and maintenance work, regardless of recommended service intervals in the "Maintenance schedule."

Note: Appropriate service intervals vary depending on the usage and operating conditions as well as consumption of fuel, oil and coolant. Check the operating record of the engine to determine the most appropriate service intervals. (Feel free to consult a dealer of Mitsubishi Heavy Industries, Ltd. regarding service intervals.)

Service the items at multiples of the original requirement. For example, at 1000 service hours, also service those items listed under every 250 service hours and every 50 service hours.

Items marked with \* in the maintenance schedule require special tools or large equipment. For the servicing of those items, contact a dealer of Mitsubishi Heavy Industries, Ltd.

# Maintenance schedule

Table 7-1 Maintenance schedule

Interval and Service item		Page
Every 50 service hours	Fuel tank - Drain water (If water sedimenter is installed, drain water every 500 service hours or 1 year.)	8-2
	Air cleaner - Check	8-14
First 50 service hours for a new or overhauled engine	Solenoid fuel pump filter - Inspect and clean	8-2
	Engine oil and Oil filter - Replace	8-7
	Bolts and nuts on the engine - Retighten	*
Every 100 service hours	Solenoid fuel pump filter - Inspect and clean	8-2
Every 250 service hours	Engine oil and Oil filter - Replace	8-7
	Belt and belt tension - Inspect and Adjust	8-1
	Radiator fins - Check and Clean	8-13
Every 400 service hours	Fuel filter (cartridge type) - Replace	8-5
Every 500 service hours	Fuel filter element (switching cock type) - Replace	8-6
	Solenoid fuel pump filter - Replace	8-6
	Valve clearance - Inspect	*
	Cleaning the fuel tank (Every 500 service hours or Every 1 years)	*
	Checking glow plug	*
Every 1000 service hours	Starter - Inspect	8-17
	Alternator - Inspect	8-17
	Bolts and nuts on the engine - Retighten	*
Every 1500 service hours	Nozzle tip - Clean	*
Every 3000 service hours	Fuel injection nozzle - Check and maintenance	*
Every 2 years	Coolant - Change	8-10
As required	Air cleaner element - Clean, Check and Replace	8-15
	Fuel system - Bleed air	8-3
	Water sedimenter - Drain water	8-5
	Specific gravity of battery electrolyte - Check	8-16

# Chapter 8 PERIODIC INSPECTION AND MAINTENANCE PROCEDURES

## Basic engine

### Belt and belt tension - Inspect and Adjust

#### CAUTION

If defects such as cuts or surface separations are found during inspection, replace the belt.

Keep oil and grease away from the belt. They may cause the belt to slip and shorten the service life.

Excessive belt tension can cause rapid wear of the alternator bearing and shorten the service life of the belt.

Adjust the belt tension accurately by following the procedures below.

#### Belt - Inspect

1. Inspect the belt visually for separation or damage. If any abnormality is found, replace the belt with a new one.
2. Inspect belt tension (deflection).  
Push the belt downward at the midway between pulleys. If the deflection is 12 mm [0.47 in.], the tension is correct.  
Belt pushing force: Approx. 98 N {10 kgf} [22 lbf]  
If the deflection of belt is not within the standard, adjust the belt tension.

#### Belt tension (Alternator side) - Adjust

1. Remove the belt cover.
2. Loosen all retaining bolts of the alternator and adjusting plate.
3. Move the alternator to adjust the belt tension.
4. After adjusting the belt tension, tighten all retaining bolts of the alternator and adjusting plate.
5. Install the belt cover.

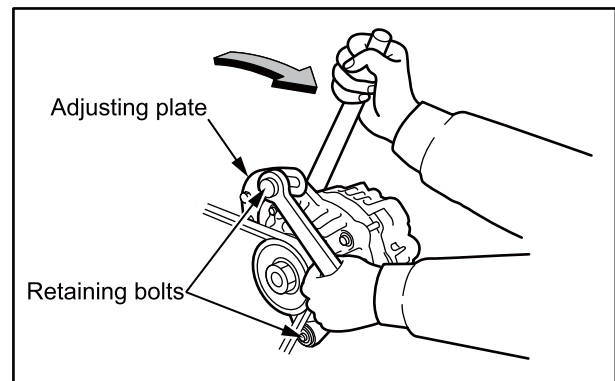

Fig. 8-1 Belt and belt tension - Inspect and Adjust

## Fuel system

### Fuel tank - Drain water

**WARNING**

When working around fuel, make sure there are no open flames, heaters or other fire hazards. Wipe off any spilled fuel completely. Spilled fuel can ignite and cause a fire.

**CAUTION**

Do not remove the strainer when filling the fuel. For fuel to be used, refer to "FUEL" (4-1).

Bleeding water procedure described below is a commonly used procedure. Some application may be equipped with different fuel tank.

If fuel gets mixed with particles of foreign materials such as dust, dirt, or water, it can cause not only decrease of output but also malfunctions of the fuel system. To avoid such a problem, drain fuel tank as described below.

1. Place a fuel tray (capacity of 2 L [0.5 U.S. gal.] or more) under the drain cock of fuel tank.
2. Open the drain cock of fuel tank and drain fuel at least 1 to 2 L [0.3 to 0.5 U.S. gal.].
3. Make sure that water and particles of foreign materials discharged with fuel. Close the drain cock.

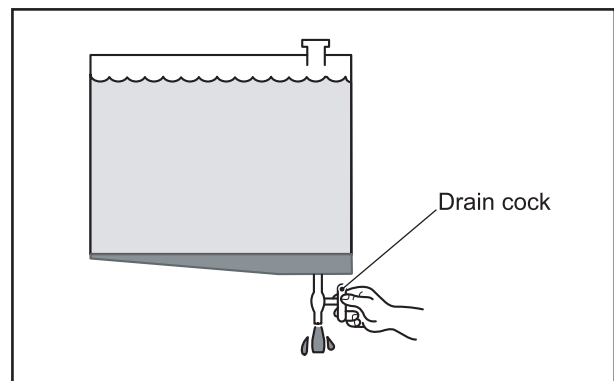

Fig. 8-2 Fuel tank - Drain water

### Solenoid fuel pump filter - Inspect and clean

**WARNING**

When handling fuel, make sure there are no open flames or other fire hazards near the engine. Wipe off any spilled fuel completely. Spilled fuel can ignite and cause a fire.

1. Clean around the solenoid fuel pump.
2. Check the starter key is at the "OFF" position.
3. Place a fuel tray under the solenoid fuel pump.
4. Close the valve to stop fuel flow.
5. Remove the lower solenoid fuel pump cover.
6. Soak the gaskets, filter, magnet and cover in fuel to clean.
7. Inspect if there is any damaged part, and if so, change it for a new one.
8. Put all the parts back together in a reverse way.
9. Open the main valve of the fuel tank.
10. Turn the starter switch to the "ON" position.
11. Make sure that solenoid fuel pump clicks and fuel starts to flow.
12. Check the solenoid fuel pump for fuel leakage. If leakage is found, reassemble again.
13. Bleed air from the fuel system.  
Refer to "Fuel system - Bleed air" (8-3).

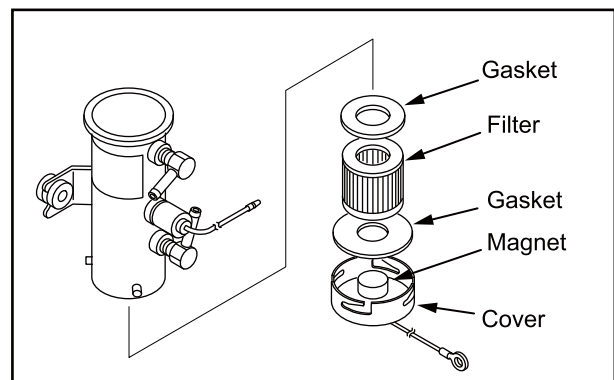

Fig. 8-3 Solenoid fuel pump filter - Inspect and clean

## Fuel system - Bleed air

### WARNING

When handling fuel, make sure there are no open flames or other fire hazards near the engine.

Wipe off any spilled fuel completely. Spilled fuel can ignite and cause a fire.

When cleaning or replacing the parts of fuel system, perform air bleeding from each parts.

Note: Air in the fuel injection pipe and nozzle is discharged automatically by clanking of engine.

### Fuel filter element (switching cock type) - Bleed air

1. Turn the fuel filter cock to "AIR" position.
2. Feed fuel using the solenoid fuel pump.
3. Return the cock to "ON" position when the fuel flow from overflow pipe becomes free of bubbles.
4. Stop feeding fuel.

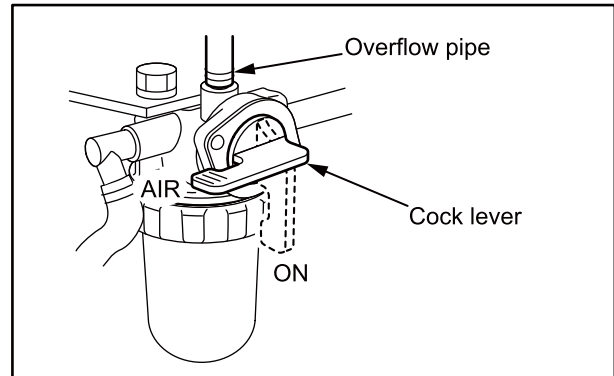

Fig. 8-4 Fuel filter element (switching cock type) - Bleed air

### Fuel filters (cartridge type) - Bleed air

1. Loosen air vent plug 1 of fuel filter.
2. Feed fuel using the solenoid fuel pump.
3. When the fuel from the air vent plug 1 becomes free of bubbles, stop priming and tighten the air vent plug 1 to the specified torque.
4. Loosen air vent plug 2 of fuel filter.
5. When the fuel from the air vent plug 2 becomes free of bubbles, stop priming and tighten an air vent plug 2 to the specified torque.
6. Stop feeding fuel.

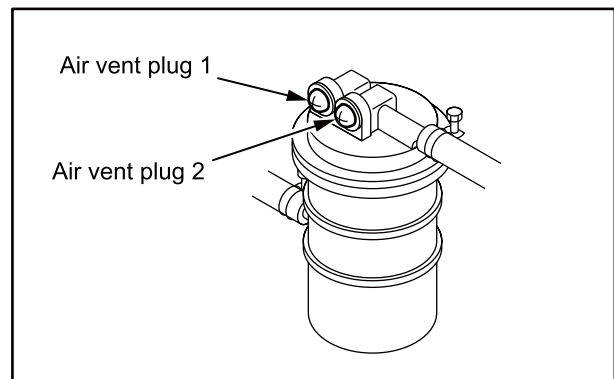

Fig. 8-5 Fuel filters (cartridge type) - Bleed air

### Water sedimenter - Bleed air

1. Loosen the fuel inlet port air vent plug of water sedimenter.
2. Feed fuel using the solenoid fuel pump.
3. When the fuel from the fuel inlet air vent plug becomes free of bubbles, stop priming and tighten the plug to the specified torque.
4. Loosen the fuel outlet air vent plug.
5. When the fuel from the fuel outlet air vent plug becomes free of air bubbles, stop priming and tighten the plug to the specified torque.
6. Stop feeding fuel.

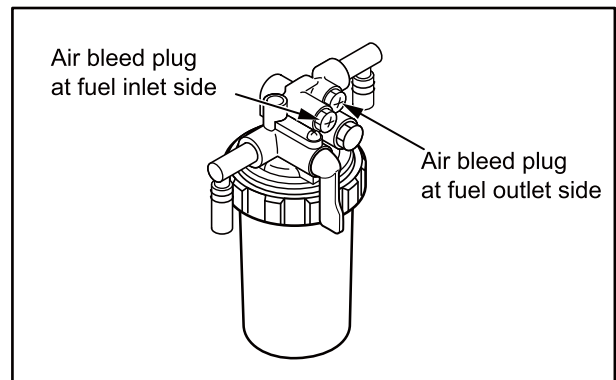

Fig. 8-6 Water sedimenter - Bleed air

## Water sedimenter - Drain water

### WARNING

When handling fuel, make sure there are no open flames or other fire hazards near the engine.

Wipe off any spilled fuel completely. Spilled fuel can ignite and cause a fire.

1. Clean around the water sedimenter.
2. Place a fuel tray under the water sedimenter.
3. Turn the cock to "C" (close) position, stop the flow of fuel.
4. Remove ring nut and cup.
5. Drain water in the cup and soak the element in fuel to clean.
6. Install filter element and cup with careful attention to O-ring and then fix with ring nut.
7. Bleed air of water sedimenter.  
(Refer to ["Water sedimenter - Bleed air" \(8-4\)](#))
8. Turn the cock to "O" (open) position, start the engine and let it idle for several minutes.
9. Check the water sedimenter for fuel leakage. If leakage is found, loosen ring nut and check O-ring for damage.

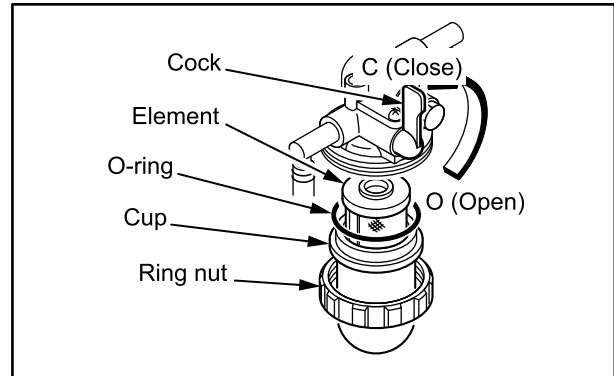

Fig. 8-7 Water sedimenter - Drain water

## Fuel filter (cartridge type) - Replace

### WARNING

When handling fuel, make sure there are no open flames or other fire hazards near the engine.

Wipe off any spilled fuel completely. Spilled fuel can ignite and cause a fire.

1. Clean the area around the fuel filters.
2. Place a fuel tray under the fuel filter.
3. Put a stopper on fuel pipe and stop fuel flow.
4. Change the fuel filter for a new one.
5. Bleed air from the fuel filter.  
Refer to ["Fuel system - Bleed air" \(8-3\)](#).
6. Start the engine and let it idle for several minutes.
7. Check the fuel filter for fuel leakage. If fuel leakage is found, retighten the fixing clamp of the fuel pipe.

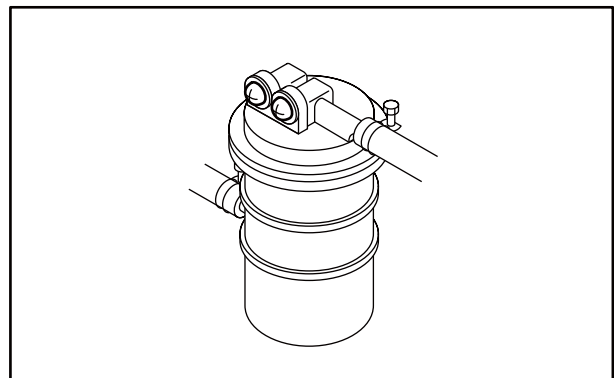

Fig. 8-8 Fuel filter (cartridge type) - Replace

## Fuel filter element (switching cock type) - Replace

**WARNING**

When handling fuel, make sure there are no open flames or other fire hazards near the engine. Wipe off any spilled fuel completely. Spilled fuel can ignite and cause a fire.

1. Clean the area around the fuel filters.
2. Place a fuel tray under the fuel filter.
3. Turn the cock to "C" (close) position, stop fuel flow.
4. Remove ring nut and cup, change the filter element for a new one and then fix the ring nut.
5. Bleed air from the fuel filter.  
Refer to ["Fuel system - Bleed air" \(8-3\)](#).
6. Turn the cock to "ON" position, start the engine and let it idle for several minutes.
7. Check the fuel filter for fuel leakage. If leakage is found, loosen ring nut and check O-ring for damage.

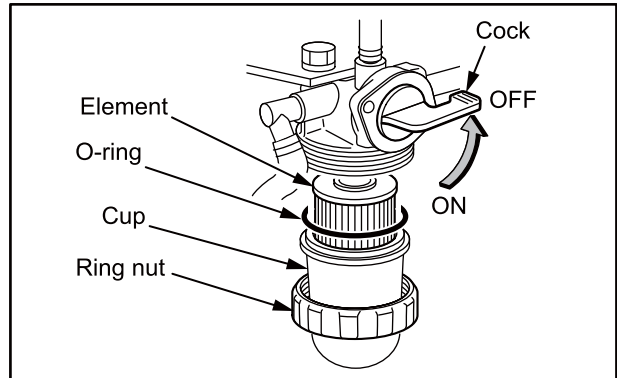

Fig. 8-9 Fuel filter element (switching cock type) - Replace

## Solenoid fuel pump filter - Replace

**WARNING**

When handling fuel, make sure there are no open flames or other fire hazards near the engine. Wipe off any spilled fuel completely. Spilled fuel can ignite and cause a fire.

1. Clean around the solenoid fuel pump.
2. Check the starter key is at the "OFF" position.
3. Place a fuel tray under the solenoid fuel pump.
4. Close the valve to stop fuel flow.
5. Remove the lower solenoid fuel pump cover.
6. Change the element for a new one.
7. Inspect if there is any damaged part, and if so, change it for a new one.
8. Put all the parts back together in a reverse way.
9. Open the main valve of the fuel tank.
10. Turn the starter switch to the "ON" position.
11. Make sure that solenoid fuel pump clicks and fuel starts to flow.
12. Check the solenoid fuel pump for fuel leakage. If leakage is found, reassemble again.
13. Bleed air from the fuel system.  
Refer to ["Fuel system - Bleed air" \(8-3\)](#).

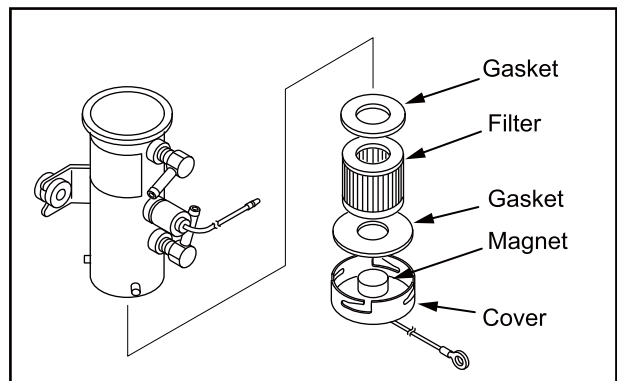

Fig. 8-10 Solenoid fuel pump filter - Replace

## Lubricating system

### Engine oil and Oil filter - Replace

**CAUTION**

When draining oil or changing the oil filter, wear gloves. Hot engine oil and parts may cause burns.

**CAUTION**

Do not dump waste oil. It is forbidden by law. For disposal of waste oil, consult a dealer of Mitsubishi Heavy Industries, Ltd.

Change engine oil and the oil filter at the same time.

Also checking and analyzing the oil properties is recommended when changing the engine oil.

Do not reuse the oil filter element, as it is a paper type. When replacing filters, always replace gasket with new ones.

### Engine oil - Drain

After the engine has stopped, drain engine oil from the engine oil drain port.

Note: Draining by suction should be avoided.

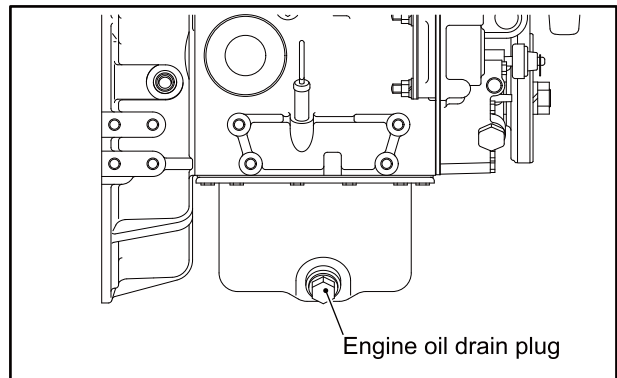

Fig. 8-11 Engine oil drain plug

## Engine oil - Refill

1. Make sure that the oil drain plug is tightened.
2. Remove the oil filler cap.
3. Fill the engine oil pan with specified engine oil to the specified level.

Note: For engine oil, refer to "ENGINE OIL" (5-1). For engine oil capacity, refer to "MAIN SPECIFICATIONS" (12-1).

4. Check the oil level in the oil pan as follows:
5. Pull out the oil level gauge, and wipe it with a waste cloth.
6. Insert the oil level gauge fully into the oil level gauge guide, then pull out the gauge again.
7. The proper oil level is between the high and low marks on the oil level gauge. If the oil level is low, add engine oil of the specified type.
8. Check the oil pan and other area for oil leakage. Repair any oil leakage found.
9. Run the engine with starter for approx. 10 seconds while pulling the stop lever and feed engine oil to all parts of engine. Stop the operation for 1 minute, then, repeat the operation two or three times. Circulate engine oil to all parts of the engine.

Note: Prepare for the Cooling system.

10. Check the oil level with the oil level gauge again, and add oil to the specified level.

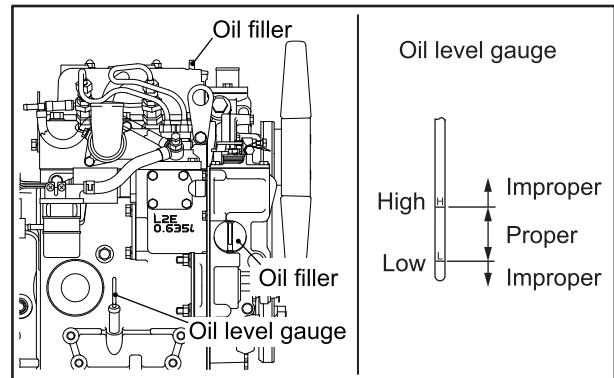

Fig. 8-12 Engine oil - Refill

## Oil filter - Change

### WARNING

Do not use a dented filter cartridge.  
Filter damage or fuel leakage may occur while engine is running and it can cause fire hazard.

### CAUTION

To avoid damage to the filter, do not use a filter wrench when installing. Tighten the filter by hand.

1. Clean around the oil filters.
2. Place a drip pan under the oil filter.
3. Using a filter wrench, remove the oil filter.

Note: Check the element of the oil filter that has been removed. If metal particles are found, consult a dealer of Mitsubishi Heavy Industries, Ltd.

4. Thoroughly wipe off oil on the mounting surface of oil filter with a waste cloth.
5. Check the new oil filter for proper seating of gasket.
6. Apply clean engine oil to gasket.
7. Install the oil filter. When the filter gasket contacts the mounting surface of filter, tighten the filter with specified torque.

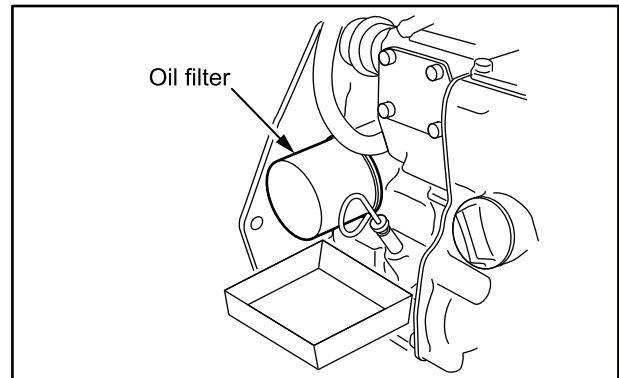

Fig. 8-13 Oil filter - Change

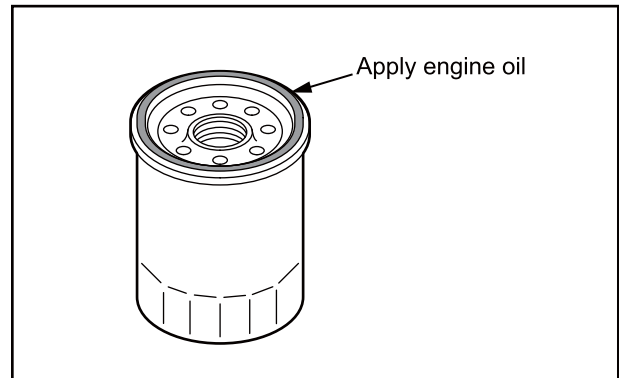

Fig. 8-14 Oil filter

## Cooling system

### Coolant - Change

**WARNING**

Remove the radiator filler cap only after the engine has cooled to room temperature. Place a waste cloth over the cap, and loosen the cap about a half-turn or stand the lever to the upright position to release internal pressure. Never open the radiator filler cap while the engine is hot, otherwise the steam or hot coolant spurts out and you may be scalded with it.

Coolant (containing LLC) drained from the engine is toxic. Never dispose of coolant into regular sewage. For disposal of used coolant, consult a dealer of Mitsubishi Heavy Industries, Ltd. or a industrial waste disposer.

**CAUTION**

The service life of LLC is 2 years. Be sure to change coolant at least once every 2 years.

### Coolant - Drain

1. When draining coolant immediately after engine operation, idle the engine in low gear for 5 to 6 minutes until the coolant temperature drops to 70 to 80 °C [158 to 176 °F].
2. Open the radiator filler cap.
3. Place coolant receiving can under the drain cocks and plugs, and open the coolant drain cocks and plugs to drain the coolant.

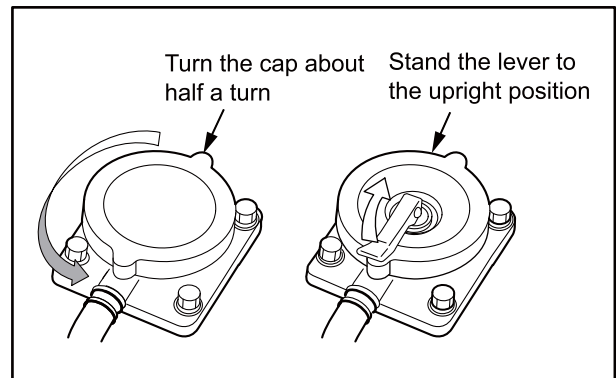

Fig. 8-15 Radiator filler cap

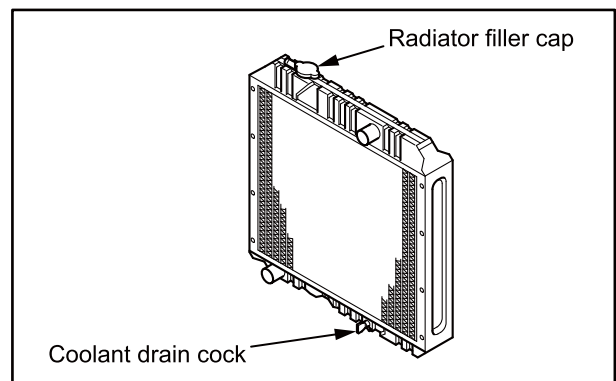

Fig. 8-16 Coolant drain cock (radiator)

## Cooling system - Clean

### CAUTION

Clean the cooling system when operating the engine first time, or restarting the engine after storage with coolant drained.

1. Close coolant drain cocks and plugs.
2. Pour in a cleaning solution (a solution that is non-corrosive to rubber and metals) in the cooling system, and operate the engine at 800 to 900  $\text{min}^{-1}$  for about 15 minutes, then drain the cleaning solution.
3. Close coolant drain cocks and plugs.
4. Pour in fresh water, and operate the engine at 800 to 900  $\text{min}^{-1}$  for about 10 minutes.

Repeat rinsing until the draining water becomes clear and clean.

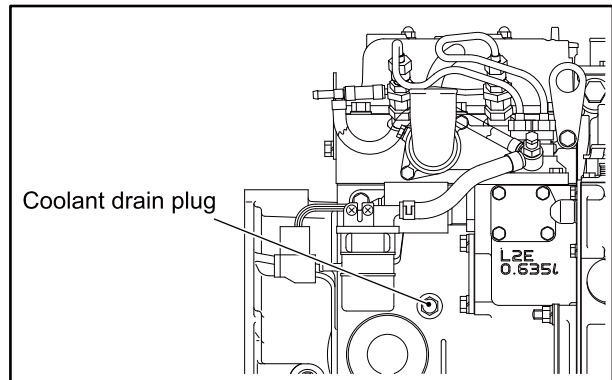

Fig. 8-17 Coolant drain plug (engine)

### Coolant - Refill

1. Tighten the coolant drain cocks and plugs.
2. Remove the radiator filler cap, and pour in undiluted LLC.

Note: Determine the amounts of LLC and water to be added by using the LLC concentration chart.

For the coolant, refer to "COOLANT" (6-1). For the coolant capacity, refer to "MAIN SPECIFICATIONS" (12-1).

3. Pour in water (soft water with minimal impurities, such as tap water) slowly to "FULL" level line.
4. Check the radiator and other parts for coolant leakage. If any coolant leakage is found, repair it.
5. When coolant reaches "FULL" level line, close the radiator filler cap securely.
6. Run the engine with starter for approx. 10 seconds while pulling the stop lever.  
Stop the operation for 1 minute, then, repeat the operation two or three times to bleed the cooling system.
7. Check the coolant level in the radiator.  
If the engine is equipped with a reserve tank, fill the reserve tank with coolant to "FULL" level line as well.

**CAUTION**

Always use the coolant with the same LLC concentration.

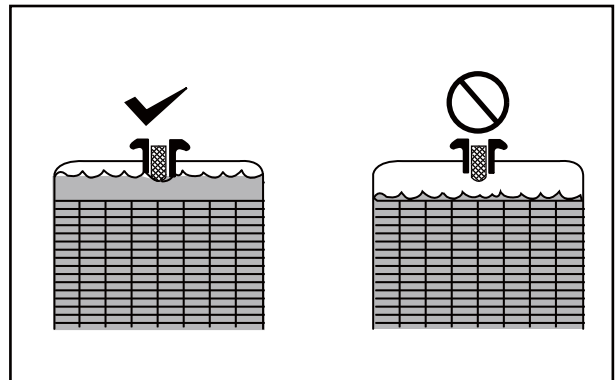

Fig. 8-18 Radiator coolant level

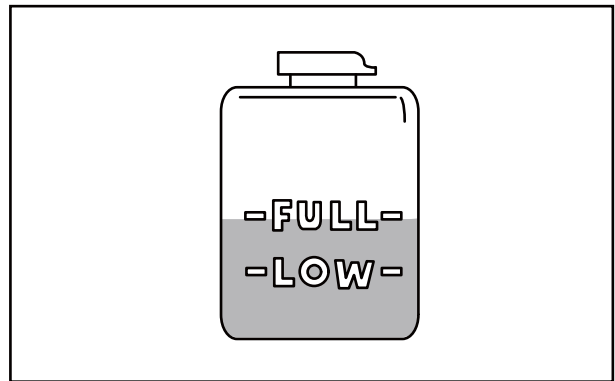

Fig. 8-19 Reserve tank

## Radiator fins - Check and Clean

**CAUTION**

When handling compressed air, wear safety goggles, a hardhat, gloves and other necessary protective gear. Works without wearing proper protective gear could result in serious injuries.

Check the radiator fins for holes and cracks.

To clean the radiator fins, blow compressed air from the opposite direction of the normal air flow.

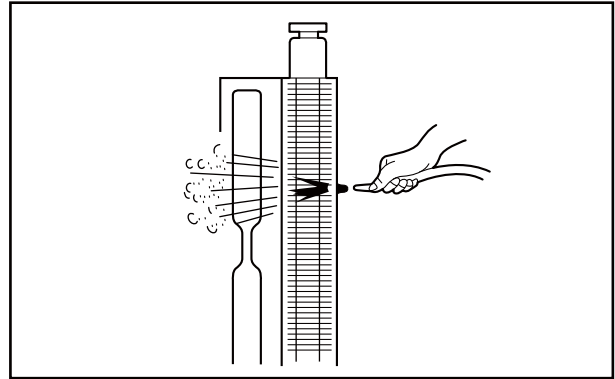

Fig. 8-20 Radiator fins - Clean

## Inlet and exhaust systems

### Air cleaner - Check

**CAUTION**

Checking procedure described below is a commonly used procedure. Some application may be equipped with different air cleaner.

1. Check the air cleaner indicator for the element clog.
2. If the element is clogged, the red signal mark is visible.
3. Immediately clean or replace the air cleaner element when the signal turns red.

Note: For cleaning of the air cleaner element, refer to ["Air cleaner element - Clean, Check and Replace" \(8-15\)](#).

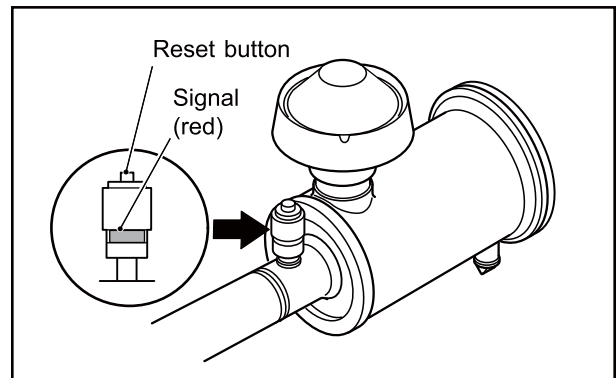

Fig. 8-21 Air cleaner - Check

## Air cleaner element - Clean, Check and Replace

### CAUTION

When handling compressed air, wear safety goggles, a dust mask, a hardhat, gloves and other necessary protective gear. Works without wearing proper protective gear could result in serious injuries.

Never service the air cleaner while the engine is running. Servicing the air cleaner while the engine is running can cause particles of foreign material to enter the engine and result in rapid wear of parts, leading to a shorter service life of the engine. Never knock or hit the element.

### CAUTION

Cleaning, inspecting and replacing procedure described below is a commonly used procedure. Some application may be equipped with different air cleaner.

1. Remove the air cleaner cap and wing bolt.
2. Remove the air cleaner element from the body.
3. Blow compressed air (0.69 MPa {7 kgf/cm<sup>2</sup>} [100 psi] or lower) onto the inside surface of the element to remove foreign materials.
4. To remove dust stuck on the air cleaner element, blow dry compressed air onto the outside surface from a distance.  
Blow compressed air on the inside surface toward the outside along the pleats. Then, blow compressed air on the outside and inside surface again.
5. After cleaning, hold the air cleaner element near a light bulb to illuminate the inside, to check for defects such as cuts, pinholes or local wear.
6. If any defect is found, replace the air cleaner element with a new one.
7. Reassemble the air cleaner element as it is.

### CAUTION

If defects such as cuts, pinholes or local wear are found in the element, or if the air cleaner indicator shows a red sign soon after the cleaned element is installed, change it for new one.

After cleaning or replacing the air cleaner element, press the reset button to reset the indicator.

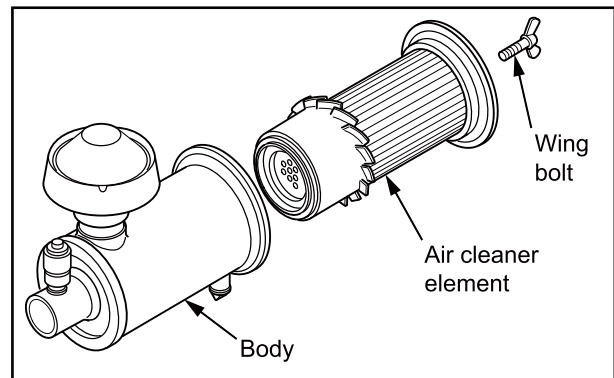

Fig. 8-22 Air cleaner element - Remove

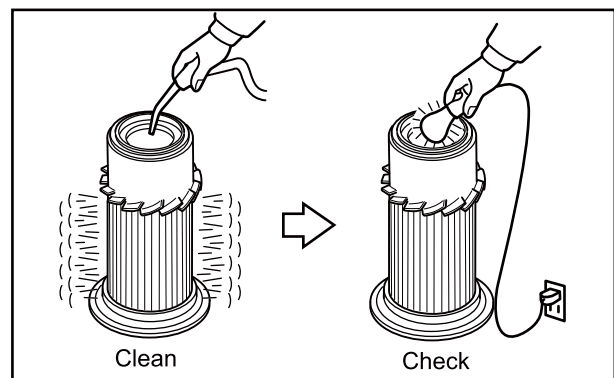

Fig. 8-23 Air cleaner element - Clean and Check

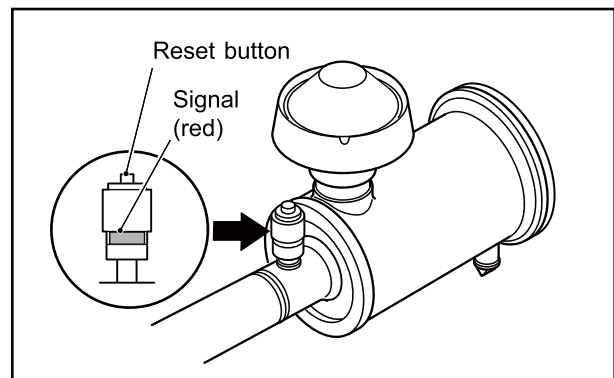

Fig. 8-24 Air cleaner - Check

# Electrical system

## Battery - Inspect

**CAUTION**

If battery electrolyte is spilled on your skin, flush immediately with plenty of water. If battery electrolyte enters the eyes, flush them immediately with lots of fresh water and seek medical attention at once.

Do not use open flames or other fire hazards near the battery. When handling the battery, be careful of sparks generated by accidental shorting.

### Battery electrolyte level - Inspect

Battery electrolyte evaporates during use and the electrolyte level gradually decreases. The proper electrolyte surface level is between the "LOWER LEVEL" and "UPPER LEVEL" lines.

For the battery without level lines, the proper electrolyte surface level is about 10 to 15 mm [0.394 to 0.591 in.] above the top of the plates.

If the electrolyte level is low, remove the caps and add distilled water to the proper level.

Note: When adding distilled water, pour in carefully.

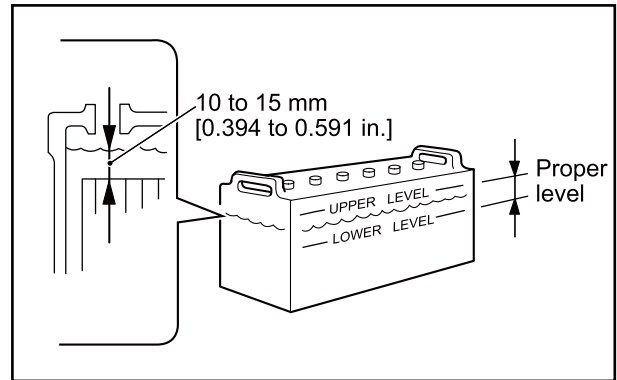

Fig. 8-25 Battery electrolyte level - Inspect

### Specific gravity of battery electrolyte - Check

If the specific gravity measured at 20 °C [68 °F] is lower than 1.22, then charge the electrolyte.

Table 8-1 Specific gravity of electrolyte

Specific gravity at 20 °C [68 °F]	Condition	Remedy
From 1.26 to 1.28	Fully charged	-
From 1.22 to 1.26	Charged	Charge
Less than 1.22	Discharged	Charge

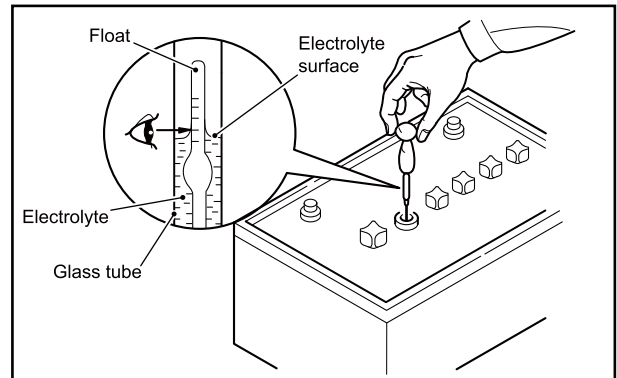

Fig. 8-26 Specific gravity of battery electrolyte - Check

## Starter - Inspect

Visually check the starter for damage.

If the starter is dusty, blow dirt using compressed air.

Note: If the starter is defective, consult a dealer of Mitsubishi Heavy Industries, Ltd.

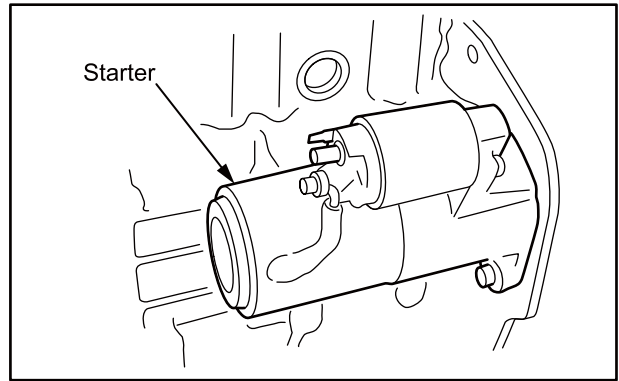

Fig. 8-27 Starter - Inspect

## Alternator - Inspect

Visually check the alternator for damage.

If the alternator is dusty, blow foreign material using compressed air.

Remove the belt and check that the movement is smooth when rotating the pulley by hand.

Note: If the alternator is defective, consult a dealer of Mitsubishi Heavy Industries, Ltd.

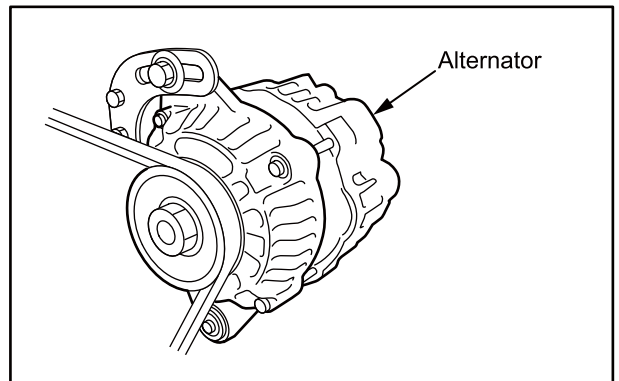

Fig. 8-28 Alternator - Inspect



# Chapter 9 LONG-TERM STORAGE

## Long-term storage

The following describes how to store the engine in a non-operable condition for 3 months or more and in an operable condition for 3 months or more.

If the engine has been left unattended for 3 months or more, the internal engine parts can rust, and that may cause damage to the engine.

When storing the engine for an extended period of time, be sure to follow the directions below.

## Storing the engine in a non-operable condition for 3 months or more

### Preparation for storage

1. Drain the engine oil in-use, pour new oil.
2. Prepare a fuel mixture containing 50 % rust-preventive oil (NP-9), and fill the fuel tank with it.
3. Operate under non-load minimum engine speed for 5 to 10 minutes.
4. Immediately before stopping the engine, spray volatile corrosion inhibitor (VCI) through the inlet port to prevent rust on the air intake system.
5. With the engine stopped, drain the fuel mixture from the fuel tank.
6. Apply rust-preventive oil (NP-3) liberally on the exposed sections of the machining.
7. Seal the air inlet, exhaust outlet, breather and other openings with an adhesive cloth tape.
8. Cover the entire engine.

Note: (a) Store the engine in a well-ventilated indoor area.

(b) It is not necessary to drain coolant since it contains LLC. (Add LLC to increase the concentration to between 30 to 60 %.)

(c) Post a sign at an easily noticeable place to warn that the rust-preventive oil in the engine must be replaced with engine oil, and the fuel tank must be filled with fuel before operating the engine for the first time after storage.

(d) New engine oil can substitute for rust-preventive oil (NP-10-2) of lubrication system.

### Recommended rust-preventive oil and corrosion inhibitor

Table 9-1 Recommended rust-preventive oil and corrosion inhibitor

JIS No.		Recommended product	Application
K 2246	NP-3	Nippon Oil Corporation Anti Rust P-1600	Prevention of rust on exposed machine sur- faces
	NP-9	Nippon Oil Corporation Anti Rust P-2400	Prevention of rust in fuel system
	NP-10-2	Nippon Oil Corporation Anti Rust P-230	Prevention of rust in lubricating system
Z 1519	-	Ryokou Kagaku VCI Diana ND volatile corrosion inhibitor	Prevention of rust in air intake system

### Maintenance during storage

Charge the battery once a month. First, check the battery electrolyte for proper level and then charge the battery.

## Using the engine after storage

1. Remove the cover from the engine.
2. Connect a fully charged battery.
3. Remove the covers from the starters and alternator.
4. Adjust the tension of belt.

Note: Inspect and adjust V-belt tension. Refer to ["Belt and belt tension - Inspect and Adjust" \(8-1\)](#).

5. Remove sealing tapes from the openings of the engine.
6. Connect pipes.

Note: For engine oil, refer to ["ENGINE OIL" \(5-1\)](#).

7. Fill the fuel tank with fuel, and bleed the fuel system.

Note: For bleeding fuel system, refer to ["Fuel system - Bleed air" \(8-3\)](#).

8. Inspect the entire engine.
9. Remove the rocker covers, and lubricate the valve mechanisms.
10. Run the engine with starter for approx. 10 seconds while pulling the stop lever. Stop the operation for approx. 1 minute, then, repeat the operation two or three times.
11. Make sure the engine oil pressure rises.
12. Conduct a warm up operation for a sufficient duration.

Note: For starting the engine, refer to ["Starting" \(3-4\)](#).

13. Apply load and increase the engine speed to the rated speed.

## Storing the engine in an operable condition for 3 months or more

When the engine is not operated during storage of 3 months or more, internal engine parts can rust and lose oil film. As a result, the engine can seize when it is started after storage. To prevent such a risk, the engine must be operated periodically during storage.

### Operating the engine for maintenance

Operate the engine for maintenance at least once a month as described below.

1. Run the engine with starter for approx. 10 seconds while pulling the stop lever. Stop the operation for approx. 1 minute, then, repeat the operation two or three times.
2. Make sure the engine oil pressure rises.
3. Operate the engine about 5 to 10 minutes under no load as the maintenance operation.

Note: For starting the engine, refer to ["Starting" \(3-4\)](#).

# Chapter 10 TRANSPORTATION

## Lifting the engine

**WARNING**

To lift the engine, use wire ropes, shackles and slings capable of supporting the weight of the engine.

Attach the wire rope to the hangers provided on the engine using a correct sling.

Keep the engine balanced during lifting by considering the engine's center of gravity.

Keep the angle formed by slings attached to hangers within 60°. If the angle exceeds this limit, excessive load could be imposed on the hangers and this could damage the hangers and result in a serious accident.

Attach wire ropes to the hangers after removing the pipe cover and the insulator near the hangers. To prevent wire ropes from contacting the engine, use a cloth or other soft padding.

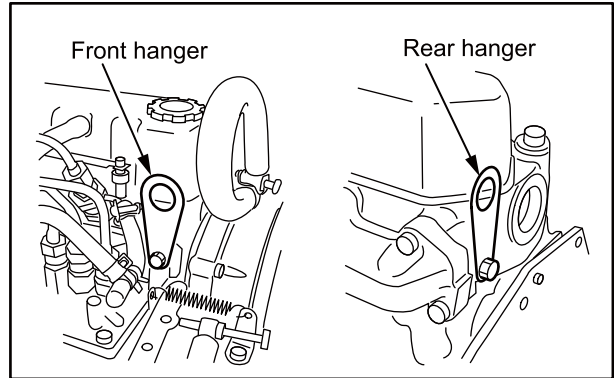

Fig. 10-1 Hangers

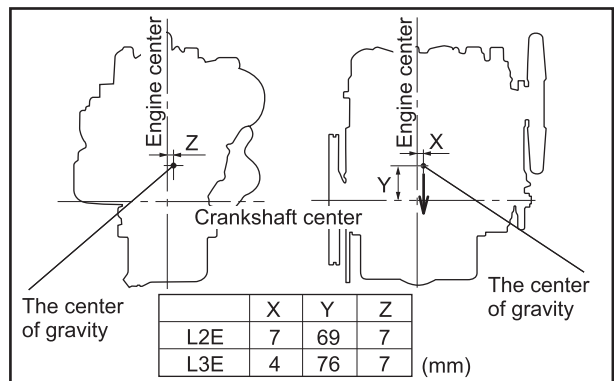

Fig. 10-2 Engine's center of gravity (standard specification)



# Chapter 11 TROUBLESHOOTING

---

## General precautions

### Contact a dealer of Mitsubishi Heavy Industries, Ltd. for repair service

Repairing a malfunctioning engine may require special equipment or involve potentially dangerous work, except for relatively simple procedures such as the change and addition of fuel, engine oil and coolant. In the event of the engine failure, contact a dealer of Mitsubishi Heavy Industries, Ltd.

### Considerations before work

Before troubleshooting, consider possible causes of the problem and try to find out if the same problem has occurred in the past.

Check the parts that may be causing the problem in the most efficient order.

When disassembling a component, pay close attention to the disassembly sequence so that you can reassemble the component in reverse order of disassembly.

### Cautions against contamination

Dust and foreign materials are the most common cause of rapid wear of parts.

When disassembling a component, take measures to prevent dust and foreign materials from entering the component being disassembled.

### Cautions regarding parts handling

Handle parts carefully.

When replacing parts, use only genuine parts by referring to the parts catalogue.

### Work safety

Be sure to use wrenches of the correct size. Using a wrench of the wrong size not only damages nuts but can also cause the personal injury.

Use correct tools and perform work with utmost caution.

Be sure to accurately estimate the weight of the part being dismantled. If the removed part is much heavier than you have estimated, it may fall down during lifting and can result in the damage to the parts or personal injury.

## Troubleshooting

### The starter does not crank or cranks slowly, resulting in start failure

Table 11-1 The starter does not crank or cranks slowly, resulting in start failure

Cause		Remedies
Electrical system	Faulty wire connection	<ul style="list-style-type: none"> <li>♦Check the DC fuse.</li> <li>♦Check wiring connection between battery, starter and starter switch.</li> </ul>
	Insufficiently charged battery	<ul style="list-style-type: none"> <li>♦Check alternator. (Refer to P8-17)</li> <li>♦Check and adjust belt. (Refer to P8-1)</li> </ul>
	Faulty battery	<ul style="list-style-type: none"> <li>♦Check specific gravity of battery electrolyte. (Refer to P8-16)</li> <li>♦Charge battery.</li> <li>♦Change battery.</li> </ul>
	Faulty starter or starter relay	<ul style="list-style-type: none"> <li>♦Consult a dealer of Mitsubishi Heavy Industries, Ltd.</li> </ul>
Lubricating system	Oil viscosity too high	<ul style="list-style-type: none"> <li>♦Use appropriate engine oil. (Refer to P5-1)</li> </ul>
	Excessive oil	<ul style="list-style-type: none"> <li>♦Check amount of engine oil and lubrication system. (Refer to P3-2)</li> </ul>
Engine mechanical	Rapid wear of sliding parts, or locked	<ul style="list-style-type: none"> <li>♦Consult a dealer of Mitsubishi Heavy Industries, Ltd.</li> </ul>

### The starter cranks, but the engine does not start

Table 11-2 The starter cranks, but the engine does not start

Cause		Remedies
Fuel system	Run out of fuel, blocked pipe	<ul style="list-style-type: none"> <li>♦Inspect fuel tank, supply fuel, bleed air. (Refer to P8-2)</li> <li>♦Check fuel pipes, valves.</li> </ul>
	Improper fuel property	<ul style="list-style-type: none"> <li>♦Use appropriate fuel. (Refer to P4-1)</li> <li>♦Remove dust, water impurities. (Refer to P8-2)</li> </ul>
	Fuel leakage in fuel pipes and injection pipes.	<ul style="list-style-type: none"> <li>♦Check faults and retighten fuel pipes and injection pipes.</li> <li>♦Consult a dealer of Mitsubishi Heavy Industries, Ltd.</li> </ul>
	Clogged fuel filter	<ul style="list-style-type: none"> <li>♦Inspect and replace fuel filter. (Refer to P8-5) or (Refer to P8-6)</li> <li>♦Gauze filter - Clean</li> </ul>
	Faulty fuel feed pump	<ul style="list-style-type: none"> <li>♦Consult a dealer of Mitsubishi Heavy Industries, Ltd.</li> </ul>
	Faulty fuel injection pump	<ul style="list-style-type: none"> <li>♦Check the rack movement.</li> <li>♦Consult a dealer of Mitsubishi Heavy Industries, Ltd.</li> </ul>
	Faulty fuel injection nozzle	<ul style="list-style-type: none"> <li>♦Consult a dealer of Mitsubishi Heavy Industries, Ltd.</li> </ul>
Air intake system	Insufficient amount of air	<ul style="list-style-type: none"> <li>♦Clean, inspect and replace air cleaner element. (Refer to P8-14)</li> </ul>
Control system	Faulty governor	<ul style="list-style-type: none"> <li>♦Fuel control link - Check</li> <li>♦Consult a dealer of Mitsubishi Heavy Industries, Ltd.</li> </ul>
Basic engine	Low compression pressure	<ul style="list-style-type: none"> <li>♦Consult a dealer of Mitsubishi Heavy Industries, Ltd.</li> </ul>

## Output decrease

Table 11-3 Output decrease

Cause		Remedies
Fuel system	Improper fuel property	♦Use appropriate fuel. (Refer to P4-1)
	Clogged fuel filter	♦Inspect and replace fuel filter. (Refer to P8-5) or (Refer to P8-6) ♦Gauze filter - Clean
	Faulty fuel feed pump	♦Consult a dealer of Mitsubishi Heavy Industries, Ltd.
	Faulty fuel injection pump	♦Consult a dealer of Mitsubishi Heavy Industries, Ltd.
	Faulty fuel injection nozzle	♦Consult a dealer of Mitsubishi Heavy Industries, Ltd.
	Faulty fuel injection timing	♦Consult a dealer of Mitsubishi Heavy Industries, Ltd.
	Improper amount of injected fuel	♦Check fuel injection pump rack stroke. ♦Consult a dealer of Mitsubishi Heavy Industries, Ltd.
Cooling system	Overheat, overcooled	♦Check fan and radiator. ♦Check control system. ♦Consult a dealer of Mitsubishi Heavy Industries, Ltd.
Inlet and exhaust systems	Insufficient amount of air	♦Clean, inspect and replace air cleaner element. (Refer to P8-15) ♦Check intake air pressure and leakage of intake air. ♦Check intake air temperature and ventilation device. ♦Consult a dealer of Mitsubishi Heavy Industries, Ltd.
	Increase resistance of exhaust air.	♦Check exhaust pipes and silencer. ♦Consult a dealer of Mitsubishi Heavy Industries, Ltd.
Basic engine	Low compression pressure	♦Consult a dealer of Mitsubishi Heavy Industries, Ltd.
	Faulty valve timing	♦Consult a dealer of Mitsubishi Heavy Industries, Ltd.
	Rapid wear of sliding parts	♦Consult a dealer of Mitsubishi Heavy Industries, Ltd.
Control system	Faulty governor control	♦Consult a dealer of Mitsubishi Heavy Industries, Ltd.

## Exhaust smoke is white or blue

Table 11-4 Exhaust smoke is white or blue

Cause		Remedies
Fuel system	Improper fuel property	♦Check cetane index, and use appropriate fuel. ( <a href="#">Refer to P4-1</a> )
	Faulty fuel injection timing	♦Consult a dealer of Mitsubishi Heavy Industries, Ltd.
	Faulty fuel injection nozzle	♦Consult a dealer of Mitsubishi Heavy Industries, Ltd.
	Uneven fuel injection	♦Check ignition noise, exhaust smoke temperature. ♦Consult a dealer of Mitsubishi Heavy Industries, Ltd.
	Incorrect fuel injection timing	♦Consult a dealer of Mitsubishi Heavy Industries, Ltd.
Lubricating system	Combustion of engine oil	♦Check amount of engine oil and lubrication system. ( <a href="#">Refer to P3-2</a> ) ♦Consult a dealer of Mitsubishi Heavy Industries, Ltd.
Cooling system	Overcooled	♦Check radiator. ( <a href="#">Refer to P8-13</a> ) ♦Check control system. ♦Thermostat - Inspect ♦Consult a dealer of Mitsubishi Heavy Industries, Ltd.
Basic engine	Faulty valve timing	♦Consult a dealer of Mitsubishi Heavy Industries, Ltd.
	Low compression pressure	♦Consult a dealer of Mitsubishi Heavy Industries, Ltd.

## Exhaust smoke is black or charcoal

Table 11-5 Exhaust smoke is black or charcoal

Cause		Remedies
Fuel system	Improper fuel property	♦Use appropriate fuel. ( <a href="#">Refer to P4-1</a> )
	Faulty fuel feed pump	♦Consult a dealer of Mitsubishi Heavy Industries, Ltd.
	Faulty fuel injection pump	♦Consult a dealer of Mitsubishi Heavy Industries, Ltd.
	Faulty fuel injection nozzle	♦Consult a dealer of Mitsubishi Heavy Industries, Ltd.
	Faulty fuel injection timing	♦Consult a dealer of Mitsubishi Heavy Industries, Ltd.
	Uneven fuel injection	♦Check exhaust smoke temperature. ♦Consult a dealer of Mitsubishi Heavy Industries, Ltd.
Inlet and exhaust systems	Insufficient amount of air	♦Clean, inspect and replace air cleaner element. ( <a href="#">Refer to P8-15</a> ) ♦Check intake air pressure and leakage of intake air. ♦Check intake air temperature and ventilation device. ♦Consult a dealer of Mitsubishi Heavy Industries, Ltd.
	Increase resistance of exhaust air.	♦Check exhaust pipes and silencer. ♦Consult a dealer of Mitsubishi Heavy Industries, Ltd.
Basic engine	Low compression pressure	♦Consult a dealer of Mitsubishi Heavy Industries, Ltd.
	Faulty valve timing	♦Consult a dealer of Mitsubishi Heavy Industries, Ltd.
	Rapid wear of sliding parts	♦Consult a dealer of Mitsubishi Heavy Industries, Ltd.
Control system	Increase in load	♦Check control system. ♦Consult a dealer of Mitsubishi Heavy Industries, Ltd.

## Fuel consumption is high

Table 11-6 Fuel consumption is high

Cause		Remedies
Fuel system	Faulty fuel injection nozzle	♦Consult a dealer of Mitsubishi Heavy Industries, Ltd.
	Faulty fuel injection timing	♦Consult a dealer of Mitsubishi Heavy Industries, Ltd.
	Improper fuel property	♦Use appropriate fuel. ( <a href="#">Refer to P4-1</a> )
	Fuel leakage in fuel pipes and injection pipes.	♦Check faults and retighten fuel pipes and injection pipes. ♦Consult a dealer of Mitsubishi Heavy Industries, Ltd.
Cooling system	Overcooled	♦Check radiator. ( <a href="#">Refer to P8-13</a> ) ♦Check control system. ♦Thermostat - Inspect ♦Consult a dealer of Mitsubishi Heavy Industries, Ltd.
Inlet and exhaust systems	Insufficient amount of air	♦Clean, inspect and replace air cleaner element. ( <a href="#">Refer to P8-15</a> ) ♦Check intake air pressure and leakage of intake air. ♦Check intake air temperature and ventilation device. ♦Consult a dealer of Mitsubishi Heavy Industries, Ltd.
	Increase resistance of exhaust air.	♦Check exhaust pipes and silencer. ♦Consult a dealer of Mitsubishi Heavy Industries, Ltd.
Basic engine	Low compression pressure	♦Consult a dealer of Mitsubishi Heavy Industries, Ltd.
	Faulty valve timing	♦Consult a dealer of Mitsubishi Heavy Industries, Ltd.
	Rapid wear of sliding parts	♦Consult a dealer of Mitsubishi Heavy Industries, Ltd.

## Engine oil consumption is high

Table 11-7 Engine oil consumption is high

Cause		Remedies
Fuel system	Faulty fuel injection timing	♦Consult a dealer of Mitsubishi Heavy Industries, Ltd.
Lubricating system	Oil leakage to the outside of engine	♦Check oil leakage. ♦Consult a dealer of Mitsubishi Heavy Industries, Ltd.
	Engine oil viscosity too low	♦Use appropriate oil viscosity. <a href="#">(Refer to P5-3)</a>
	Engine oil temperature is high.	♦Check amount of engine oil and lubrication system. <a href="#">(Refer to P3-2)</a> ♦Consult a dealer of Mitsubishi Heavy Industries, Ltd.
Cooling system	Overheating	♦Check radiator. <a href="#">(Refer to P8-13)</a> ♦Check control system. ♦Thermostat - Inspect ♦Consult a dealer of Mitsubishi Heavy Industries, Ltd.
Inlet and exhaust systems	Spread oil to intake part	♦Consult a dealer of Mitsubishi Heavy Industries, Ltd.
	Wear of valve operating system	♦Consult a dealer of Mitsubishi Heavy Industries, Ltd.
Basic engine	Wear of sliding parts	♦Consult a dealer of Mitsubishi Heavy Industries, Ltd.
Control system	Increase in load	♦Check control system. ♦Consult a dealer of Mitsubishi Heavy Industries, Ltd.

## Overheating

Table 11-8 Overheating

Cause		Remedies
Cooling system	Low coolant level	<ul style="list-style-type: none"> <li>♦Check coolant leakage.</li> <li>♦Check coolant level. (<a href="#">Refer to P3-3</a>)</li> </ul>
	Faulty water pump operation	♦Consult a dealer of Mitsubishi Heavy Industries, Ltd.
	Faulty thermostat operation	♦Consult a dealer of Mitsubishi Heavy Industries, Ltd.
	Faulty radiator operation	<ul style="list-style-type: none"> <li>♦Check and clean radiator and radiator filler cap.</li> <li>(<a href="#">Refer to P8-13</a>)</li> </ul>
Control system	Increase in load	<ul style="list-style-type: none"> <li>♦Check fuel injection pump rack stroke.</li> <li>♦Check control system.</li> <li>♦Consult a dealer of Mitsubishi Heavy Industries, Ltd.</li> </ul>
Basic engine	Rapid wear of sliding parts	♦Consult a dealer of Mitsubishi Heavy Industries, Ltd.

## Low engine oil pressure

Table 11-9 Low engine oil pressure

Cause		Remedies
Lubricating system	Insufficient amount of engine oil	<ul style="list-style-type: none"> <li>♦Check amount of engine oil and lubrication system.</li> <li>(<a href="#">Refer to P3-2</a>)</li> </ul>
	Faulty engine oil property (viscosity)	<ul style="list-style-type: none"> <li>♦Analyze oil property. Use appropriate engine oil.</li> <li>(<a href="#">Refer to P5-1</a>)</li> </ul>
	Oil temperature too high	<ul style="list-style-type: none"> <li>♦Check coolant system.</li> <li>♦Consult a dealer of Mitsubishi Heavy Industries, Ltd.</li> </ul>
	Oil filter clogged	♦Inspect and replace oil filter. ( <a href="#">Refer to P8-7</a> )
	Faulty oil pump operation	♦Consult a dealer of Mitsubishi Heavy Industries, Ltd.
	Faulty relief valve operation	♦Consult a dealer of Mitsubishi Heavy Industries, Ltd.
Control system	Faulty pressure unit operation	<ul style="list-style-type: none"> <li>♦Check control system and wire.</li> <li>♦Consult a dealer of Mitsubishi Heavy Industries, Ltd.</li> </ul>
Basic engine	Increase in load	<ul style="list-style-type: none"> <li>♦Check control system.</li> <li>♦Consult a dealer of Mitsubishi Heavy Industries, Ltd.</li> </ul>
	Rapid wear of sliding parts	♦Consult a dealer of Mitsubishi Heavy Industries, Ltd.
	Increase clearance of sliding part.	♦Consult a dealer of Mitsubishi Heavy Industries, Ltd.

## When fuel has run out

When fuel runs out while engine is running and the engine has stopped, restart the engine as described below.

1. Return the starter switch to the "OFF" position.
2. Add fuel to the fuel tank.  
For filling fuel tank, refer to ["Fuel tank oil level - Check" \(3-2\)](#).
3. Bleed air from the fuel system.  
For bleeding fuel system, refer to ["Fuel system - Bleed air" \(8-3\)](#).
4. Restart the engine.  
For starting the engine, refer to ["Starting" \(3-4\)](#).



# Chapter 12 MAIN SPECIFICATIONS

## Main specifications

Table 12-1 Main specifications

Item		Specifications	
Engine model		L2E	L3E
Type		Vertical water cooled, 4 stroke cycle diesel engine	
No. of cylinders - arrangement		2 cylinder in-line	3 cylinder in-line
Cylinder bore × stroke		φ76 × 70 mm [2.99 x 2.76 in.]	φ76 × 70 mm [2.99 x 2.76 in.]
Displacement		0.635 L [0.2 U.S. gal.]	0.952 L [0.3 U.S. gal.]
Combustion type		Swirl chamber	
Compression ratio		23 : 1	
Firing order		1 - 2	1 - 3 - 2
Direction of rotation		Counterclockwise as viewed from flywheel side	
Dimensions (L x W x H)		417 × 418 × 500 mm [16.42 x 16.46 x 19.69 in.]	505 × 418 × 500 mm [19.88 x 16.34 x 19.69 in.]
Dry weight		Approx. 61 kg [134 lb.]	Approx. 75 kg [134 lb.]
Fuel		Diesel fuel (equivalent for JIS K 2204)	
Fuel injection pump		PER type	
Fuel filter		Cartridge or cock type paper-element	
Fuel injection nozzle		Throttle type	
Initial fuel injection pressure		13.73 MPa {140 kgf/cm <sup>2</sup> } [1991 psi]	
Lubrication method		Forced circulation (pressure feed by oil pump)	
Lubrication oil		Class CF or CH-4 oil (API service classification)	
Engine oil capacity	Standard Oil pan	Whole engine: Approx. 2.5 L [0.7 U.S. gal.], Oil pan Max/Min: Approx. 2.0 L [0.5 U.S. gal.]/Approx. 1.3 L [0.3 U.S. gal.]	Whole engine: Approx. 3.6 L [1.0 U.S. gal.], Oil pan Max/Min: Approx. 3.1 L [0.8 U.S. gal.]/Approx. 1.8 L [0.5 U.S. gal.]
	Deep type oil pan	-	Whole engine: Approx. 4.7 L [1.2 U.S. gal.], Oil pan Max/Min: Approx. 4.2 L [1.1 U.S. gal.]/Approx. 3.0 L [0.8 U.S. gal.]
Oil filter		Cartridge type paper-element	
Cooling method		Forced water cooling by centrifugal pump	
Coolant capacity		Approx. 1.2 L [0.3 U.S. gal.] (basic engine only)	Approx. 1.8 L [0.5 U.S. gal.] (basic engine only)
Starting system		Electric motor starting	
Starter		DC 12 V - 1.2 kW	DC 12 V - 1.7 kW
Alternator		DC 12 V - 40 A	

Note: (a) The specifications above are subject to change without prior notice.

(b) The specifications above are described for the standard model. The special model specifications may differ from these of standard model.

