

INSTRUCTION MANUAL

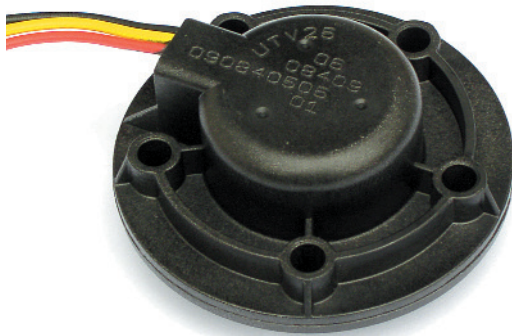

INTRODUCTION

the contactless measurement of a liquid level in a tank using ultrasonic technology does not require mobile parts any more to be gotten dirty or damaged.

- The ultrasonic sensor UTV emits an acoustic wave perpendicularly to the liquid surface and detects the reflection from the liquid surface.
- The distance from the sensor to the liquid's surface is computed based on the velocity of sound and the time between emission and reception of the waves. To get correct measurement, the waves must hit the liquid surface vertically ($\pm 6^\circ$).
- Fluctuations in the level of the liquid in the tank due to movements become balanced by a continuous measurement and a special computing algorithm.
- The ultrasonic sensors UTV are accurate to 1 cm. The off-zone is 5 cm from the undersurface of the sensor. This range cannot be measured and the output value could differ to the real filling level.
- In cases where it is not possible to fix the sensor parallel to the liquid surface, the optional focus tube can be used.
- The well sealed housing of the ultrasonic sensor is made of polyethylene, which withstands water, fuel and oil.



The ultrasonic sensor UTV can not be used for petrol tanks!

philippi elektrische systeme gmbh
Neckaraue 19
D-71686 Remseck am Neckar

www.philippi-online.de
info@philippi-online.de
Telefon: +49 (0)7146/8744-0, Fax -22

INSTALLATION

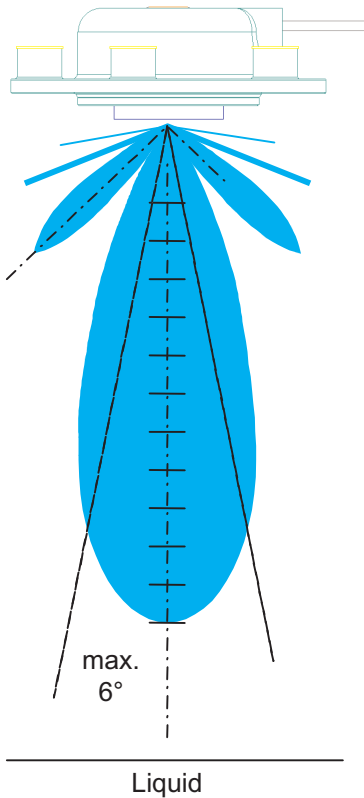

The ultrasonic sensor UTV has to be installed in a parallel position to the liquid, so that the acoustic wave hits the liquid surface vertically (difference max 6°).

In order to get best results and to avoid influences while heeling underway place the sensor in the center of the tank.

The ultrasonic tank sensors can be easily exchanged against an existing conventional tank sensor that has the attachment according to the SAE standard (5 mounting holes in the pitch diameter of 54 mm).

The hole in the tank for the installation of the ultrasonic sensor has to be min. 36 mm. (40 mm while using a focus tube).

The mounting height above the tank is 25mm. If the measurement is incorrect (e.g. in waste water tanks) or the boat is heeling you can install an optional focus tube UFT. It can be installed even afterwards. The tube has to be cut to a length 2 - 3 cm above the bottom of the tank.

It's ventilation hole is 5 cm under the sensor. Attention metal tanks: often the fixing screws are tightened too much. Then there's a risk of an acoustic feedback. In this case the sensor mostly gives a "full" signal (Voltage over 2,5 V). Eventually a second gasket has to be placed between the sensor and the tank.

SAE-NORM



The gasket and the (optional) distance ring match only in just one installation position. The gasket has a marking hole and a blind hole on one side. The side with the blind hole shows to the tank. The cable outlet is just over the marking hole. When using a distance ring, the marking has to be at the top and shows where the cable outlet sits.

ELEKTRISCHER ANSCHLUSS

The output signal of the ultrasonic sensor UTV is a voltage signal 0,5-2,5V.

Power supply is a voltage 10-30 V.

The black wire has to be connected to the minus (GND).

The red wire has to be connected to the terminal UTV (tankmonitor TCM) or to plus (10-30V).

The yellow wire gives the output signal (0,5-2,5V) and has to be connected to the terminal TG (1- 4) at the tank monitor TCM.

CONNECTION TO TCM

TUROTTEST-INSTRUMENTS
(Fuel-UTV, Water-UTV, Waste Water-UTV)

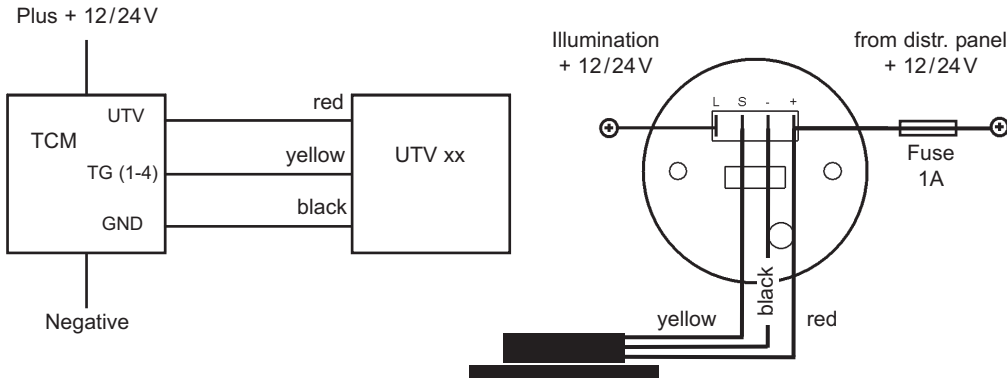

TAKE CARE The yellow sensor wire should never be connected to the supply power 12/24V - the sensor will be destroyed if so!

OPERATION

The power supply of the the tank measurement system should be switchable because the power consumption (ca. 50 mA/sensor) at permanent running is only reasonable while motoring. The exact output signal takes ca. 10-20s response time because the ultrasonic sensor is averaging the measurement results. Also fluctuations in the tank cause a delay by the averaging process (50s). If there are very fast level changes (e.g. from empty to full in 2s) the sensor doesn't react or only very slowly (it can take up to 7 min.), because the sensors interprets this as a mistake. The sensor shows the last „reasonable“ tank level. After 10 minutes of non-utilisable measurement values the sensor shows empty. If necessary interrupt the power supply of the sensor for 1 s. to restart the measurement. If the output signal doesn't change even if the filling level has changed, please check if the ultrasonic sensor is installed completely parallel to the liquid level and the acoustic wave is reflected vertically. Maybe you have to install a focus tube to get better results; please have a look at the installation chapter -page 2. The off-zone range is 5 cm underneath the sensor and the sensor cannot determine the correct level, if the liquid surface is in that zone. Due to this fact the output can differ to the real filling level.

TECHNICAL DATA

Power supply	11,5-30 V
Current consumption	50mA
Output signal	0,5V (=empty) until 2,5V (=full)
Response time	min. 200ms, max. 5s
Averaging time	10 - 50 sec.
Temperature range	-40°C bis +85°C

DIMENSIONS

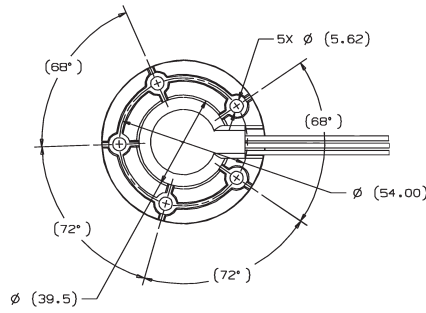
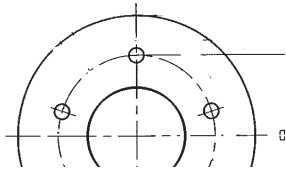

AVAILABLE SENSORS

for water, fuel (diesel), grey water and waste water tanks:

Tank depth	Order-no.	Focus tube: (incl. gasket)
200mm	7 0219 3520 UTV20	also for belated installation: UFT40 (400mm) 7 0219 9400
250mm	7 0219 3525 UTV25	UFT80 (800mm) 7 0219 9800
300mm	7 0219 3530 UTV30	
350mm	7 0219 3535 UTV35	
400mm	7 0219 3540 UTV40	
450mm	7 0219 3545 UTV45	
500mm	7 0219 3550 UTV50	
600mm	7 0219 3560 UTV60	
700mm	7 0219 3570 UTV70	
800mm	7 0219 3580 UTV80	

The focus tube has to be cut to a length to 2-3 cm above the bottom of the tank.



DISTANCE RING to balance the offzone:



incl. gasket & stainless steel screws:
 7 0219 9025 UTS 25 (5x M5 x 60 mm)
 7 0219 9050 UTS 50 (5x M5 x 80 mm)



Take care of installation sequence

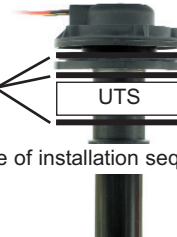

MATCHING ANALOG GAUGES for operation at 12V and 24V:



2 0778 2001 Water UTV
 2 0778 2021 Fuel UTV
 2 0778 2041 Waste Water UTV

DISPOSAL NOTE



Please take care of your local directives on waste electrical and electronic equipment.
 Please use collection points for waste electrical and electronic equipment.