

Workshop Manual

Engine unit

A
2 (0)

MD6A, MD7A



AB Volvo Penta
Customer Support
Dept. 42200
SE-405 08 Gothenburg
Sweden

**VOLVO
PENTA**

Workshop Manual

Marine diesel engines MD6A, MD7A

Contents

Safety Precautions	2
General information	5
Repair methods	6
Presentation	
MD6A	8
MD7A	9
Repair instructions	10
Electrical system	30
Special Tools	34
Technical Data	35

Safety Precautions

Introduction

This workshop manual contains technical data, descriptions and repair instructions for Volvo Penta products or product versions contained in the contents list. Ensure that the correct workshop literature is being used.

Read the safety information and the Workshop Manual “General Information” and “Repair Instructions” carefully before starting work.

Important

In this book and on the engine you will find the following special warning symbols.

 **WARNING!** If these instructions are not followed there is a danger of personal injury, extensive damage to the product or serious mechanical malfunction.

 **IMPORTANT!** Used to draw your attention to something that can cause damage, product malfunction or damage to property.

NOTE! Used to draw your attention to important information that will facilitate work or operations.

Below is a summary of the risks and safety precautions you should always observe or carry out when operating or servicing the engine.

 Immobilize the engine by turning off the power supply to the engine at the main switch(es) and lock it (them) in the OFF position before starting work. Set up a warning notice at the engine control point or helm.

 Generally, all servicing should be carried out with the engine switched off. Some work (carrying out certain adjustments for example) requires the engine to be running. Approaching a running engine is dangerous. Loose clothing or long hair can fasten in rotating parts and cause serious personal injury. If working in proximity to a running engine, careless movements or a dropped tool can result in personal injury. Avoid burns. Take precautions to avoid hot surfaces (exhausts, turbochargers, charge air pipes and starter elements, etc.) and liquids in supply lines and hoses when the engine is running or has been turned off immediately prior to starting work on it. Reinstall all protective parts removed during service operations before starting the engine.

 Check that the warning information decals on the product are always clearly visible. Replace decals that have been damaged or painted over.

 Engine with turbocharger: Never start the engine without installing the air cleaner (ACL). The rotating compressor in the Turbo can cause serious personal injury. Foreign objects entering the intake ducts can also cause mechanical damage.

 Never use start spray or similar to start the engine. The starter element may cause an explosion in the inlet manifold. Danger of personal injury.

 Avoid opening the filler cap for engine coolant system (freshwater cooled engines) when the engine is still hot. Steam or hot coolant can spray out. Open the coolant filler cap carefully and slowly to release pressure before removing the cap completely. Take great care if a cock, plug or engine coolant line must be removed from a hot engine. It is difficult to anticipate in which direction steam or hot coolant can spray out.

 Hot oil can cause burns. Avoid skin contact with hot oil. Ensure that the lubrication system is not under pressure before commencing work on it. Never start or operate the engine with the oil filler cap removed, otherwise oil could be ejected.

 Stop the engine and close the sea cock before carrying out operations on the engine cooling system.

 Only start the engine in a well-ventilated area. If operating the engine in an enclosed space, ensure that exhaust gases and crankcase ventilation emissions are ventilated out of the working area.



Always use protective goggles where there is a danger of pieces of metal, sparks from grinding, acid or other chemicals being thrown into your eyes. Your eyes are very sensitive, injury can lead to loss of sight!



Avoid skin contact with oil. Long-term or repeated contact with oil can remove the natural oils from your skin. The result can be irritation, dry skin, eczema and other skin problems. Used oil is more dangerous to health than new oil. Use protective gloves and avoid using oil-soaked clothes and rags. Wash regularly, especially before meals. Use the correct barrier cream to prevent dry skin and to make cleaning your skin easier.



Most chemicals used in products (engine and transmission oils, glycol, petrol and diesel oil) and workshop chemicals (solvents and paints) are hazardous to health. Read the instructions on the product packaging carefully! Always follow safety instructions (using breathing apparatus, protective goggles and gloves for example). Ensure that other personnel are not unwittingly exposed to hazardous substances (by breathing them in for example). Ensure that ventilation is good. Handle used and excess chemicals according to instructions.



Be extremely careful when tracing leaks in the fuel system and testing fuel injection nozzles. Use protective goggles! The jet ejected from a fuel injection nozzle is under very high pressure, it can penetrate body tissue and cause serious injury. There is a danger of blood poisoning.



All fuels and many chemicals are inflammable. Ensure that a naked flame or sparks cannot ignite fuel or chemicals. Combined with air in certain ratios, petrol, some solvents and hydrogen from batteries are easily inflammable and explosive. Smoking is prohibited! Ensure that ventilation is good and that the necessary safety precautions have been taken before carrying out welding or grinding work. Always have a fire extinguisher to hand in the workplace.



Store oil and fuel-soaked rags and fuel and oil filters safely. In certain conditions oil-soaked rags can spontaneously ignite. Used fuel and oil filters are environmentally dangerous waste and must be deposited at an approved site for destruction together with used lubricating oil, contaminated fuel, paint remnants, solvent, degreasing agents and waste from washing parts.



Never allow a naked flame or electric sparks near the batteries. Never smoke in proximity to the batteries. The batteries give off hydrogen gas during charging which when mixed with air can form an explosive gas - oxyhydrogen. This gas is easily ignited and highly volatile. Incorrect connection of the battery can cause a spark which is sufficient to cause an explosion with resulting damage. Do not disturb battery connections when starting the engine (spark risk) and do not lean over batteries.



Never mix up the positive and negative battery terminals when installing. Incorrect installation can result in serious damage to electrical equipment. Refer to wiring diagrams.



Always use protective goggles when charging and handling batteries. The battery electrolyte contains extremely corrosive sulfuric acid. If this comes into contact with the skin, wash immediately with soap and plenty of water. If battery acid comes into contact with the eyes, immediately flush with copious amounts of water and obtain medical assistance.



Turn off the engine and turn off power at main switch(es) before carrying out work on the electrical system.



Clutch adjustments must be carried out with the engine turned off.



Use the lifting eyes mounted on the engine/reverse gear when lifting the drive unit. Always check that lifting equipment is in good condition and has sufficient load capacity to lift the engine (engine weight including reverse gear and any extra equipment installed). To ensure safe handling and to avoid damaging engine components on top of the engine, use a lifting beam to raise the engine. All chains and cables should run parallel to each other and as perpendicular as possible in relation to the top of the engine. If extra equipment is installed on the engine altering its center of gravity, a special lifting device is required to achieve the correct balance for safe handling. Never carry out work on an engine suspended on a hoist.



Never remove heavy components alone, even where secure lifting equipment such as secured blocks are being used. Even where lifting equipment is being used it is best to carry out the work with two people; one to operate the lifting equipment and the other to ensure that components are not trapped and damaged when being lifted.



When working on-board ensure that there is sufficient space to remove components without danger of injury or damage.



Components in the electrical system, ignition system (gasoline engines) and fuel system on Volvo Penta products are designed and constructed to minimize the risk of fire and explosion. The engine must not be run in areas where there are explosive materials.



Always use fuels recommended by Volvo Penta. Refer to the Instruction Book. The use of lower quality fuels can damage the engine. On a diesel engine poor quality fuel can cause the control rod to seize and the engine to over-rev with the resulting risk of damage to the engine and personal injury. Poor fuel quality can also lead to higher maintenance costs.

General information

About the workshop manual

This workshop manual contains technical specification, descriptions and instructions for repairing the standard versions of the following engines TAMD31M, TAMD31L, TAMD31P, AD31L, AD31P, KAD32P, TAMD41H, TAMD41M, TAMD41P, AD41P, TAMD42WJ, KAMD42A, KAMD42B, KAMD42P, KAD42A, KAD42B, KAD42P, KAMD43P, KAD43P, KAMD44P, KAD44P. The workshop manual displays the operations carried out on any of the engines above. As a result the illustrations and pictures in the manual that show certain parts on the engines, do not in some cases apply to all the engines listed above. However the repair and service operations described are the same in all essential details. Where they are not the same this is stated in the manual and where the difference is considerable the operations are described separately. Engine designations and numbers are given on the number plate (See Workshop manual Group 21 Engine page 15). The engine designation and number should be given in all correspondence about the engine.

This Workshop Manual has been developed primarily for Volvo Penta service workshops and qualified personnel. Persons using this book are assumed to have a grounding in marine drive systems and be able to carry out related mechanical and electrical work.

Volvo Penta is continuously developing their products. We therefore reserve the right to make changes. All the information contained in this book is based on product data available at the time of going to print. Any essential changes or modifications introduced into production or updated or revised service methods introduced after the date of publication will be provided in the form of Service Bulletins.

Replacement parts

Replacement parts for electrical and fuel systems are subject to statutory requirements (US Coast Guard Safety Regulations for example). Volvo Penta Genuine parts meet these requirements. Any type of damage which results from the use of non-original Volvo Penta replacement parts for the product will not be covered under any warranty provided by Volvo Penta.

Certified engines

The manufacturer guarantees that certified new and currently operational engines meet national and regional environmental regulations (in Lake Constance for example). The product must be the same as the example approved for certification purposes. So that Volvo Penta, as a manufacturer, can guarantee that currently operational engines meet environmental regulations, the following service and replacement part requirements must be observed:

- The Service Intervals and maintenance operations recommended by Volvo Penta must be observed.
- Only Volvo Penta genuine replacement parts, intended for the certificated engine, may be used.
- The servicing of ignition, timing and fuel injection systems (gasoline) or injector pumps, pump settings and injectors (diesel) must always be carried out by an authorized Volvo Penta workshop.
- The engine must not be modified in any way apart from with accessories and service kits developed for it by Volvo Penta.
- No modifications to the exhaust pipes and air supply ducts for the engine room (ventilation ducts) may be undertaken as this may effect exhaust emissions.
- Seals may only be broken by authorized personnel.

IMPORTANT! Use only Volvo Penta Genuine Parts.

Use of non-original AB Volvo Penta spare parts will result in AB Volvo Penta being unable to assume liability for the engine meeting engine certification requirements.

Any type of damage resulting from the use of non-original Volvo Penta replacement parts for the product will not be covered under any warranty provided by AB Volvo Penta.

Repair methods

The working methods described in the Service Manual apply to work carried out in a workshop. The engine has been removed from the boat and is installed in an engine fixture. Unless otherwise stated reconditioning work which can be carried out with the engine in place follows the same working method.

Warning symbols occurring in the Workshop Manual (for their meaning see *Safety information*)



NOTE!

are not in any way comprehensive since it is impossible to predict every circumstance under which service work or repairs may be carried out. For this reason we can only highlight the risks that can arise when work is carried out incorrectly in a well-equipped workshop using working methods and tools developed by us.

All procedures for which there are Volvo Penta special tools in this Workshop Manual are carried out using these. Special tools are developed to rationalize working methods and make procedures as safe as possible. It is therefore the responsibility of any person using tools or working methods other than the ones recommended by us to ensure that there is no danger of injury, damage or malfunction resulting from these.

In some cases there may be special safety precautions and instructions for the use of tools and chemicals contained in this Workshop Manual. These special instructions should always be followed if there are no separate instructions in the Workshop Manual.

Certain elementary precautions and common sense can prevent most risks arising. A clean workplace and engine eliminates much of the danger of injury and malfunction.

It is of the greatest importance that no dirt or foreign particles get into the fuel system, lubrication system, intake system, turbocharger, bearings and seals when they are being worked on. The result can be malfunction or a shorter operational life.

Our joint responsibility

Each engine consists of many connected systems and components. If a component deviates from its technical specification the environmental impact of an otherwise good engine may be increased significantly. It is therefore vital that wear tolerances are maintained, that systems that can be adjusted are adjusted properly and that Volvo Penta Genuine Parts as used. The engine Maintenance Schedule must be followed.

Some systems, such as the components in the fuel system, require special expertise and special testing equipment for service and maintenance. Some components are sealed at the factory for environmental reasons. No work should be carried out on sealed components except by authorized personnel.

Bear in mind that most chemicals used on boats are harmful to the environment if used incorrectly. Volvo Penta recommends the use of biodegradable degreasing agents for cleaning engine components, unless otherwise stated in a workshop manual. Take special care when working on-board, that oil and waste is taken for destruction and is not accidentally pumped into the environment with bilge water.

Tightening torques

Tightening torques for vital joints that must be tightened with a torque wrench are listed in workshop manual 'Technical Data': "Tightening Torques" and are contained in work descriptions in this Manual. All torques apply for cleaned threads, screw heads and mating surfaces. Torques apply for lightly oiled or dry threads. If lubricants, locking fluid or sealing compound are required for a screwed joint this information will be contained in the work description and in "Tightening Torques" Where no tightening torque is stated for a joint use the general tightening torques according to the tables below. The tightening torques stated are a guide and the joint does not have to be tightened using a torque wrench.

Dimension	Tightening Torques	
	Nm	lbt.ft
M5	6	4,4
M6	10	7,4
M8	25	18,4
M10	50	36,9
M12	80	59,0
M14	140	103,3

Tightening torques-protractor (angle) tightening



Tightening using both a torque setting and a protractor angle requires that first the recommended torque is applied using a torque wrench and then the recommended angle is added according to the protractor scale. Example: a 9Q0 protractor tightening means that the joint is tightened a further 1/4 turn in one operation after the stated tightening torque has been applied.

Locknuts

Do not re-use lock nuts that have been removed during dismantling as they have reduced service life when re-used - use new nuts when assembling or re-installing. For lock nuts with a plastic insert such as Nylock® the tightening torque stated in the table is reduced if the Nylock® nut has the same head height as a standard hexagonal nut without plastic insert. Reduce the tightening torque by 25% for bolt size 8 mm or larger. Where Nylock® nuts are higher, or of the same height as a standard hexagonal nut, the tightening torques given in the table apply.

Tolerance classes

Screws and nuts are divided into different strength classes, the class is indicated by the number on the bolt head. A high number indicates stronger material, for example a bolt marked 10-9 indicates a higher tolerance than one marked 8-8. It is therefore important that bolts removed during the disassembly of a bolted joint must be reinstalled in their original position when assembling the joint, It a bolt must be replaced check in the replacement parts catalogue to make sure the correct bolt is used.

Sealants

A number of sealants and locking liquids are used on the engines. The agents have varying properties and are used for different types of jointing strengths, operating temperature ranges, resistance to oil and other chemicals and for the different materials and gap sizes in the engines.

To ensure service work is correctly carried out it is important that the correct sealant and locking fluid type is used on the joint where the agents are required.

In this Volvo Penta Service Manual the user will find that each section where these agents are applied in production states which type was used on the engine.

During service operations use the same agent or an alternative from a different manufacturer.

Make sure that mating surfaces are dry and free from oil, grease, paint and anti-corrosion agent before applying sealant or locking fluid.

Always follow the manufacturer's instructions for use regarding; temperature range, curing time and any other instructions for the product.

Two different basic types of agent are used on the engine and these are:

RTV agent (Room temperature vulcanizing). Use for gaskets, sealing gasket joints or coating gaskets. RTV agent is clearly visible when a component has been dismantled; old RTV must be removed before the joint is resealed.

The following RTV agents are mentioned in the Service Manual: Loctite® 574, Volvo Penta 840879-1, Permatex®

No. 3, Volvo Penta P/N 1161099-5, Permatex® No. 77. Old sealant can be removed using methylated spirits in all cases.

Anaerobic agents. These agents cure in an absence of air. They are used when two solid parts, for example cast components, are installed face-to-face without a gasket. They are also commonly used to secure plugs, threads in stud bolts, cocks, oil pressure switches and so on. The cured material is glass-like and it is therefore colored to make it visible. Cured anaerobic agents are extremely resistant to solvents and the old agent cannot be removed. When reinstalling the part is carefully degreased and then new sealant is applied.

The following anaerobic agents are mentioned in the Service Manual: Loctite® 572 (white), Loctite® 241 (blue).

NOTE! Loctite® is the registered trademark of Loctite Corporation, Permatex® is the registered trademark of the Permatex Corporation.

Presentation

MD6A

1. Recess for starting crank
2. Oil filling, engine
3. Sealed crankcase ventilation
4. Intake silencer
5. Connection, fuel inlet
6. Feed pump
7. Reduction reverse gear MS, red. 1.91:1
8. Control lever, reverse gear
9. Oil filling, reverse gear
10. Oil pressure contact
11. Lubricating oil filter
12. Start-generator
13. Fuel filter
14. Water-cooled exhaust manifold
15. Decompression handle
16. Injectors
17. Temperature sender
18. Cooling water outlet
19. Thermostat housing
20. Throttle lever
21. Stop lever
22. Fuel injection pump
23. Oil dipstick, engine
24. Fuel return line connection
25. Sea-water pump
26. Oil dipstick, reverse gear

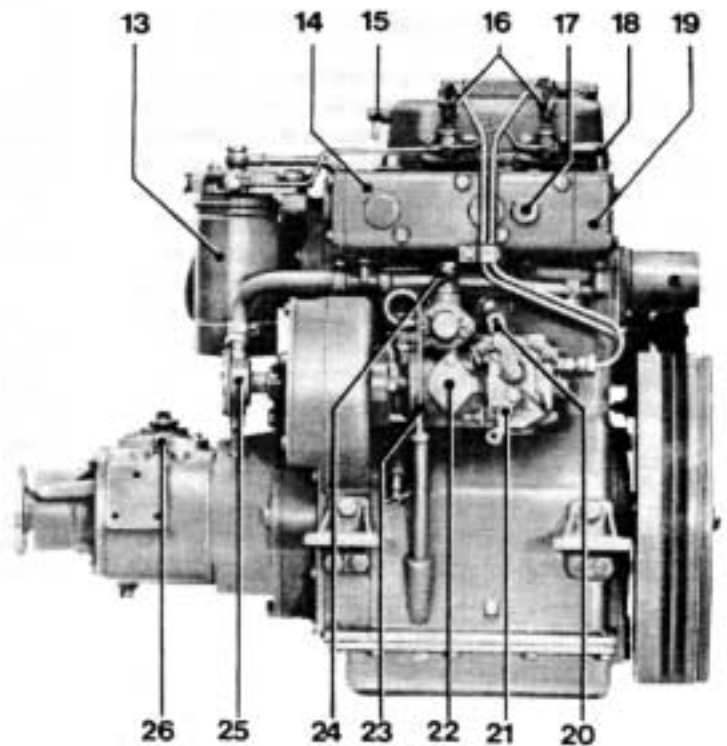
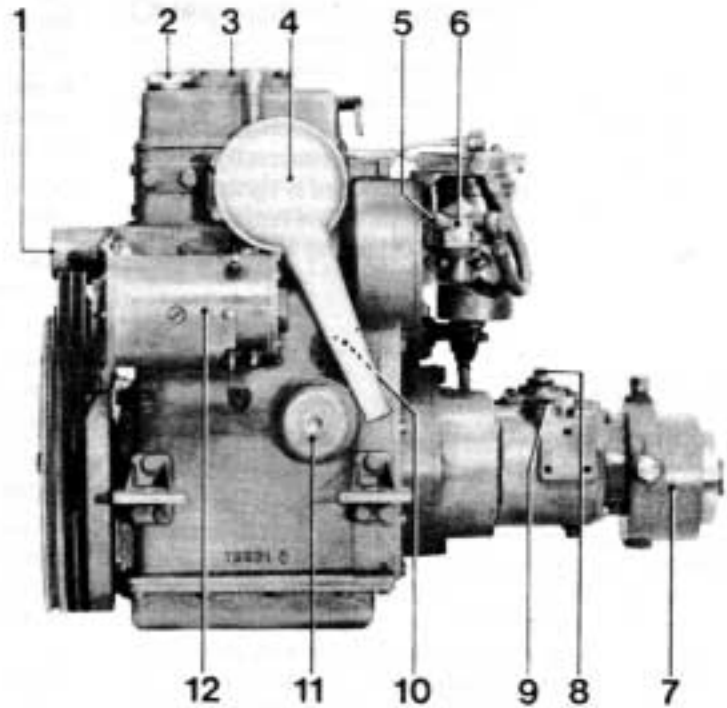

MD7A

1. Oil dip-stick and oil filling, reverse gear
2. Cover, cooling water pump
3. Bleed-screw, fine filter
4. Fine filter
5. Decompression handle
6. Pressure pipe nut
7. Temperature sender
8. Injector
9. Thermostat housing
10. Oil filling, engine
11. Hand start
12. Cooling water drain, engine
13. Fuel injection pump
14. Oil dip-stick, engine
15. Cooling water drain, reverse gear
16. Air cleaner and intake silencer
17. Sender, rev, counter
18. Fuel pump (with hand pump)
19. Cooling water inlet, reduction gear
20. Oil drain, reverse gear, reduction gear
21. Warner, low oil pressure
22. Oil filter

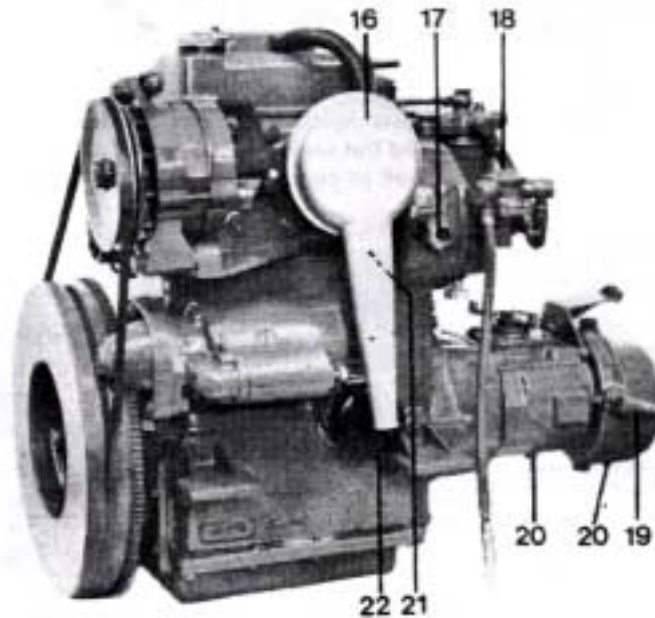
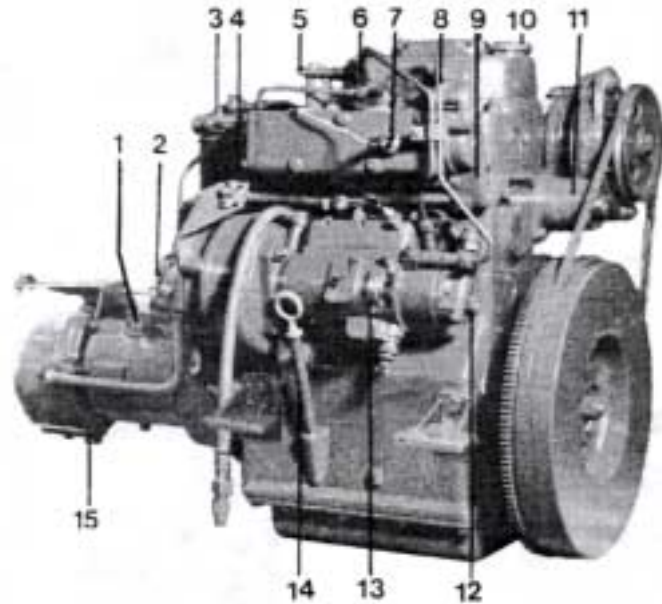

Repair instructions

Drain the cooling water and oil from the engine. Then clean the outside of the engine. Remove the reverse gear, 4 bolts.

Removal

1. Remove the air cleaner, disconnect the alternator electric cables and the oil pressure cable, remove the alternator and the drive belts. Then remove the sea-water pump, the oil filter, the fuel filter and the feed pump. (Look out for fuel and oil splash.)

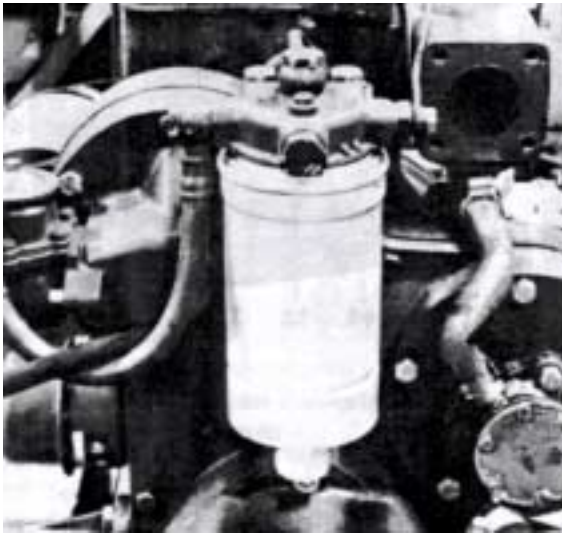

2. Remove the injectors and pipes as well as the leak-off oil pipe. Discard the sealing washers on both sides of the leak-off oil pipe.

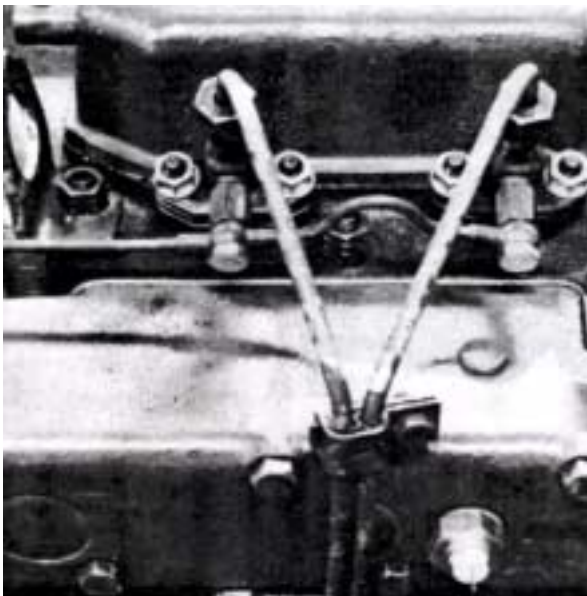

3. Remove the thermostat housing (2 bolts) and the hose clamp under the housing. Take the thermostat out of the exhaust manifold. Note the small O-ring which seals against the exhaust manifold.

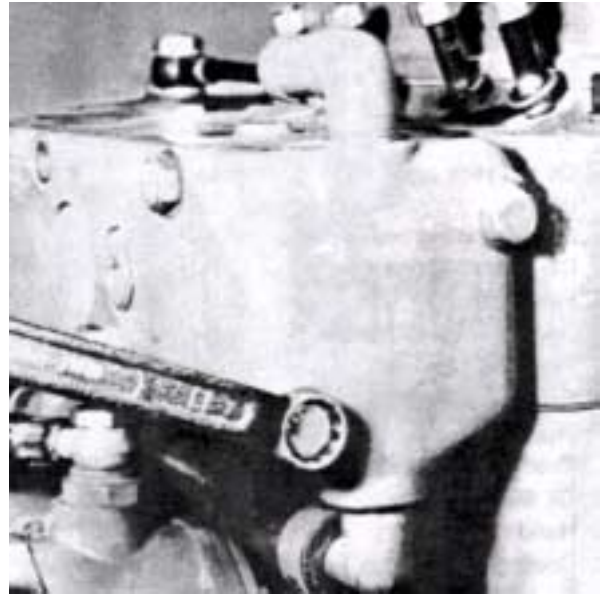

4. Remove the exhaust manifold (4 bolts).

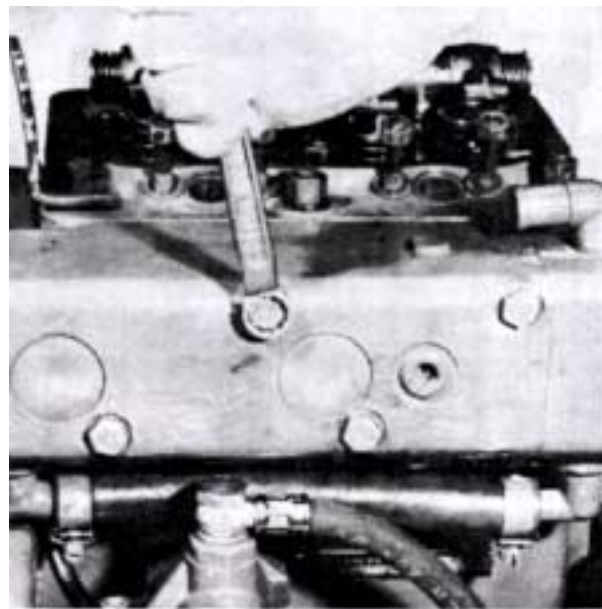

5. Remove the rocker arm cover (2 nuts), the intake manifold (4 bolts), the rocker arm (2 nuts) and the cylinder head (9 bolts). Take care of the washers.



7. a. (BOSCH pump) Disconnect the pipe from the fuel filter and remove the nuts for the fuel injection pump.

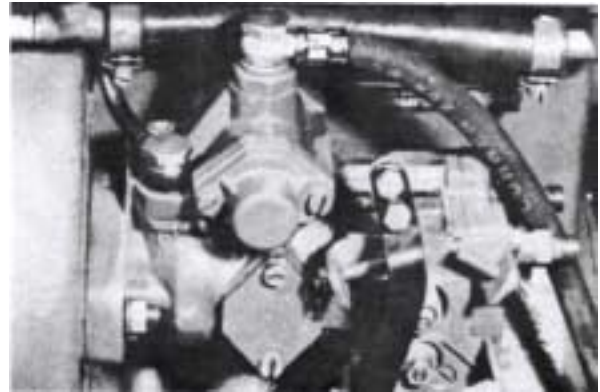

7. b. (CAV pump) Disconnect the pipe from the fuel filter and remove the nuts for the fuel injection pump.

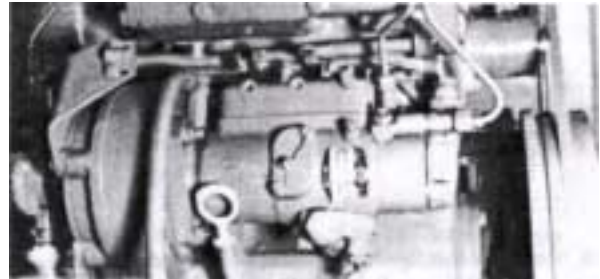

6. Remove the cover on which the water pump is mounted. NOTE! Two of the five bolts are shorter than the other three and are placed towards the centre of the engine. Take care of the control bracket. Discard the old gasket.

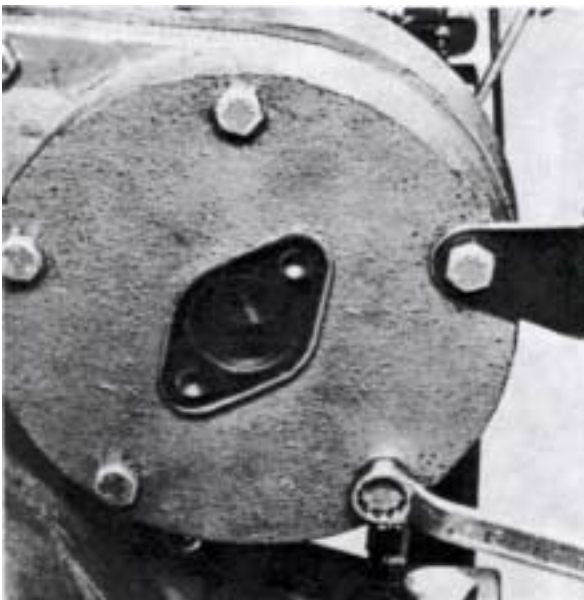

8. Remove the nut which drives the water pump. Use the flywheel as a counterhold. Remove the fuel injection pump and the gear wheel.

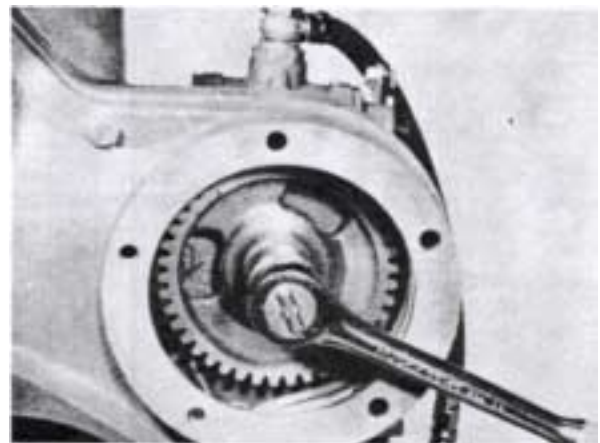

9. Remove the timing gear cover. NOTE! The small round cover on which the fuel pump is mounted has bolts with 3 different lengths. The bolts for the large casing has two lengths. The bolts for the large casing has two lengths. The two bottom bolts are shorter than the others. Carefully lever loose the timing gear casing from its guide pins. Discard the gasket.

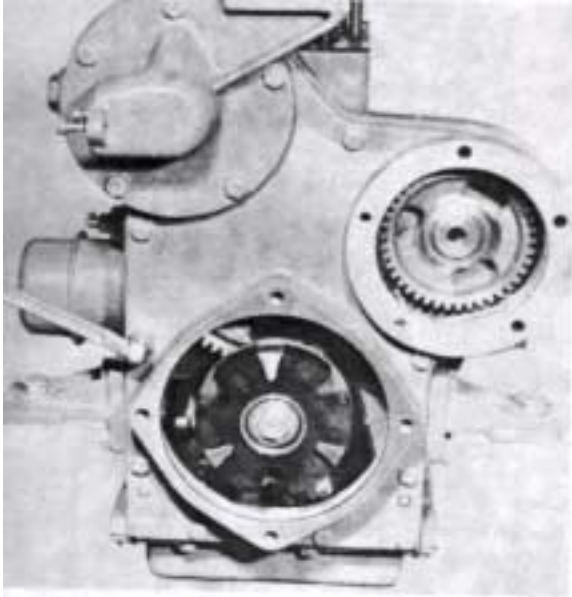

11. Knock out the hand starter pin in the camshaft. Remove the protective cover (2 bolts). NOTE! Scrap the sealing ring and fit a new one.

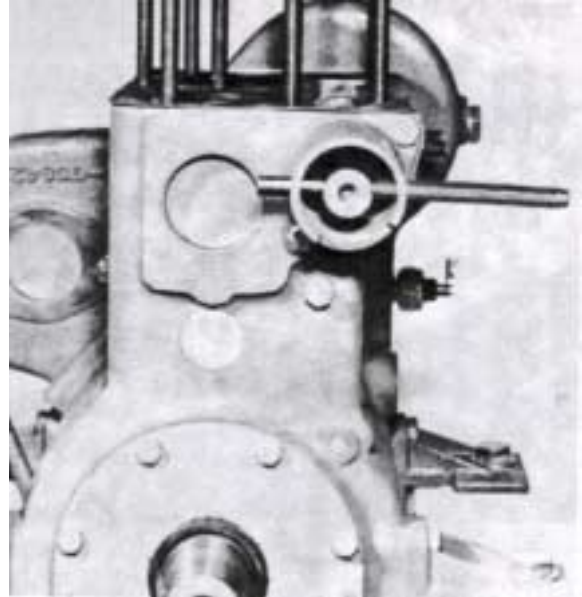

10. Remove the flywheel. Remove the nut and use a puller. The axle is tapered and provided with a key. Use a counterhold when releasing the nut.

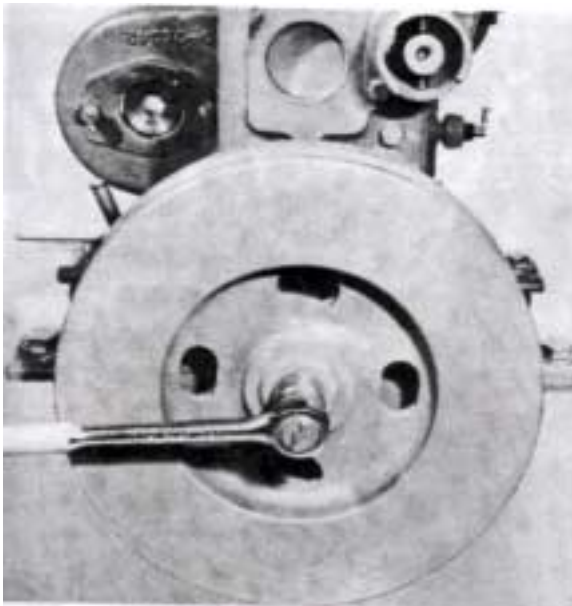

12. Remove the front cover behind the flywheel (11 bolts). Note the guide pins. Carefully tap all round. Replace the gasket and the sealing ring.

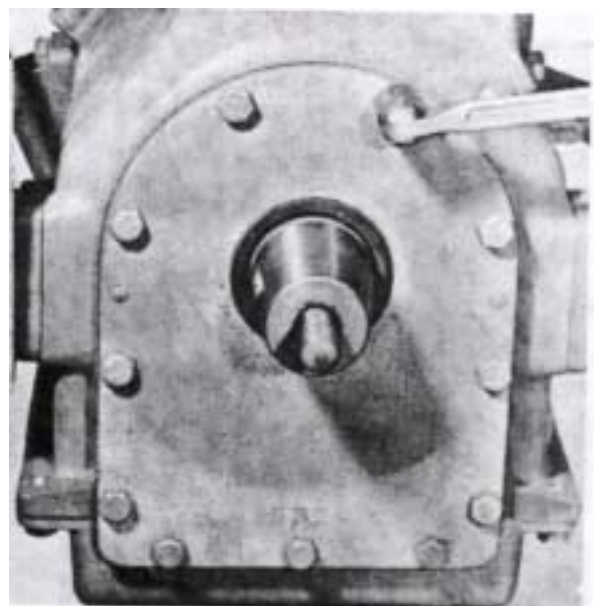

13. Remove the sump as well as the nut and lock washer for the camshaft. Use a counterhold on the crankshaft.

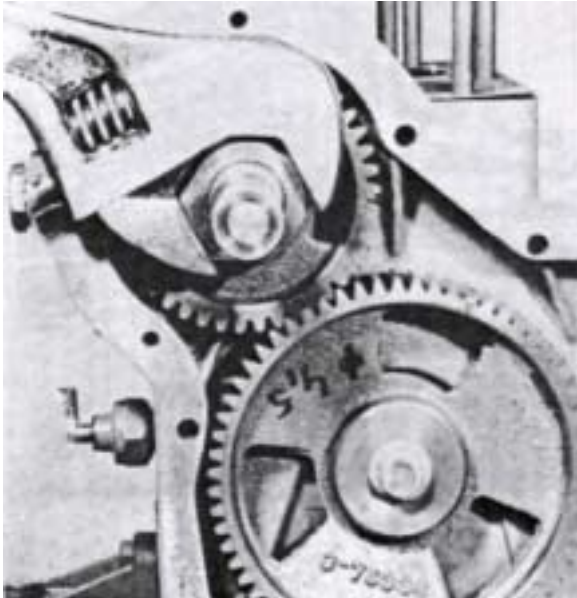

15. Remove the bolt for the intermediate gear. Discard the sealing washer 1 under the bolt. Pull off the intermediate gear.

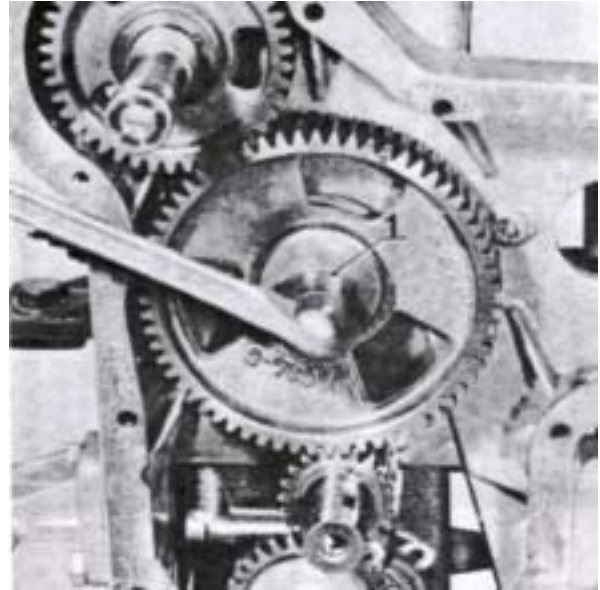

14. Bend down the lock washer and release the bolt securing the reverse gear flange to the crankshaft. Use a counterhold. NOTE! Take care of the key. Lever loose the rubber damper with a screwdriver.

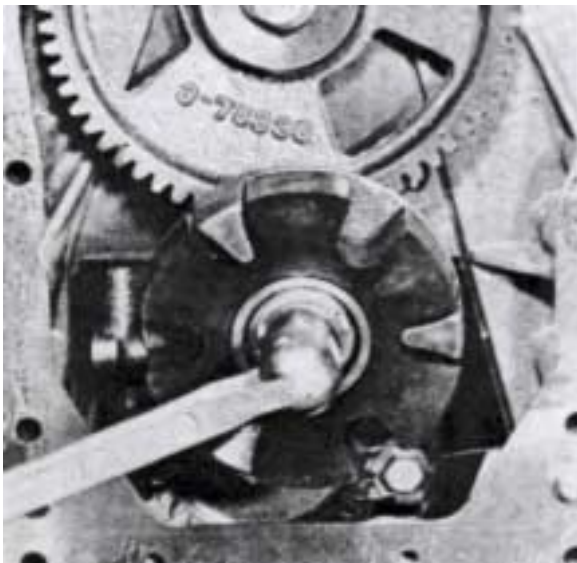

16. Check that the shaft pin 1 for the intermediate gear is secure.

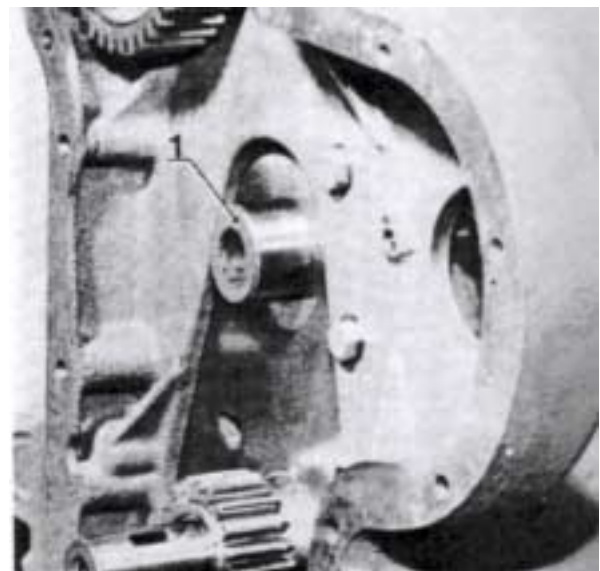

17. Remove the gearwheel for the camshaft by tapping the camshaft on the flywheel side with a plastic mallet or similar tool. Lift out the shaft and take care of the cover.

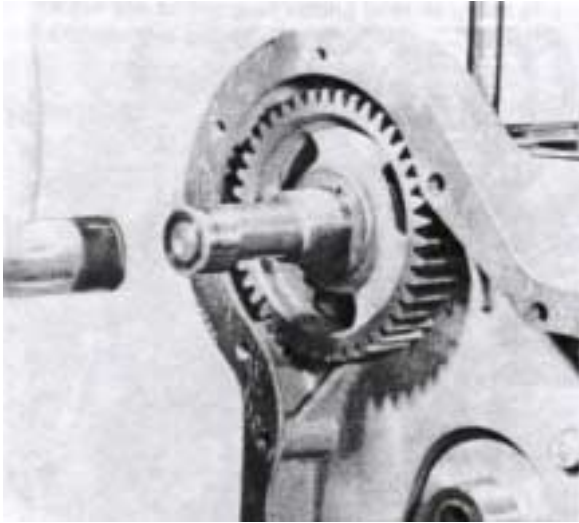

19. Invert the engine and remove the oil strainer (2 bolts and 1 nut).

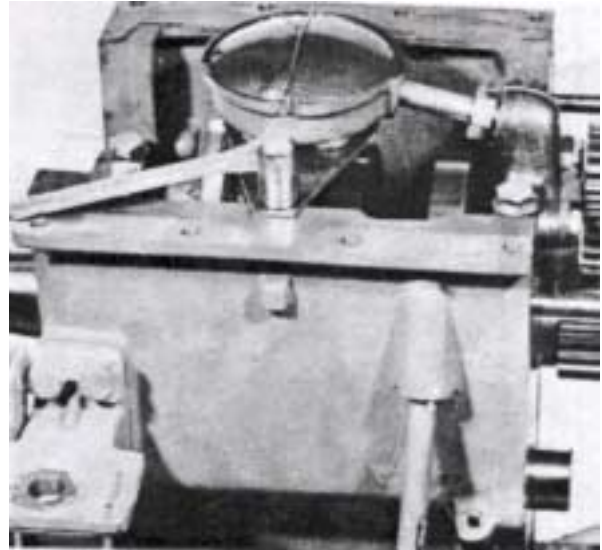

18. Remove the 4 bolts holding the timing gear casing. The casing also sits on guides. Carefully lever all round and remove the casing.

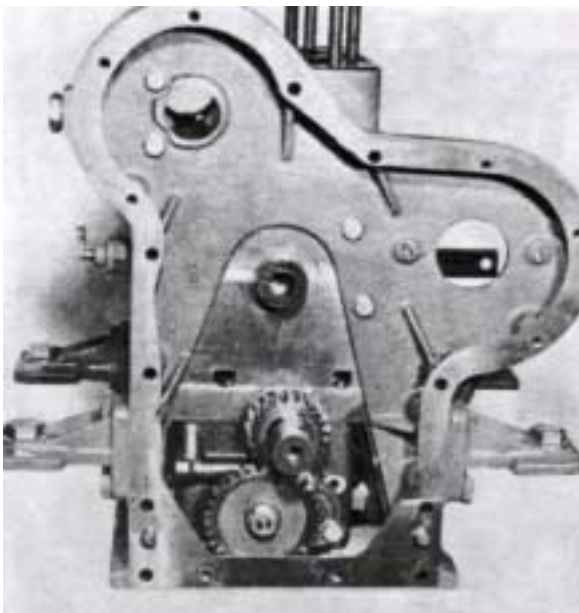

20. Unscrew the bolts and remove the caps. Then carefully tap out the pistons and connecting rods. Place connection rods and caps in the same pairing as when removed to prevent them getting mixed up if they are not marked. NOTE! Also mark the piston and connecting rod for the respective cylinders (see point 21). On earlier engines there is no marking on the pistons and connecting rods. During overhauling, these engines must be marked in the same way as those produced later on.



21. Mark the connecting rod and cap nearest the flywheel with a peener. Peen as shown in Fig. 21.



23. Remove the centre nut and washer for the gear wheel on the lubricating oil pump. The shaft is tapered and the gear wheel sits on a key.



22. Remove the main bearing caps and lubricating oil pump.
The main bearing caps are marked with a 2 or 3. The corresponding figures are punched into the block. Replace the axial bearings 1. Check that the guide 2 for the caps is in good condition. Lift out the crankshaft.



24. Remove the bolts (4) from the pump body cover and lift off the cover. Clean the body and check that the gears are in good condition. Replace damaged parts.

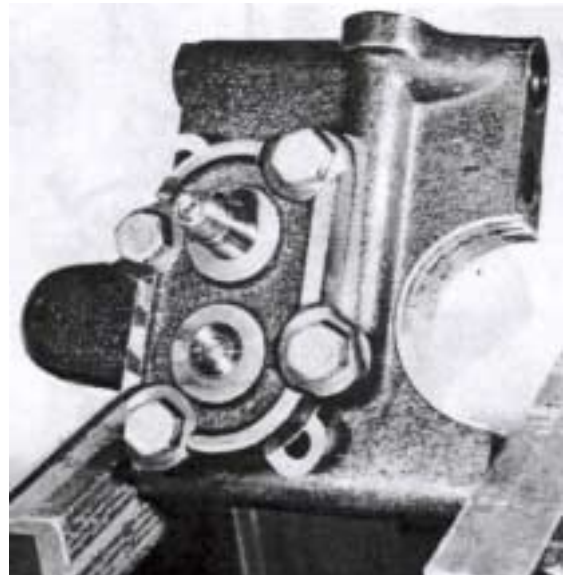

25. Re-fit the gears as shown in the Fig. below. Fit the cover together with a new gasket. Tighten up the 4 bolts and rotate the shaft to make sure that it does not jam. Fit the key in its groove and re-fit the gear wheel. Fit the spring washer and tighten up the gear with the nut.

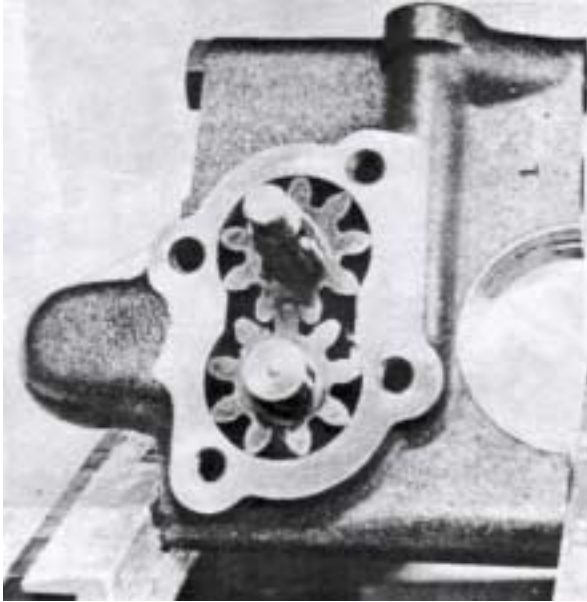

27. Check for wear on pistons, piston rings and gudgeon pins. Replace if necessary. The piston and connecting rod must be matchfitted as shown in fig. A. Make absolutely certain that the groove ring for the gudgeon pin is fitted in its groove. The piston rings are fitted with a piston ring rod. Begin with the oil ring 1 (fig B) in the lowest groove. Continue with the compression ring 2. Finally fit the compression ring 3. NOTE! The marking TOP must face upwards. The other two rings can be faced as desired.

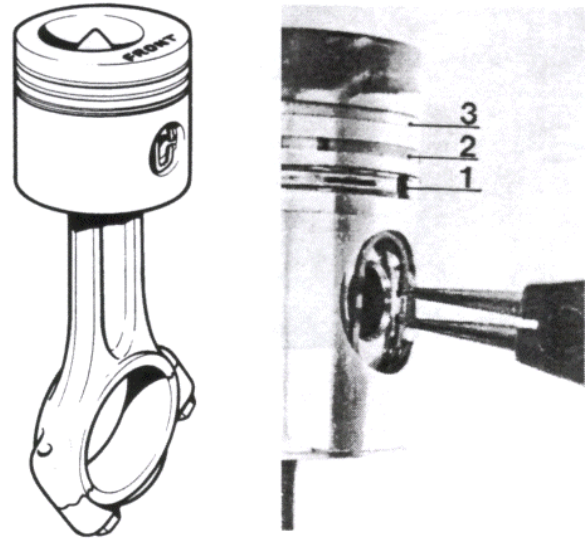

26. Remove the bolt 1 for the relief valve and check that the spring 2 and piston are in good condition. If there is anything suspicious about the opening pressure of the relief valve, check the data for the spring. See under "Technical Data, Lubricating oil pump". Clean and re-fit the piston and spring and tighten up the bolt.

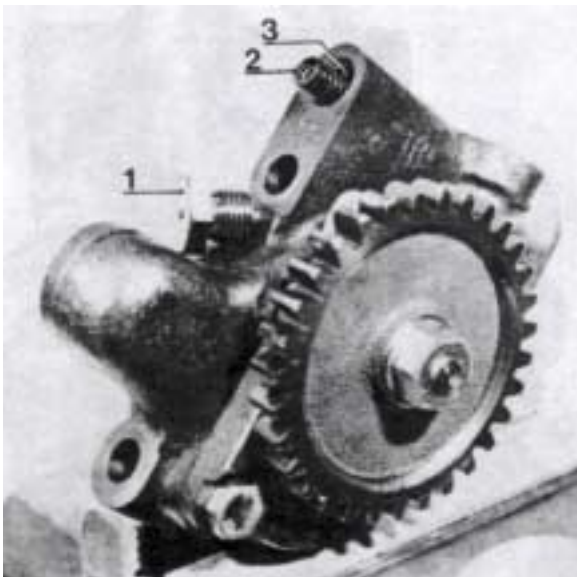

Crankshaft

28. Check the drive gear on the crankshaft for wear or damage. Remove the drive gear with a puller. Remove the key and clean the shaft. Check for wear and grind the shaft if necessary. (See under "Technical Data".) Clean the engine block and all other parts which must be re-fitted.

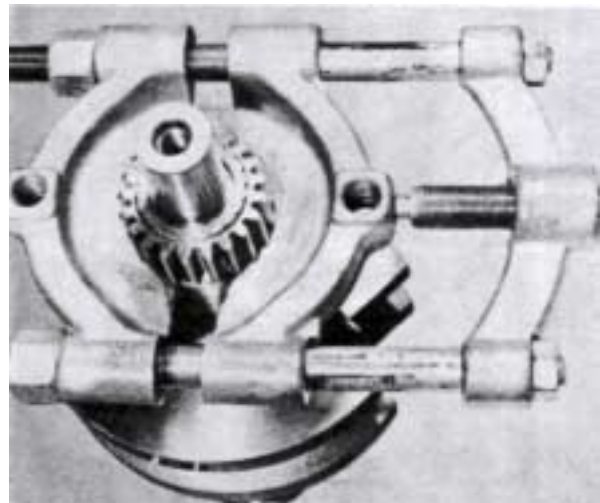

Cylinder head

29. Remove the valve tappets. NOTE! Carefully machine clean the valve tappets where they have been smoothed down (1) in order to serve as a counterhold for the torque wrench. Do not force out the valve tappets as this could damage the block etc.



31. Replacing the valve guides.
With excessive clearance between the valve stem and valve guide, the valve guide must be replaced. (See under "Technical Data".) Press out the valve guides with tool 884538.



30. Remove the seals on the valve stems. Remove the valve springs with the help of a valve spring remover. Remove all the collets 1. Remove the valves. IMPORTANT! Place the valves in the order in which they are removed. Discard burnt valves if the wear is excessive and grind valve seats if necessary (See under Technical Data). Seats and valves must be ground together so that the contact surfaces will be absolutely tight.



32. Fit new valve guides with tool 884549. Use a press.



Removing the nozzle sleeves

33. Insert the expander screw on tool 884541 into the copper sleeve and screw anti-clockwise until the screw has expanded and fastened in the sleeve. Then pull hard so that the threads go into the copper material. Fit the yoke on the stud bolts holding the injector. Screw on the nut and rotate until the sleeve is removed.

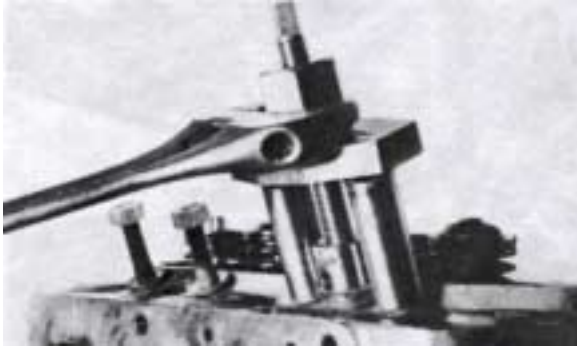

34. Replacing the O-ring which seals between sleeve and cylinder head. Dip the O-ring in soapy water before fitting it. Wash and blow clean before filling the new injector sleeve with tool 884539. Knock in the sleeve until it bottoms. Check to make sure that the O-ring is not damaged or has moved.

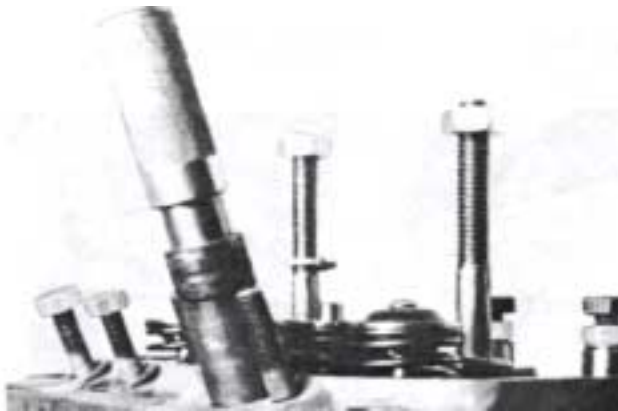

34. a. Oil the spreader tool 884537 and push the tool into the sleeve (ensure that the bolt is screwed back sufficiently). Place nuts or washers on the stud bolts so that the yoke can be securely attached with nuts. Screw the tool down as far as the recess in the injector sleeve allows. Thus pressing out the sleeve. Remove the tool.

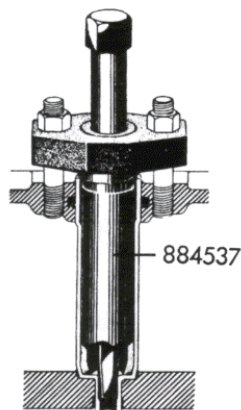

Installing the valves

35. Thoroughly clean the cylinder head, valve guides and valve seats. Use a small brush. Check that the bevel on the seats is correctly ground by applying marking blue to the bevel on the valve disc and rotating it against the seat under light pressure. If the blue is not distributed evenly on the entire bevel surface of the seat (this indicates a leaky valve), grind the valve further and re-check until results are successful. The width of the seat should be approx. 1 mm (0.04"). Oil the valve stems before filling them in their respective guides. **IMPORTANT!** Make sure that the valves and valve springs are re-filled in their original positions. Place the cylinder head on its edge and fit the valve springs and collets 2. Use a valve spring tool. Finally fit the rubber seal 1 (MD6A) on the intake valves.



Checking the cylinder head level finish

36. If there is any doubt as to the level finish of the cylinder head after carrying out repairs, check as follows:

Completely disassemble the cylinder head and clean it thoroughly. Measure with the help of a steel ruler (check the ruler against a flat disc) by placing it on the cylinder head face as shown by the arrows in the diagram below. Then measure with a feeler gauge the gap between the ruler and the face of the cylinder head at the marked measuring points. A maximum gap of 0.00—0.10 mm (0.00—0.004") measured crisscross (see diagram below) and 0.00—0.10 mm (0.00—0.004") measured laterally (see diagram below) is approved. If the measured gap is between 0.10 mm (0.004") and 0.20 mm (0.008"), then the gap must be grinded. If the gap exceeds 0.20 mm (0.008"), replace the cylinder head with a new one.

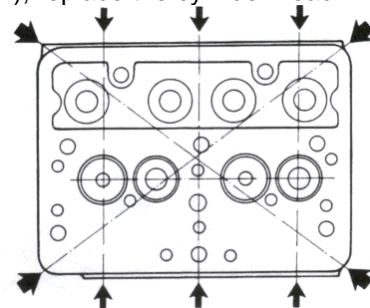

Pressure-testing the injectors

37. Check the spray pattern at an opening pressure of 180 kp/cm^2 (2560 lbf/in^2). Also check that the fuel jets cease simultaneously at all four holes and there is no dripping afterwards.

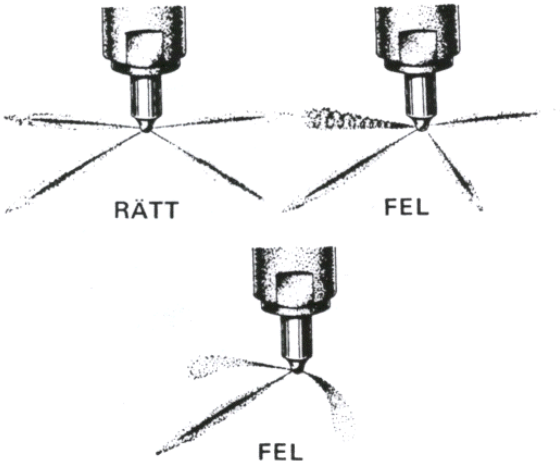

Overhauling the feed pump

39. Exert force on the pump lever (see Fig.). If the pump “squeaks” then it is in good condition. If it does not, the diaphragm must be replaced. This is done as follows:



Adjusting the opening pressure

38. Adjust the opening pressure with adjuster washers 1, which are available in different thicknesses ranging from 1 mm (0.04”) to 1.95 mm (0.08”) at intervals of 0.05 mm (0.002”) between each washer. Screw apart the injector and replace the adjuster washer with a thinner or thicker one depending on whether the pressure has to be reduced or increased. Screw the injector together again and check the opening pressure and spray pattern. Continue this procedure until results are satisfactory.

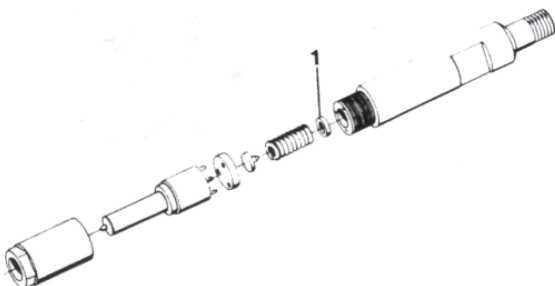

40. Release the cover centre screw, lift out the strainer 1 and clean it.

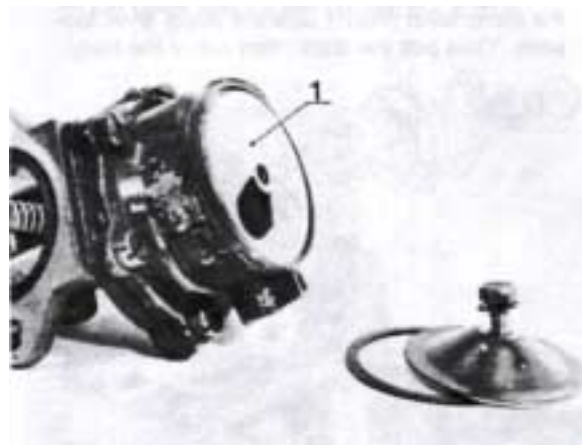

41. Unscrew the six bolts holding the upper and lower sections of the pump body together. Remove the pump lever spring 1, and unscrew the screw 2, which holds the pump lever shaft.

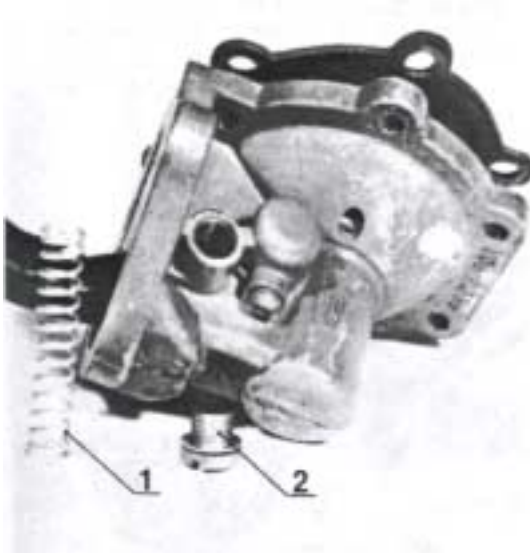

43. Undo the screw 1, and pull out the manual pump lever 2 and replace the spring 3 if in poor condition. NOTE! keep an eye on the rubber seal which is pressed into the body.



42. Press down the diaphragm and shake forwards the pump lever shaft 1 until the pump lever loosens. Then pull the diaphragm out of the body.

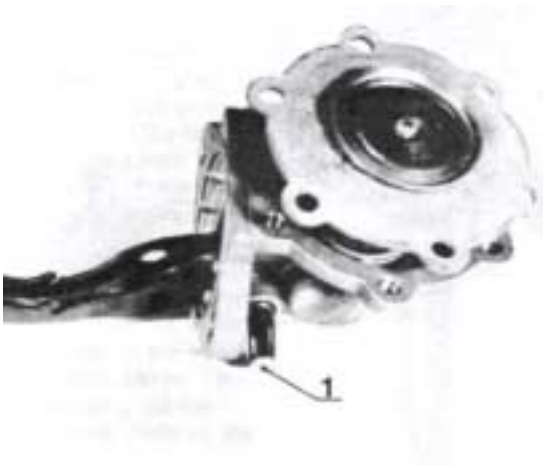

44. Thoroughly clean the pump body and replace worn parts.
Re-fit the manual pump lever. Press the diaphragm in and fit the pump lever onto the diaphragm shaft. Then insert the shaft and tighten it with the screw. IMPORTANT! Do not forget the washer on the screw.
Place the strainer on the upper body section and screw tight the cover and gasket. Assemble the pump body halves and fit the retaining washer 1 for the spring 2 on the mechanical pump lever 3. IMPORTANT! The retaining washer can only be fitted in one way. Fit the spring and then the O-ring 4 which seals against the engine.

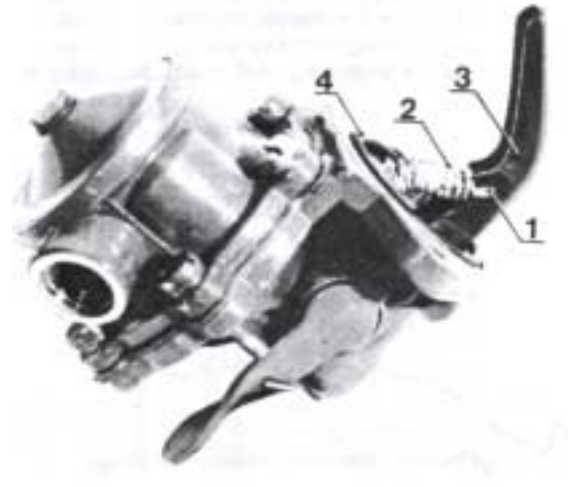

Overhauling the sea-water pump

45. Remove the cover (6 bolts). Replace the impeller with the help of two screwdrivers or similar tools. **IMPORTANT!** Protect the edges on the pump body. See Fig. below. Lever out the impeller with the screwdrivers so far that the bolt becomes visible.

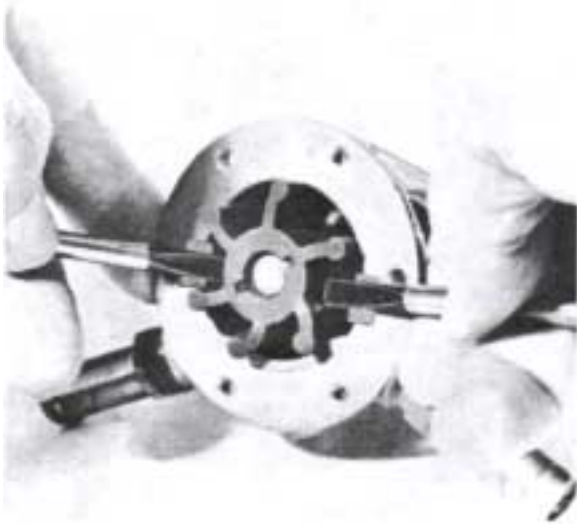

46. Unscrew the bolt and pull the impeller off the shaft. If the sealing rings also have to be replaced, the shaft can be pulled out entirely together with the impeller, after which the bolt can be released.

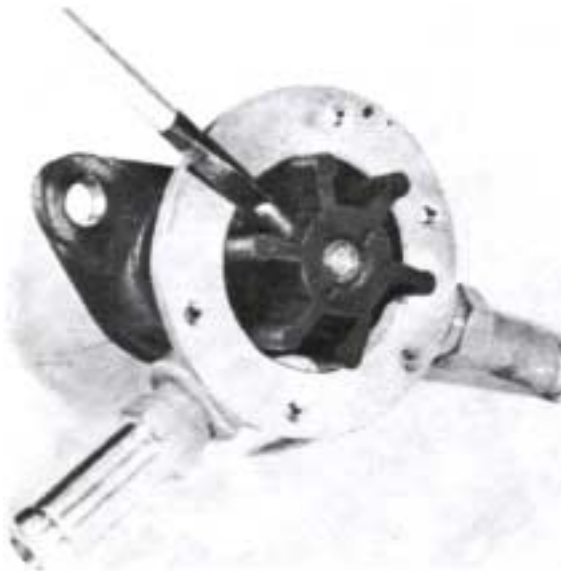

47. Remove the sealing rings 2 and the 0-ring 1 (earlier engines), and clean the pump body and shaft. (**IMPORTANT!** The pump must be removed from the engine.) Check to make sure there is no burr on the shaft. **NOTE!** A new 0-ring must not be fitted.

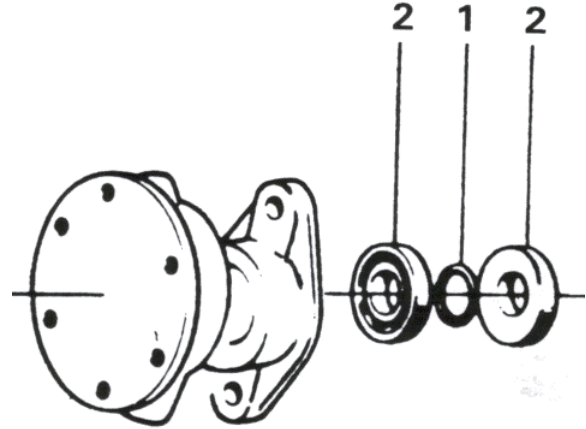

48. Fit new sealing rings. **IMPORTANT!** Turn the sealing rings so that they are in their proper position and make sure that they do not block the drain hole in the pump body. Grease the shaft and carefully fit it into the body. Screw it through the sealing rings but make sure the rings are not damaged when doing so. Place the shaft so far into the housing that the bolt hole is outside: Fit the impeller and screw in the bolt. Then carefully push in the impeller until it bottoms. Place a new gasket on the cover and tighten up with the 6 bolts.

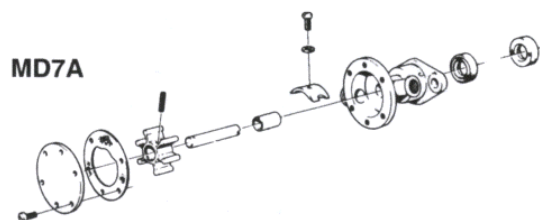
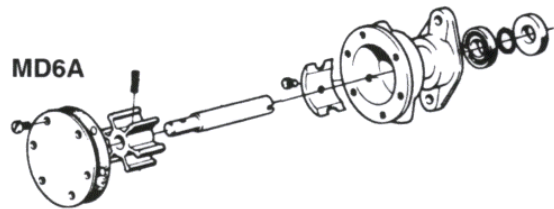

Checking the thermostat

49. Lower the thermostat into hot water and with a thermometer test to see whether the thermostat opens and closes at the right temperature. It should start opening at 60°C (140°F) and be fully open at 74°C (165°F). If the thermostat is faulty, it must be replaced. Clean and fit a new rubber gasket 1 on the thermostat. Place a new O-ring 2 for the water hole on the lower edge of the thermostat housing and fit the housing on the exhaust manifold.



INSTALLING THE ENGINE

50. Before installing, heat the crankshaft drive gear. Place the key in the key slot on the crankshaft and press on the new drive gear. Fit new bearing shells. Oil the bearings. Install the crankshaft. Fit an axial bearing half 1 on each side of the intermediate main bearing with the oil grooves 2 facing outwards.

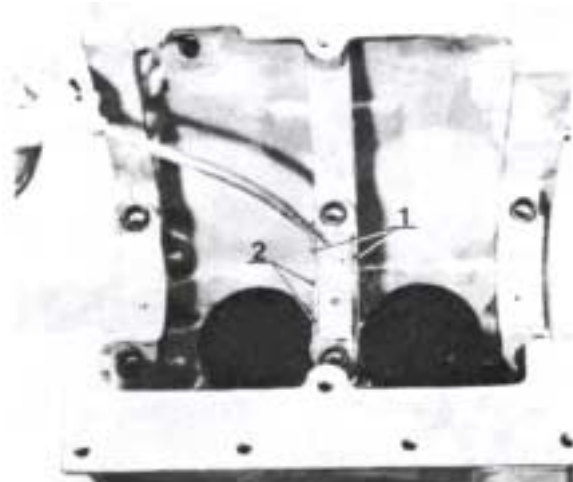

51. Oil and fit the bearing halves in the caps. Place the caps according to the marking on the block. Fit the remaining axial bearing halves on the intermediate cap with the oil grooves facing outwards. NOTE! Fit a new O-ring on the rear cap which is integrally built with the lubricating oil pump. The tightening torque for the main bearings is 50 Nm (5 kpm = 36 lbfft). Turn the engine.

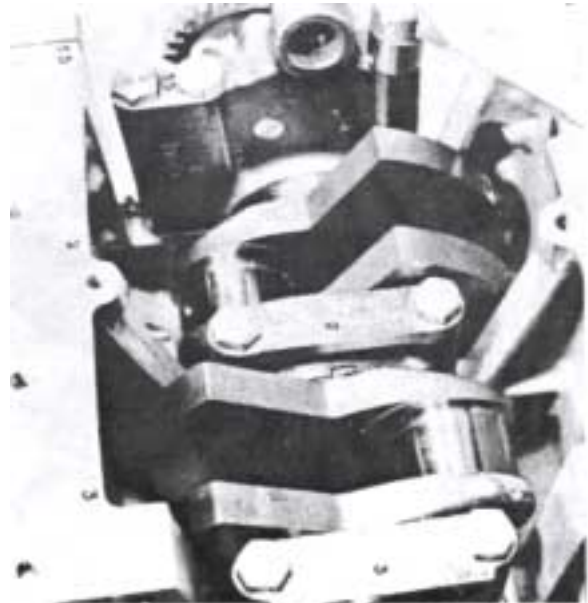

52. Turn the piston rings so that their respective gaps are apart from each other. The piston top is marked with "Front" and should point towards the flywheel. NOTE! Fit the connecting rod which is marked with punch pops nearest the flywheel. Carefully tap the piston downwards through the installation tool with a wooden handle or similar. Place the engine on its side and tighten up the caps. Tightening torque = 50 Nm (5 kpm = 36 lbfft). Lock the bolts with the lock washers.

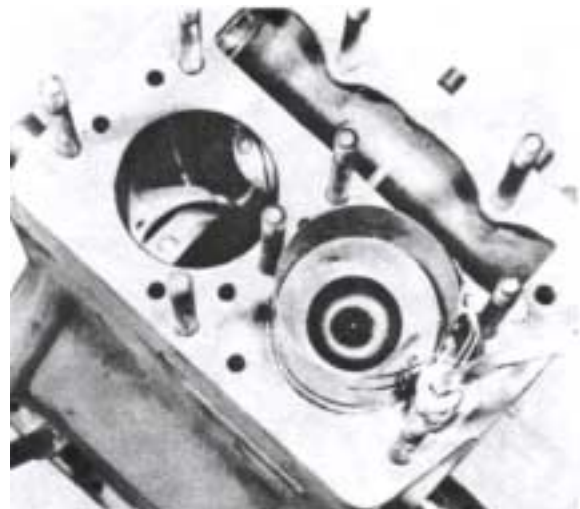

53. Fit the "protective cover" for the starting crank. Replace the sealing ring and gasket.



55. Fit a new gasket and install the timing gear casing (4 bolts). Tap carefully so as not to deform the guide pins.

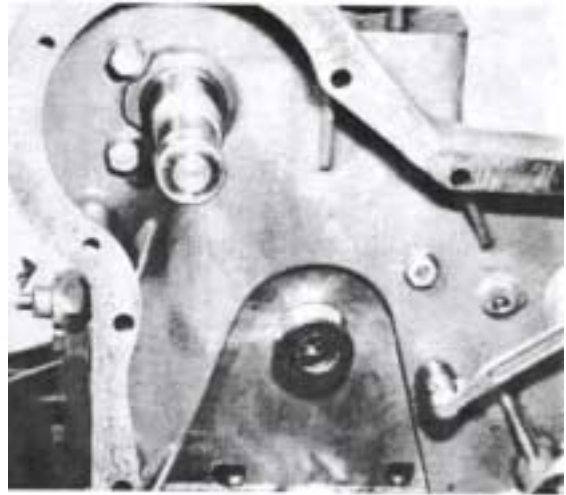

54. Fit the camshaft. Observe due care so that the sealing ring in the protective cover for the starting crank is not damaged. Knock the starting crank pin into the camshaft. Use a tube or similar as a counterhold.

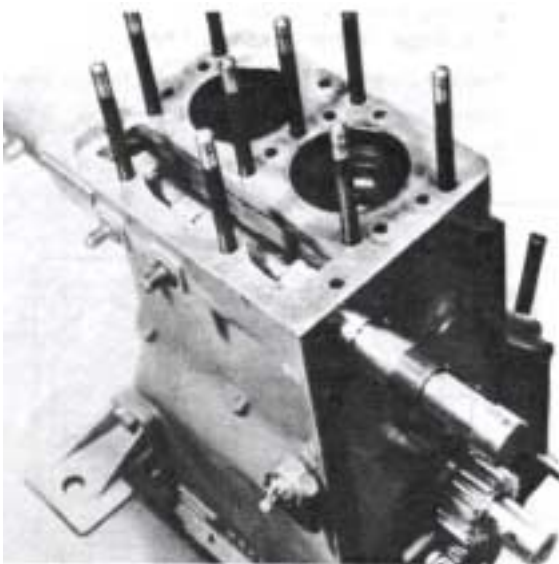

56. Fit the key in the camshaft and then the gear wheel. Turn the gear wheel so that the figure which is punched on the ring gear faces outwards. Fit the star washer and the nut on the camshaft. Tighten up later on (see Point 59). When a new engine block is used, a new shaft pin 1 for the intermediate gear must be fitted.

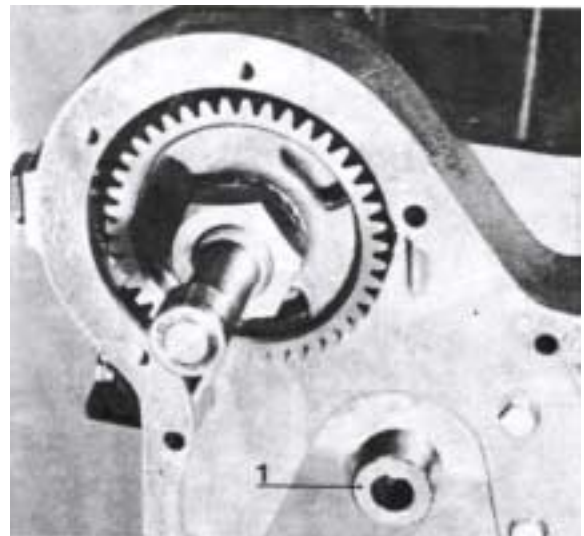

57. Fit the intermediate gear. Check that the punched-in figures on the crankshaft drive and camshaft gear wheel coincide with the marking on the intermediate gear.



58. Place the large flat washer on the intermediate gear with the bevel facing outwards, and thereafter the steel-rubber washer 1. Tighten with the bolt. NOTE! On earlier engines a plastic washer is used. This must be scrapped and replaced by the steel-rubber one.

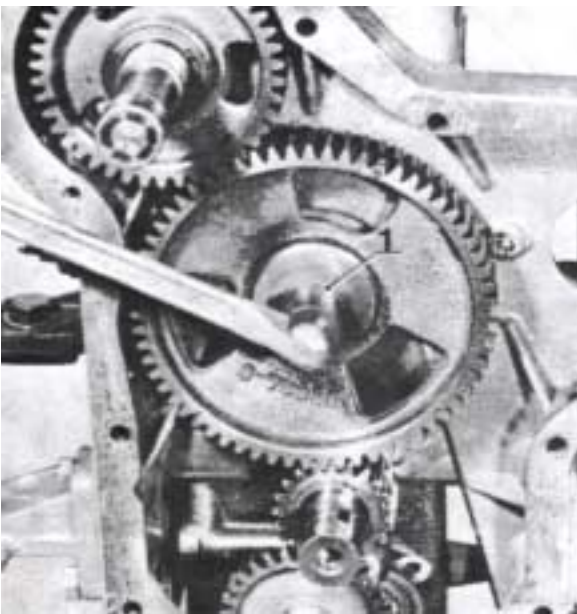

59. Install the fuel injection pump. Use a new gasket. Fit the key on the pump shaft and install the gear wheel. IMPORTANT! The figure must face towards the figure on the intermediate gear. Tighten up the gear wheel with the nut which also functions as a flange for the water pump. Tightening torque = 60 Nm (6 kpm = 43 lbfft). Use a counterhold. Tighten the camshaft nut. Remove the counterhold.

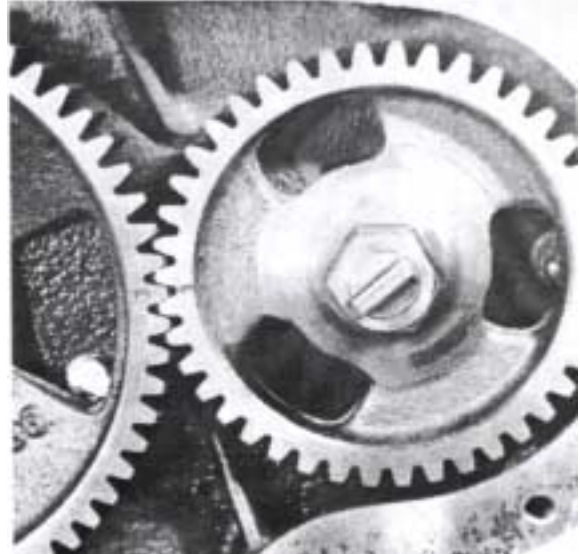

60. Fit the cylinder head gasket. It can only be fitted in one way. If the stud bolts in the cylinder head must be replaced, fit the new ones to a torque of 20 Nm (2 kpm = 14 lbffi). Fit the cylinder head. All the nuts must have washers under them except the one on which the lift eyelet is filled. Tightening torque = 70 Nm (7 kpm = 50 lbm).

NOTE! Tightening is in three stages.

First stage: 10 Nm (1 kpm = 7 lbm)
 Second stage: 40 Nm (4 kpm = 29 lbffi)
 Third stage: 70 Nm (7 kpm = 50 lbm).

See tightening scheme below.

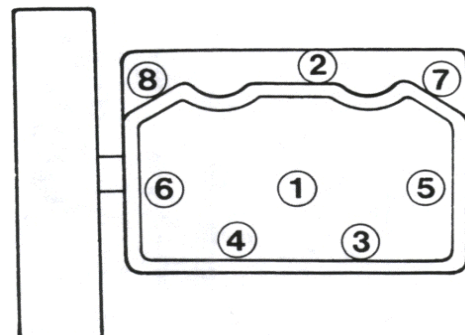

61. Place a new gasket on the inner timing gear cover and fit the outer timing gear casing. Two short bolts are fitted at the bottom. Trim off any part of the gasket which sticks out.

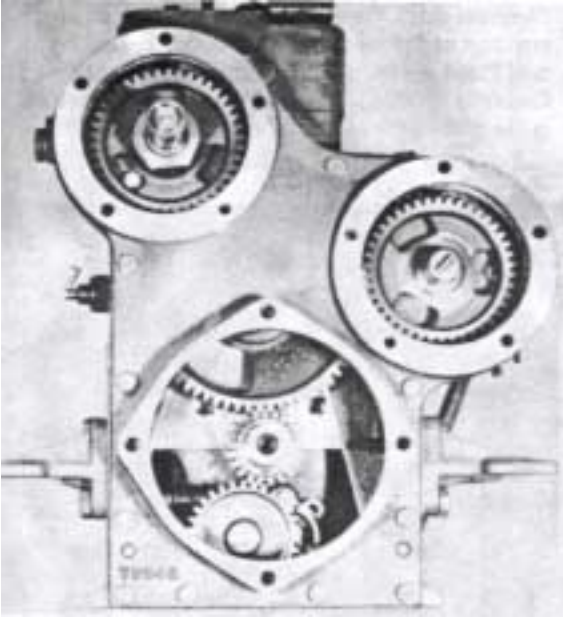

63. Place a new gasket on the water pump and fit it with the two bolts. Make sure that the groove in the pump shaft engages in the flange nut.

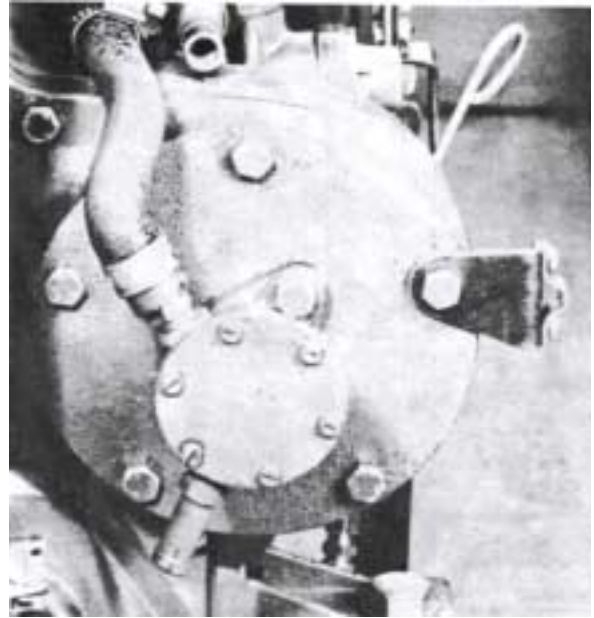

62. Fit a new gasket and cover where the water pump is to be installed. NOTE! The control bracket is fitted with one of the bolts. Two bolts are shorter.

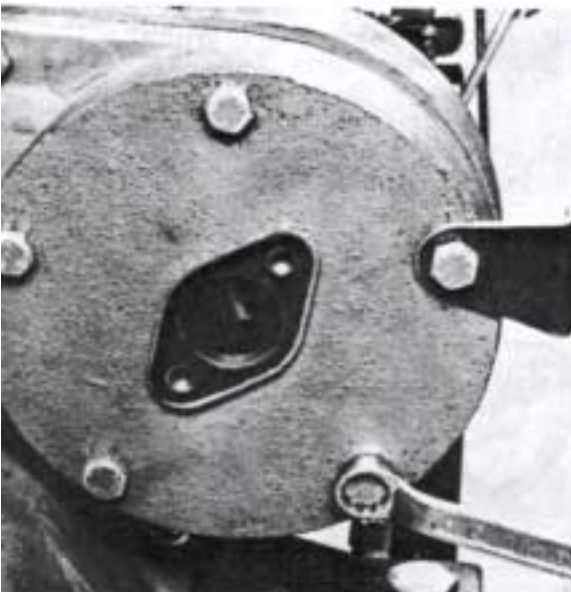

64. Fit the cover with new gasket over the camshaft end. NOTE! The bolts have three different lengths. The Fig. below shows where they are placed.

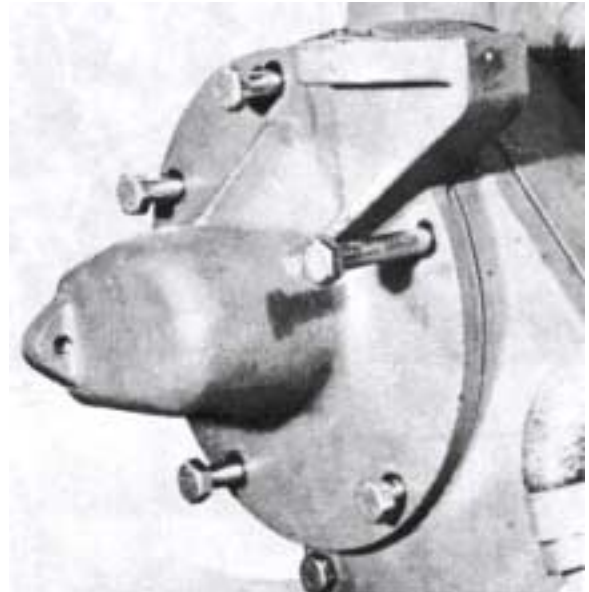

65. Install the fuel pump. Make sure that the 0-ring is in position. Use a new 0-ring. The pump is installed with two inhex bolts and spring washers. Check that the pump "squeaks" by pressing in the pump lever before installing the pump on the engine. Connect up the fuel hoses.



67. Fit the oil sump together with a new gasket. The gasket can only be fitted in one way. Begin with the four corner bolts for locating the sump into position. Tighten all the bolts thoroughly. Remove the sealing ring on the casing for the crankshaft (flywheel side). Fit a new sealing ring. Trim off any part of the oil sump gasket that is sticking out. Place a new gasket on the cover and fit it. Carefully knock on the cover until it fits over the guide pins. Tighten up the cover with the bolts.

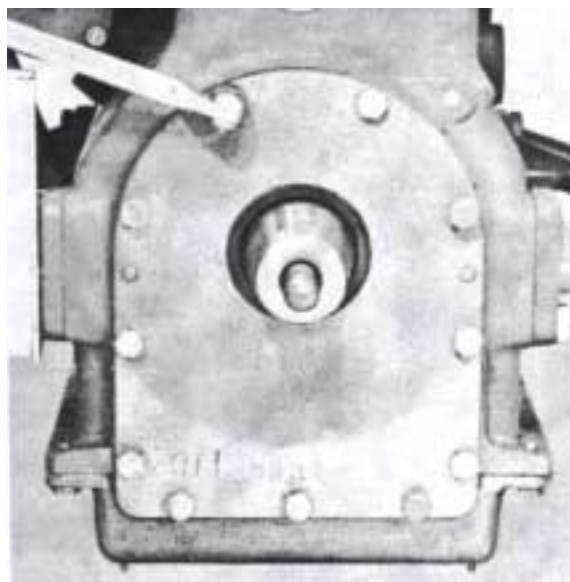

66. Release the lock wire securing the lubricating oil strainer. Lift out the strainer, wash it and blow it dry with compressed air. Re-fit it and lock it with the lock wire. Turn the engine and fit the complete oil strainer.

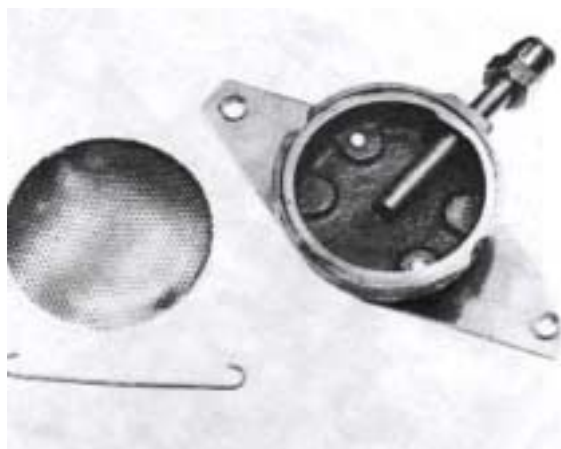

68. Fit the rocker arm, fuel filter and fuel lines. NOTE! Replace the fine filter insert (see page 25, Point B) by turning the hex head in the bottom of the container. When the installation of the engine is completed, bleed the fuel system through the bleeder screw 1. See more detailed instructions about this on page 25, Point B.



69. Fit the key for the flywheel and push on the flywheel. Fit the thick washer and tighten up the flywheel with the nut. Tightening torque = 180 Nm (18 kpm = 130 lbfft). Use a counterhold through the flywheel.

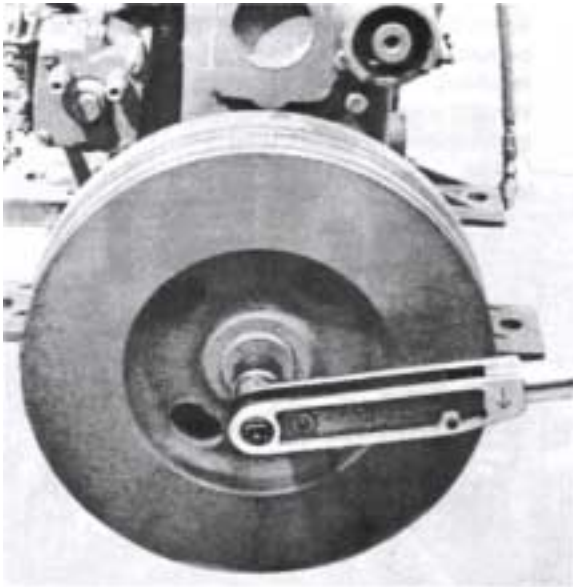

71. **MD6A.** Install the stars generator with its bracket. Screw tight the tensioning bar to the engine. Earlier engines have a washer placed between the engine and bracket.
MD7A. Install the alternator with its bracket. Screw tight the tensioning bar to the engine.

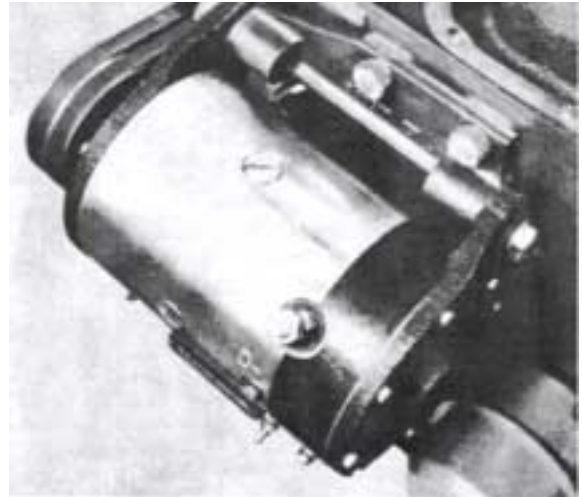

70. Oil the oil filter rubber gasket. Fit the oil filter and the oil pressure contact. Screw in the oil filter so far that the rubber gasket just touches the engine. Then screw tight a further half turn. **IMPORTANT!** Screw by hand.

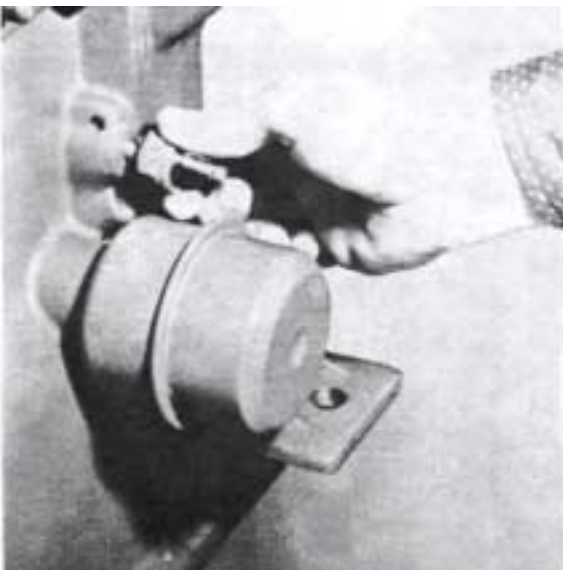

72. Install the exhaust manifold. Fit a new gasket. Check to make sure that the rubber hose for the cooling water is in good condition. Fit the cooling water hose from the cooling water pump and tighten up the hose clamp.

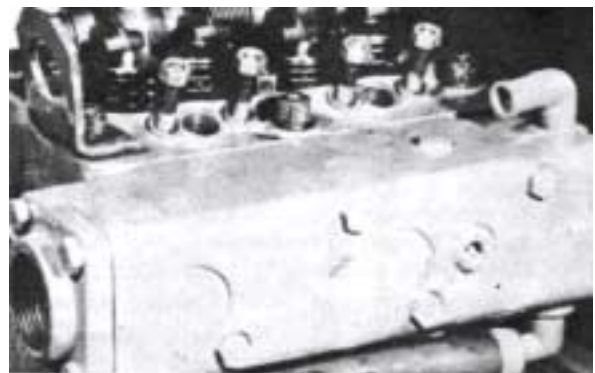

73. Fit the injectors and the overflow pipe.
Tightening torque for injectors' nuts 1 = 8 Nm (0,8 kpm = 5,8 lbfft). NOTE! Do not forget the new sealing washers 2 on both sides of the overflow pipe.

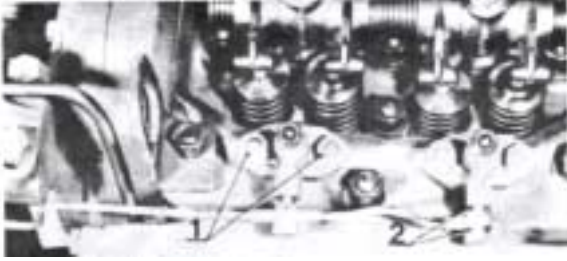

74. Fit the fuel pipes between the injection pump and the injectors. NOTE! Check to make sure that the brake pipes are properly installed, see Fig.

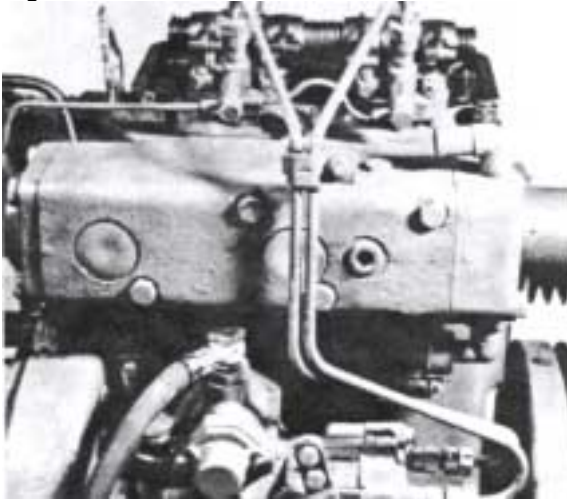

75. Adjusting the BOSCH injection pump

- Turn over the engine until the valves in cylinder No. 2 "rock". Continue to turn over the engine in the normal direction of rotation until marking 10 on flywheel coincides with the marking on the block.
- Remove the pump inspection cover and check that the marking (1) coincides exactly with the pointer (2). Adjustments are made by slackening the pump securing nuts and turning the pump.
- Tighten the nuts.
- Check the setting by turning over the engine 1/4 turn in the opposite direction of rotation, then back again to the "10," marking on the flywheel. Check that the marking (1) and the pointer (2) still coincide.
- Fit the inspection cover with the rubber gasket.



75a. Adjusting the CAV fuel injection pump

- Rotate the flywheel in a clockwise direction until both the valves on No. 1 cylinder are closed (compression stroke).
- Assemble the pump so that the marking coincides with that on the transmission housing see fig.
- Fit on the gear wheel. NOTE! The figure (1) is to be turned towards the figure (1) of the intermediate wheel.
- Bleed the air from the pump with the bleed-screws in the following order 1, 2, 3.

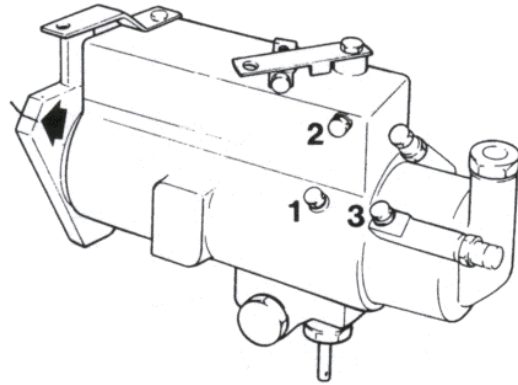

76. Adjust the valves as follows:
Rotate the flywheel until both valves on a cylinder "rock". Turn the flywheel one further turn and adjust the valves for this cylinder. Repeat the procedure for the other cylinder. With a hot engine, the clearance should be 0.30 mm (0.012") for both the intake and exhaust valves.

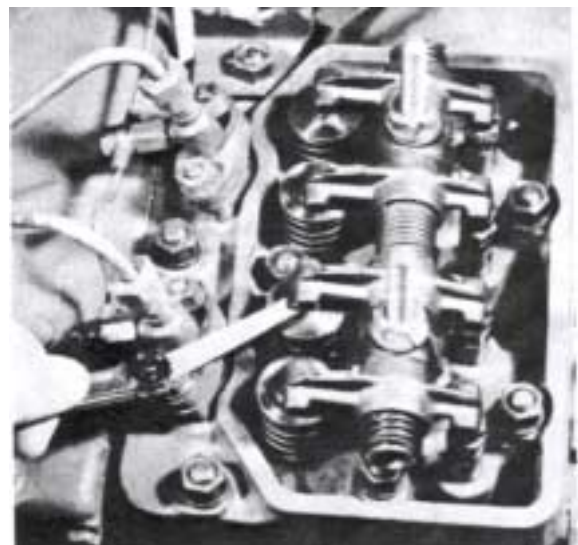

77. Oil the rocker arm and fit the rocker arm cover together with new gaskets. Fit the intake manifold and gasket and install the air cleaner. Fit the ventilation hose between the rocker arm cover and air cleaner.
NOTE! Fit the intake manifold with the flange displaced towards the reverse gear side in order to provide space for the air cleaner.

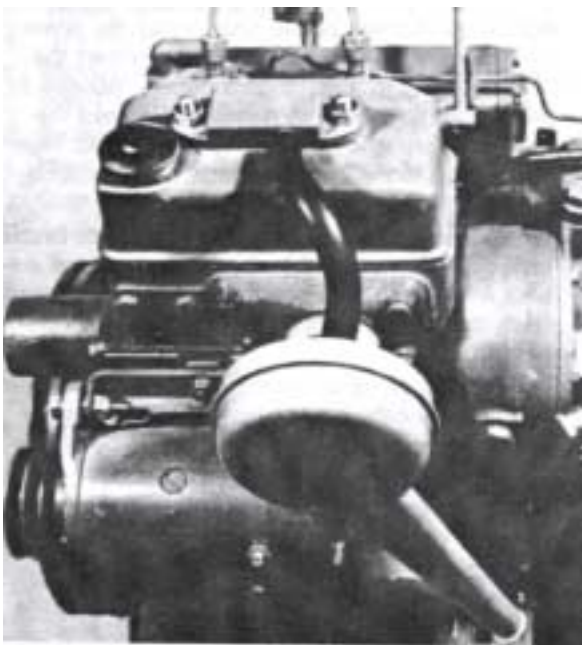

79. Fit the key in the crankshaft. Heat the flange and fit it on the shaft. Tighten it up with the bolt and the thick washer. Tightening torque: 80 Nm (8 kpm = 57 lbfft). Bend down the thin washer over the bolt head. Fit the rubber damper.



78. Fit the V-belts and tension the alternator. The belts are properly tensioned when they can be depressed under normal thumb pressure about 3 - 4 mm (1/8"). Depress between the start-generator and flywheel.

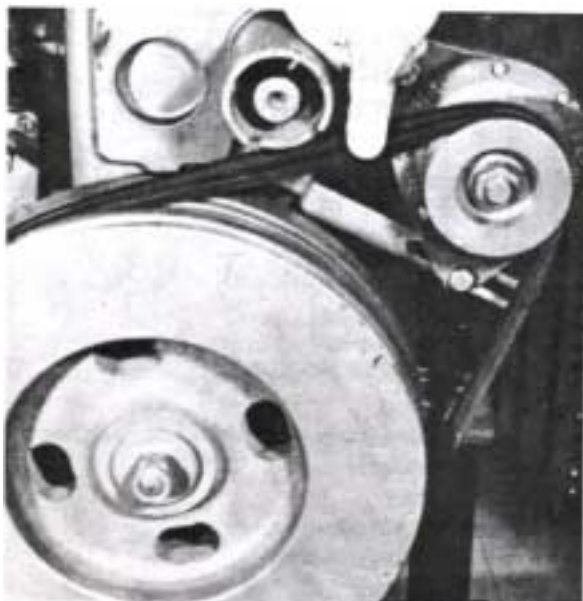

80. Install the reverse gear and gasket and connect up the cooling water hose between the reverse gear and water pump. Then fit the exhaust elbow.

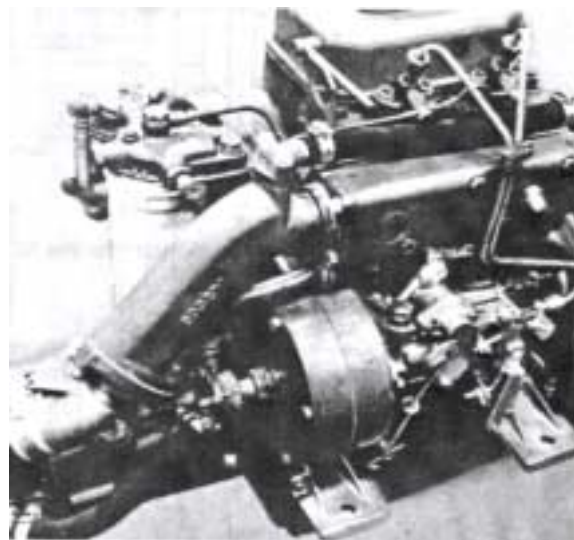

81. Fill the engine and reverse gear with oil. Concerning the oil quantity and quality, see under "Technical Data".

Electrical system

ELECTRICAL SYSTEM

IMPORTANT

82. The following applies to engines fitted with alternators:

1. **Never break the current between the alternator and battery while the engine is running. If a main switch is fitted, it must not be switched off until the engine has stopped.** Otherwise no cable must be disconnected while the engine is running, since this also can ruin the charging regulator.
2. Check regularly the battery, battery cables and cable terminals. The battery poles should be well-cleaned and the cable terminals always well-tightened and well-greased to ensure continuous function. All cables in general must be well-tightened, there must be no loose connections. Note! On no account must the battery's positive and negative poles be mixed up when the battery is fitted.

3. When starting with the help of a helper battery, first check that the helper battery has the same rated current as the standard one. Connect the helper battery to the standard battery, positive to positive and negative to negative. Remove the helper battery when the engine has started. Note! The cables to the standard battery must not be broken.
4. With electrical welding on the engine or installation components, the charging regulator cables must first be disconnected and insulated. Both the battery cables must also be disconnected.
5. In the event of repairs to the alternator equipment, both battery cables must first be disconnected. The same applies if the battery has to be rapidly charged.
6. Never test any of the components with a screwdriver, etc. against a terminal to see if it sparks.

Wiring diagrams:

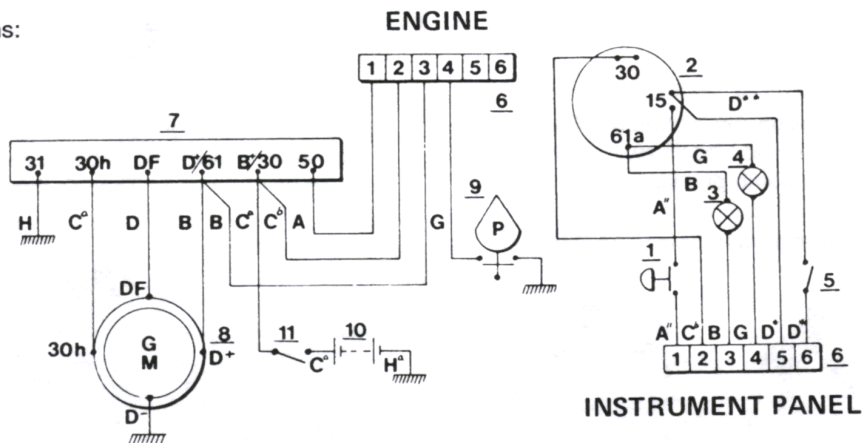

Fig. 82 Wiring diagram for the MD6A with start-generator (no rev counter and temp. gauge)

Cable Marking

Des.	Colour	mm ²	AWT
A"	Beige	2.5	13
B BI	Black	1.5	15
C	Red	25	3
C	Red	2.5	13
D	Green	1.5	15
D	Green	2.5	13
G	Brown	1.5	15
H	Blue	1.5	15
H	Blue	25	3

1. Starter button

2. Key switch

3. Charging warning light

4. Control light for oil pressure

5. Switch

6. Terminal board, instrument panel resp. engines

7. Charging regulator

8. Start-generator

9. Oil pressure indicator

10. Battery 12V, max. 60 Ah

11. Main Switch

Fig. 83. Wiring diagram for late prod. Type MD6A

1. Key switch
2. Instrument panel switch
3. Temperature gauge
4. Warning light for "low oil pressure"
5. Rev counter
6. Warning light, charging start-generator
7. Switch, optional equipment
8. Terminal board
9. Warning light, charging alternator (Optional Equipment)
10. Battery
11. Main switch
12. Start-generator
13. Alternator (Optional Equipment)
14. Charging regulator
15. Fuse
16. Temperature sender
17. Rev counter
18. Oil pressure sender
19. Other electrical equipment

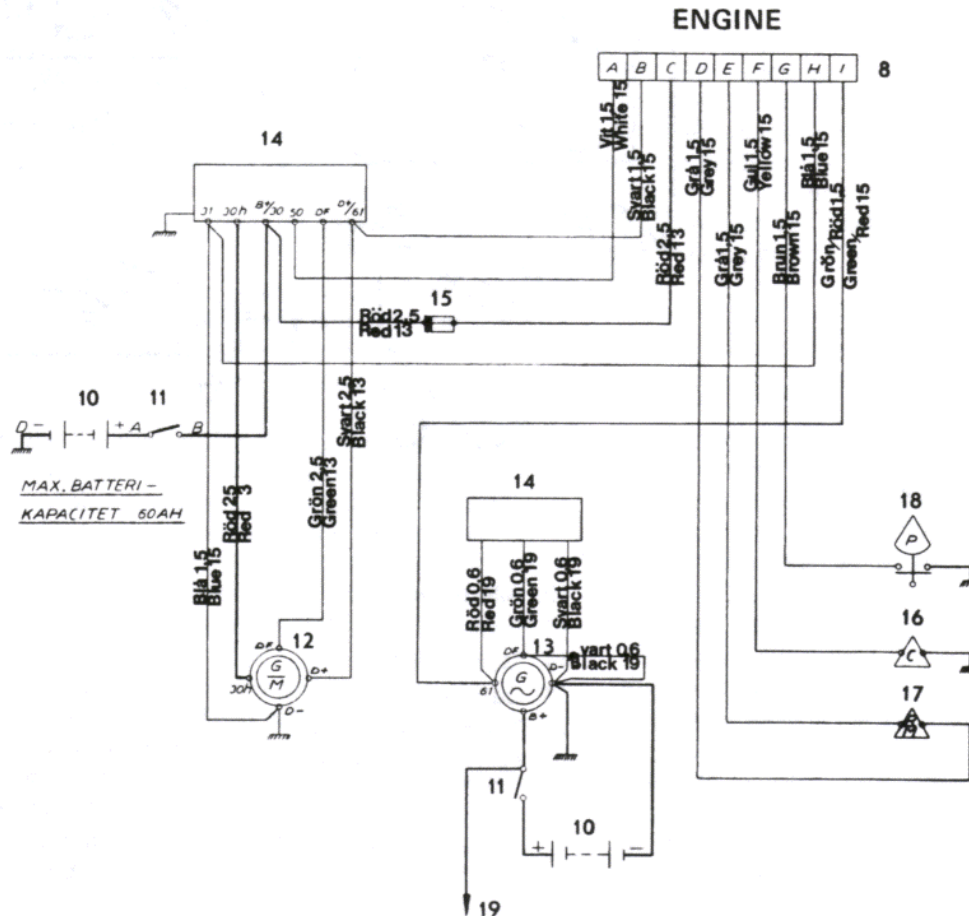
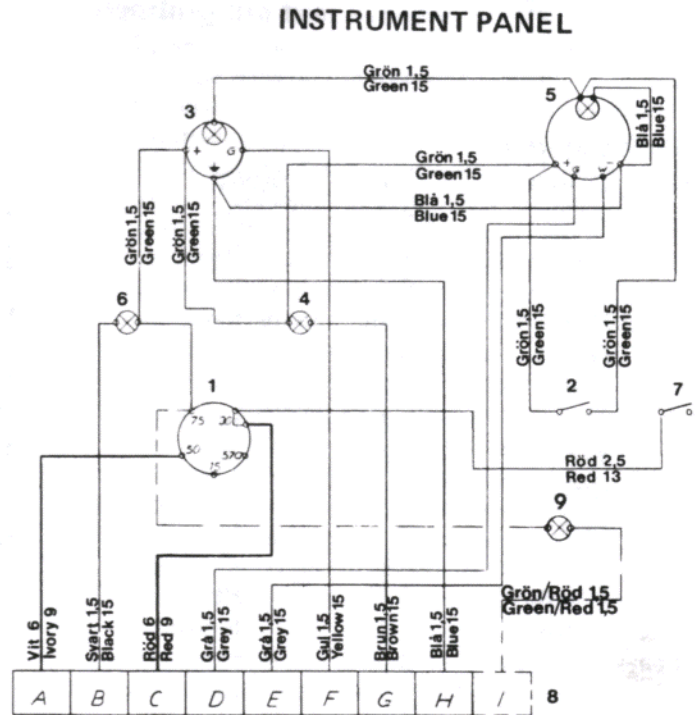

Wiring Diagram MD7A

CABLE MARKING

Des.	Colour	mm ²	AWG
A	White	6	9
B	Black	1.5	15
B'	Black	0.6	19
B''	Black	0.75	18
C	Red	6	9
C'	Red	35	1
C''	Red	0.6	19
F	Yellow	1.5	15
G	Brown	1.5	15
H	Blue	4	11
H'	Blue	35	1
I'	Green/red	0.75	18
J	Green	1.5	15
J'	Green	0.6	18
J''	Green	0.75	18
K	Blue/yellow	0.75	18
L	White/red	0.75	18
M	Blue/red	0.75	18

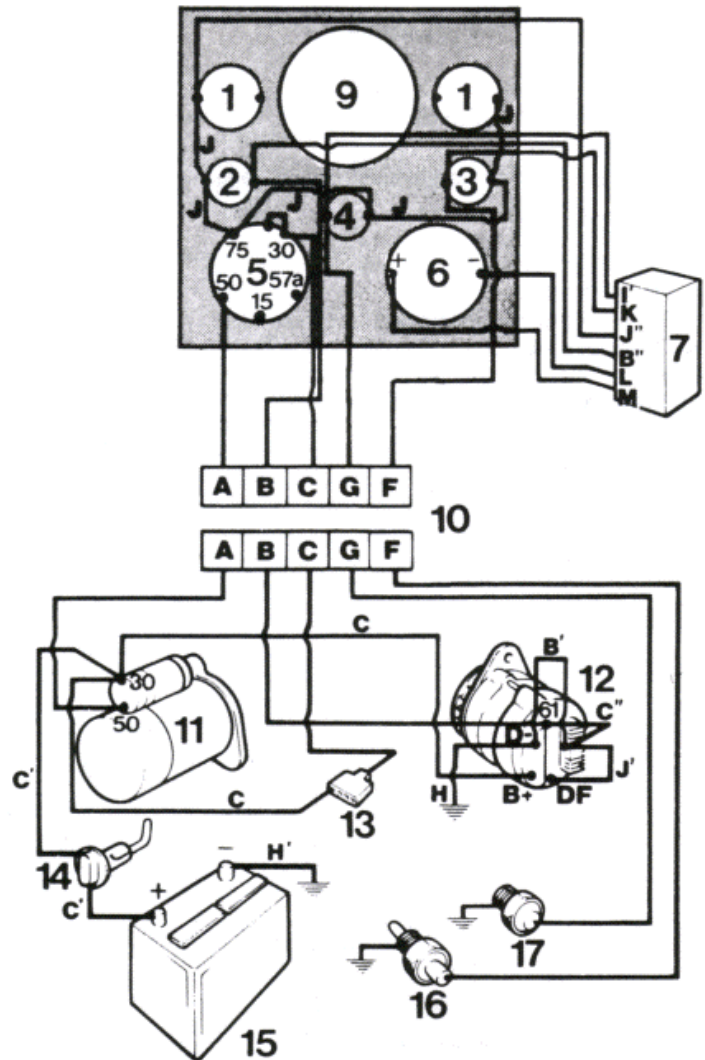

Position List

- 2. Charging warning light
- 3. Warning light for "high temperature"
- 4. Warning light for "low oil pressure"
- 5. Key switch
- 6. Siren
- 7. Alarm unit
- 9. Place for instrument, extra equipment
- 10. Terminal board
- 11. Starter motor

- 12. Alternator
- 13. Fuse
- 14. Main switch
- 15. Battery
- 16. Temperature sender
- 17. Oil pressure sender

FAULT TRACING

The fault-tracing scheme below includes only those faults which arise most often during operation.

Fault-tracing scheme

Engine does not start	Engine stops	Engine does not reach right operating speed at full throttle	Engine runs unevenly or vibrates abnormally	Engine becomes abnormally hot	FAULT	Notes
X					Main switch not on, flat battery, broken electric cables	A
X	X				Empty fuel tank, closed fuel cock, blocked fuel filter	B
X	X		X		Water, air or impurities in fuel	B
X	X	X	X		Defective injectors	C
		X			Boat abnormally loaded. Growth on boat bottom.	D
		X	X		Damaged propeller	E
				X	Clogging of cooling water intake, cooling jackets, defective impeller or thermostat	F







- A. Check the state of charge of the battery with the help of a hydrometer which shows the specific gravity of the battery acid. This will vary with the state of charge, see under "Technical Data". Also see under "Electrical system" on page 23.
- B. Replace the fine filter by turning the hex head in the bottom of the container. The fine filter and container are of the throw-away type. They must be discarded and a new one installed. Check that the contact surface for the cover is absolutely clean and that the filter gasket is in good condition. Screw on the new filter tight by hand until the gasket goes against the cover. Then tighten the filter a further 1/2 turn. The bottom of the filter container has a drain plug for draining water and impurities that have accumulated in the fuel. Bleed the fuel system after draining and replacing the filter, also check for leakage. Remove the feed pump cover and clean the pre-filter in the fuel oil. Then fit the filter with the pins facing upwards and place the gasket (undamaged) in position and tighten up the cover. Bleed the fuel system. Check and if necessary drain the extra fuel filter if such is fitted. Look out for fuel splash.

Bleeding the fuel system

To ensure that the engine starts, the fuel system must be bled on the following occasions: 1) When changing the fine filter. 2) When draining through the drain plug. 3) When cleaning the pre-filter. 4) When running the fuel tank empty. 5) When installing the fuel injection pump. 6) With leakage and when working on the fuel line. 7) When the engine has been stopped for a long time. Bleeding is as follows: Open the bleeder screw 1 on the fine filter. See Point 68. Pump forward the fuel with the help of a hand primer until about 0.2 litre (0.2 qt.) fuel has run out. Close the bleeder screw. If you get poor pumping effect, turn over the engine a bit so that the pump drive cam alters its position. If the fuel injection pump has been removed, or when starting an entirely new engine for the first time, the fuel injection pump must be bled. Pump with the hand primer for about 1/2 minute. This automatically bleeds the fuel injection pump. Slacken the delivery pipe nuts for the injectors and turn over the engine with the start-generator until fuel comes from the delivery pipes. Tighten up the delivery pipe nuts and start the engine.

- C. Check the injectors with regard to their opening pressure, tightness and spray pattern. Max. running time of 400 operating hours or once a season is recommended between these checks. See also Points 37 and 38.
- D. In order to get the best possible operating economy, the engine speed selected should be minimum 300 rev/mm below the max. speed for The engine during lengthy periods of operation. When the boat has been in the water for so' time, the max. speed for the engine can drop due to growth on the outside of the hull. Use anti-fouling paint. Check and clean the hull regularly.
- E. Check the propeller blades. If a propeller blade is damaged, the propeller must be replaced. A propeller blade can also be warped, something which is very difficult to discover. Place the propeller on a flat disc and measure the blades. If a propeller blade is warped, the propeller should be replaced.
- F. Check the cooling system for leakage, clogging, etc. Check to make sure the thermostat opens at the right temperature. The thermostat can be removed after having taken down the thermostat housing at the front of the exhaust manifold. See also Point 49. The pump body in the sea-water pump is made of neoprene rubber, which can be damaged with shortage of water, e.g., in the event the sea-water inlet is blocked. Proceed according to Points 45-48 in the event the impeller and sealing rings have to be replaced. NOTE! If the boat is in the water, the bottom cock must be closed before the sea-water pump is removed. But do not forget to open the cock again.

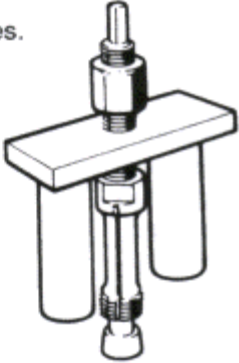
Special Tools

Part No.	Description
884537	Flaring tool for copper sleeve 
884538	Drift for pressing out valve guides. 
884549	Drift for pressing in valve guides. 
884539	Drift for pressing in nozzle sleeves. 
884541	Tool for removing nozzle sleeves. 
884535	Nipple for compression gauge. 
884543	Yoke for installing nipple. 

Technical Data

Technical Data MD6A

General

Type designation	MD6A
Output (DIN) at 40 rev/sec (2400 rev/mm)	7.4 kW (10 h.p.)
Number of cylinders	2
Bore	70 mm (2.7560")
Stroke	82 mm (3.2283")
Capacity	0.63dm ³
Compression ratio	18.7:1
Compression pressure at starter motor speed	23—25 kp/cm ² (327—355 lbf/in ²) ¹⁾
Direction of rotation, viewed towards flywheel	Clockwise
Idling speed	12 rev/sec (700 rev/min)
Oil pressure, hot engine	4 kp/cm ² (57 lbf/in ²)
Oil pressure, idling, hot engine	0,8 kp/cm ² (11 lbf/in ²)

Cylinders

Material	Cast iron
Bore, standard	70.000—70.019 mm (2.7560—2.7566")
0.500 mm (0.020") oversize	70.500—70.519 mm (2.7755—2.7763")

Pistons

Material	Light-metal
Height, total	81 mm (3.19")
Height from gudgeon pin centre to piston crown	51 mm (2.00")
Piston clearance in cylinder	0.086—0.130 mm (0.0034—0.0051")
Pistons, standard	69.889—69.914 mm (2.7515—2.7525")
0.500 mm (0.020") oversize	70.389—70.414 mm (2.7712—2.7722")

Gudgeon pins

Diameter	27.9975—28.0025 mm (1.1023—1.1025")
Gudgeon pin bushing, diameter	28.0125—28.0225 mm (1.1029—1.1032")
Clearance, gudgeon pin — bushing	0.010—0.025 mm (0.0004—0.0010")

Piston rings

Compression rings, number	2
Oil scraper ring, number	1
Upper compression ring has chromium lining	
Piston rings are available for standard size and 0.500 mm (0.020") oversize	
Piston ring clearance in groove, axially:	
Upper compression ring	0.062—0.113 mm (0.0024—0.0044")
Lower compression ring	0.037—0.087 mm (0.0015—0.0034")
Oil scraper ring	0.037—0.089 mm (0.0015—0.0035")
Piston ring gap in cylinder:	
Upper compression ring	0.279—0.406 mm (0.0110—0.0160")
Lower compression ring	0.203—0.330 mm (0.0080—0.0130")
Oil scraper ring	0.350—0.480 mm (0.0140—0.0189")

Crankshaft

Material	Nodular iron
Crankshaft axial clearance	0.08—0.31 mm (0.0031—0.0122")
Main bearing radial clearance	0.026—0.075 mm (0.0010—0.0030")
Connecting rod radial clearance	0.026—0.075 mm (0.0010—0.0030")

¹⁾Measured with Moto Meter nipple 884535 and yoke 884543.

Main bearing journals

Diameter, standard	49.984—50.000 mm (1.9679—1.9685")
0.300 mm undersize	49.684—49.700 mm (1.9560—1.9567")
0.600 mm undersize	49.384—49.400 mm (1.9442—1.9449")

Main bearing shells

Thickness, standard	1.730—1.737 mm (0.0681—0.0684")
0.300 mm oversize	2.030—2.037 mm (0.0800—0.0802")
0.600 mm oversize	2.330—2.337 mm (0.0917—0.0920")

Connecting rod journals

Diameter, standard	49.984—50.000 mm (1.9679—1.9685")
0.300 mm undersize	49.684—49.700 mm (1.9560—1.9567")
0.600 mm undersize	49.384—49.400 mm (1.9442—1.9449")

Connecting rod shells

Thickness, standard	1.730—1.737 mm (0.0681—0.0684")
0.300 mm oversize	2.030—2.037 mm (0.0800—0.0802")
0.600 mm oversize	2.330—2.337 mm (0.0917—0.0920")

Connecting rods

End play at crankshaft	0.25—0.50 mm (0.0100—0.0200")
------------------------	-------------------------------

Camshaft

End play	0.160—0.300 mm (0.0063—0.0118")
Radial clearance in bearing	0.017—0.083 mm (0.0007—0.0033")
Camshaft diameter	43.992—44.008 mm (1.7320—1.7326")
Lift height of cams	5.48—5.52 mm (0.2157—0.2173")
Bushing, diameter	44.025—44.075 mm (1.7333—1.7352")

Cylinder head

Material	Special-alloy cast iron
----------	-------------------------

Intake valves

Disc diameter	28.8—29.0 mm (1.1338—1.1417")
Stem diameter	7.938—7.960 mm (0.3125—0.3134")
Valve seat angle	29.25—29.50°
Cylinder head seat angle	30°
Width of seat in cylinder head	approx. 1 mm (0.040")
Clearance, hot engine	0.30 mm (0.012")

Exhaust valves

Disc diameter	26.3—26.5 mm (1.0354—1.0433")
Stem diameter	7.938—7.960 mm (0.3125—0.3133")
Valve seat angle	29.25—29.50°
Cylinder head seat angle	30°
Width of seat in cylinder head	approx. 1 mm (0.040")
Clearance, hot engine	0.30 mm (0.012")

Valve guides

Length, intake valve	43 mm (1.6930")
Length, exhaust valve	49 mm (1.9291")
Bore	8.000—8.022 mm (0.3150—0.3158")
Height above cylinder head spring face	10.7—11.0 mm (0.4212—0.4331")
Clearance, valve stemguide	0.040—0.084 mm (0.0016—0.0033")

Valve springs

Length, off-load	47 mm (1.8504")
Loaded with 150 N (15 kp = 33 lbf.)	30 mm (1.1811")
Loaded with 230 N (23 kp = 50 lbf.)	21 mm (0.8268")

Lubricating system**Engine**

Oil capacity excl. filter	2.8 litres (2.5 Imp.qts. = 2.9 US qts.)
Oil capacity incl. filter	3.0 litres (2.6 Imp.qts. = 3.2 US qts.)
Oil quality acc. to API-system	CD (DS)
Viscosity, above +10°C (50°F)	SAE 30
Viscosity, below +10°C (50°F)	SAE 20W
Oil pressure, hot engine, idling speed	0.8—1.5 kp/cm ² (11.4—21.3 lbf/in ²)
Oil pressure, hot engine, full speed	3.5—4.0 kp/cm ² (50—57 lbf/in ²)

Reverse gear

Oil quality/Viscosity	Same as for engine
Oil capacity, din ³ (qts.), red. 1:1	0.4 (0.4)
Oil capacity, din ³ (qts.), red. 1.91 :1	0.55(0.5)

Combi reduction gear

Reduction gear	same oil compartment as engine's
Reversing mechanism and propeller hub	Lubricating grease Shell Alvania EP2 or similar

Lubricating oil filter

Designation	AC-DELCO, 1530838 type SA
-------------	---------------------------

Lubricating oil pump

Type	Gear wheel pump
Relief valve spring: Length, off-load	45 mm (1.7717")
Loaded with 15 N (1.5 kp = 3.3 lbf)	40 mm (1.5748")
Loaded with 46 N (4.6 kp = 10 lbf)	29 mm (1.1417")
Axial clearance of gear wheels incl. gasket	0.048—0.084 mm (0.0020—0.0033")

Fuel system

Fuel injection pump, make Bosch	0 460 302 006
Injectors, make Bosch, holders	0 431 112 001
Nozzles	0 433 171 001
Hole diameter	Four, 0.22 mm (0.0087")
Opening pressure	180 kp/cm ² (2560 lbf/in ²)
Spray angle	150°
Advance angle	12°
Injection quantity	20 mm ³ /stroke at 31.7 rev/sec (1900 rev/min)
Max. speed	40.8—42.5 rev/sec (2450—2550 rev/min)

Fine filter

Type	Bosch 0 450 133 001
Filter insert	Bosch 1 457 434 0611

Feed pump

Type	Pierburg PE 15672
Feed pressure at 40 rev/sec (2400 rev/mm)	0.65—0.85 kp/cm ² (9.2—12.0 lbf/in ²)

Electrical system

Battery voltage	12 V
Battery capacity	Max. 60 Ah
Start-generator	Bosch 0 010 350 004
Generator output, max	135W
Generator output, continuous	90 W
Starter motor output	0.74kW (1 h.p.)
Battery electrolyte specific gravity: Fully charged batter	1.275—1.285 g/cm ³
When charging has to be carried out	1.230 g/cm ³

Cooling system

Thermostat	Bellows thermostat
Starts opening at	60°C (140°F)
Fully open at	74°C (165°F)

WEAR TOLERANCES

Cylinders

Drilled with wear (or if engine has abnormal fuel consumption)	0.25 mm (0.010)
--	-----------------

Crankshaft

Main bearing and connecting rod journals	
Permitted out-of-roundness	0.06 mm (0.0024")
Permitted taper	0.05 mm (0.0020")
Max. axial play on crankshaft	0.36 mm (0.0142")

Camshaft

Bearing journals, permitted out-of-roundness	0.03 mm (0.0012")
Max. clearance between camshaft and bushings	0.15 mm (0.0060")

Valves

Max. clearance between valve stem and guide	0.16 mm (0.0063")
Edge of valve disc should be mm	1.0 mm (0.0400")

TIGHTENING TORQUES

	Nm	Kpm	Lbftf
Cylinder head nuts	70	7	51
Cylinder head stud bolts	20	2	14
Bolt for flange on crankshaft	70	7	50
Flywheel nut	180	18	130
Connecting rod bolts	50	5	36
Water pump flange	60	6	43
Main bearings	50	5	36
Nuts for fork for injectors	8	0.8	5.8

Tightening scheme for cylinder head nuts

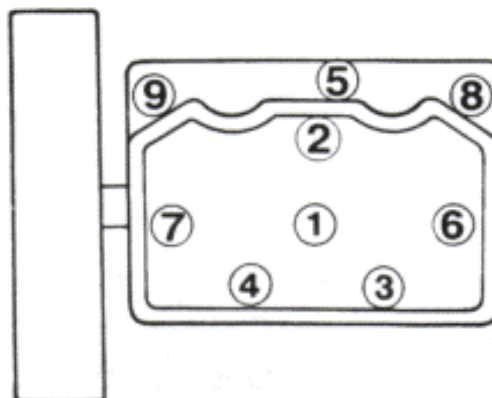

Technical Data MD7A

General

Type designation
Output at flywheel (DIN) at 43 rev/sec. (2600 rev/mm.)
Number of cylinders
Bore
Stroke
Capacity
Compression ratio
Compression pressure at starter motor speed
Direction of rotation, viewed towards flywheel
Idling speed
Oil pressure, full speed, hot engine
Oil pressure, idling, hot engine

MD7A

10 kW (13.4 h.p.)
2
76 mm (2.9921")
82 mm (3.2283")
0.744 dm³
17:1
2-2.5 MPa (20—25 kp/cm²) (284—355 lbf/in²)
Clockwise
11—13 rev/sec (650—780 rev/min)
0.35-0.40 MPa (3.5-4.0 kp/cm²) (50-57 lbf/in²)
0.08-0.15 MPa (0.8-1.5 kp/cm²) (11-21 lbf/in²)

Cylinders

Material
Bore, standard
0.25 mm (0.010") oversize
0.50 mm (0.020") oversize

Cast iron
76.00—76.03 mm (2.9921—2.9933")
76.25—76.28 mm (3.0020—3.0032")
76.50—76.53 mm (3.0118—3.0130")

Pistons

Material
Height, total
Height from gudgeon pin centre to piston crown
Piston clearance in cylinder
Pistons, standard diameter
0.25 mm (0.010") oversize
0.50 mm (0.020") oversize

Light-alloy
76.4 mm (3.0079")
51.4 mm (2.0236")
0.073—0.118 mm (0.0029—0.0046")
75.912—75.927 mm (2.9883—2.9893")
76.162—76.177 mm (2.9985—2.9991")
76.412—76.427 mm (3.0084—3.0090")

Gudgeon pins

Diameter
Gudgeon pin bushing, diameter
Clearance, gudgeon pin - bushing

28.000—28.004 mm (1.1024—1.1025")
28.0125—28.0225 mm (1.1029—1.1032")
0.0085—0.0230 mm (0.0003—0.0009")

Piston rings

Compression rings, number
Oil scraper ring, number
The upper compression ring is chromium lined
Piston rings are available for standard size, 0.250 mm (0.010") and 0.500 mm (0.020") oversize

2
1

Piston ring clearance in groove, axially:

Upper compression ring
Lower compression ring
Oil scraper ring

0.070—0.102 mm (0.0028—0.0040")
0.050—0.082 mm (0.0020—0.0030")
0.030—0.062 mm (0.0012—0.0024")

Piston ring gap in cylinder

Upper compression ring
Lower compression ring
Oil scraper ring

0.30—0.50 mm (0.0120-0.020")
0.30—0.50 mm (0.0120-0.020")
0.25—0.50 mm (0.010-0.020")

Crankshaft

Material
Crankshaft axial clearance
Main bearing radial clearance
Big-end bearings, radial clearance

Nodular iron
0.080—0.313 mm (0.0032—0.0123")
0.026—0.075 mm (0.0010—0.0030")
0.026—0.075 mm (0.0010—0.0030")

Main bearing journals

Diameter, standard	49.984—50.000 mm (1.9679—1.9685")
0.300 mm (0.0120") undersize	49.684—49.700 mm (1.9560—1.9567")
0.600 mm (0.0236") undersize	49.384—49.400 mm (1.9442—1.9449")

Main bearing shells

Thickness, standard	1.730—1.737 mm (0.0681—0.0684)
0.300 mm (0.0120") oversize	1.880—1.887 mm (0.0740—0.0743")
0.600 mm (0.0236") oversize	2.030—2.037 mm (0.0799—0.0802")

Big-end journals

Diameter, standard	49.984-50.000 mm (1.9679—1.9685")
0.300 mm (0.0120") undersize	49.684—49.700 mm (1.9560—1.9567")
0.600 mm (0.0236") undersize	49.384—49.400 mm (1.9442—1.9449")

Big-end bearing

Thickness, standard	1.730—1.737 mm (0.0681—0.0684")
0.300 mm (0.0120") oversize	1.880—1.887 mm (0.0740—0.0743")
0.600 mm (0.0236") oversize	2.030—2.037 mm (0.0799—0.0802")

Connecting rods

End play at crankshaft	0.25—0.50 mm (0.0100—0.0200")
------------------------	-------------------------------

Camshaft

End play	0.160—0.300 mm (0.0063—0.0118")
Radial clearance in bearing	0.018—0.083 mm (0.007—0.0033")
Camshaft diameter	43.992—44.008 mm (1.7320—1.7326")
Lift height of cams	5.48—5.52 mm (0.2157—0.2173")
Bushing, diameter	44.026—44.075 mm (1.7333—1.7352")

Cylinder head

Material	Special-alloy cast iron
----------	-------------------------

Intake valves

Disc diameter	32.4—32.6 mm (1.2756—1.2835")
Stem diameter	7.955—7.970 mm (0.3132—0.3138")
Valve seat angle	45° 15' - 45° 45'
Cylinder head seat angle	45°
Width of seat in cylinder head	approx 1 mm (0.040")
Clearance, hot engine	0.30 mm (0.012")

Exhaust valves

Disc diameter	27.4-27.6 mm (1.0787—1.0866")
Stem diameter	7.950—7.965 mm (0.3130—0.3136")
Valve seat angle	45° 15' - 45° 45'
Cylinder head seat angle	45°
Width of seat in cylinder head	approx 1 mm (0.040")
Clearance, hot engine	0.30 mm (0.012")

Valve guides

Length, intake valve	38 mm (1.4961")
Length, exhaust valve	38 mm (1.4961")
Bore	8.0—8.015 mm (0.3150—0.3156")
Height above cylinder head spring face	8.85—9.15 mm (0.3484—0.3602")
Clearance, valve stem-guide:	
intake valve	0.03—0.06 mm (0.0012—0.0024")
exhaust valve	0.035—0.065 mm (0.0014—0.0026")

Valve springs

Length, off-load	42.5 mm (1.6732")
Loaded with 170±10 N (17±1 kp = 37.5±2 lbf)	32 mm (1.2598")
Loaded with 300±20 N (30±2 kp = 66±4.5 lbf)	24 mm (0.9449")

Lubricating system

Engine

Oil capacity, excl. filter	2.8 litres (2.5 Imp.qts. = 2.9 US qts.)
Oil capacity, incl. filter	3.0 litres (2.6 Imp.qts. = 3.2 US qts.)
Oil quality acc. to API-system	CD (DS)
Viscosity, above +10°C (50°F)	SAE 20 W
Viscosity, below +10°C (50°F)	SAE 10 W
Oil pressure, hot engine, idling speed	0.8—1.5 kp/cm ² (11 .4—21 .3 lbf/in ²)
Oil pressure, hot engine, full speed	3.5—4.0 kp/cm ² (50—57 lbf/in ²)

Reverse gear

Oil quality/Viscosity	Same as for engine
Oil capacity, din ³ (qts.), red. 1:1	0.4 (0.4)
Oil capacity, din ³ (qts.), red. 1.91:1	0.55 (0.5)

Combi reduction gear

Reduction gear	Same oil compartment as engine's
Reversing mechanism and propeller hub	Lubricating grease Shell Alvania EP2 or similar

Lubricating oil pump

Type	Gear wheel pump
Relief valve spring: Length, off-load	45 mm (1 .7717")
Loaded with 15 N (1.5 kp = 3.3 lbf)	40 mm (1.5748")
Loaded with 46 N (4.6 kp = 10 lbf)	29 mm (1 .1417")
Axial clearance of gear wheels incl. gasket	0.048—0.084 mm (0.0020—0.0033")

Fuel system

Fuel injection pump, make Bosch (Up to engine no 19999)	0 460 302 008
Fuel injection pump CAV (From engine no 20000)	0 3222 F070
Injectors, make Bosch, holders	0 431 112 001
Nozzles	0 433 171 009
Hole diameter	Four 0.23 mm (0.0091")
Opening pressure	185—193 kp/cm ² (2631—2744 lbf/in ²)
Spray angle	150°C
Advance angle, Bosch pump	11°± 1° b.t.d.c.
Advance angle, CAV pump	14°± 0.1° b.t.d.c.
Injection quantity, Bosch pump	18±0.5 mg/stroke at 43 rev/sec. (2580 rev/min)
Injection quantity CAV pump	17.5±0.5 mg/stroke at 43 rev/sec. (2580 rev/mm)

Feed pump

Type	Pierburg PE 15672
Feed pressure at 42 rev/sec (2500 rev/mm)	0.65—0.85 kp/cm ² (9.2-12.0 lbf/in ²)

Electrical system

Battery voltage	12 V
Battery capacity	Max. 120 Ah
Starter motor, Bosch	0 001 311 115
Starter motor output	1.1 kW (1.48 h.p.)
Alternator SEV Marchal	70 229712
Alternator output	490W 35A
Battery electrolyte specific gravity: Fully charged battery..	1.275—1.285 g/cm ³
When charging has to be carried out	1.230 g/cm ³

Cooling system

Thermostat	Bellows thermostat
Starts opening at	60°C (140°F)
Fully open at	74°C (165°F)

WEAR TOLERANCES

Cylinders

Rebore for wear (or if engine has abnormal fuel consumption)	0.25 mm (0.010")
---	------------------

Crankshaft

Main bearing and connecting rod journals	
Permitted out-of-roundness	0.06 mm (0.0024")
Permitted taper	0.05 mm (0.0020")
Max. axial play on crankshaft	0.40 mm (0.157")

Camshaft

Bearing journals, permitted out-of-roundness	0.03 mm (0.0012")
Max. clearance between camshaft and bushings	0.15 mm (0.0060")

Valves

Max. clearance between valve stem and guide	0.15 mm (0.0060")
Edge of valve disc should be mm	1.0 mm (0.0400")

Tightening torques

	Nm	Kpm	Lbf ft
Cylinder head nuts	70	7	51
Cylinder head stud bolts	20	2	14
Bolt for flange on crankshaft	70	7	51
Flywheel nut	180	18	130
Connecting rod bolts	70	7	51
Water pump flange (Bosch fuel injection pump)	60	6	43
Water pump flange (CAV fuel injection pump)	80	8	58
Main bearings	50	5	36
Nuts for fork for injectors	8	0.8	5.8
Bolt for intermediate gear transmission	70	7	51
Starter motor bolt	70	7	51
Bolt, front engine mounting	45	4.5	33
Bolt, rear engine mounting	45	4.5	33

Tightening scheme for cylinder head nuts

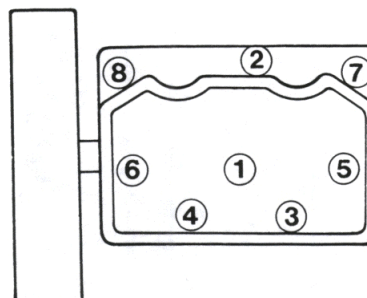

Cross section

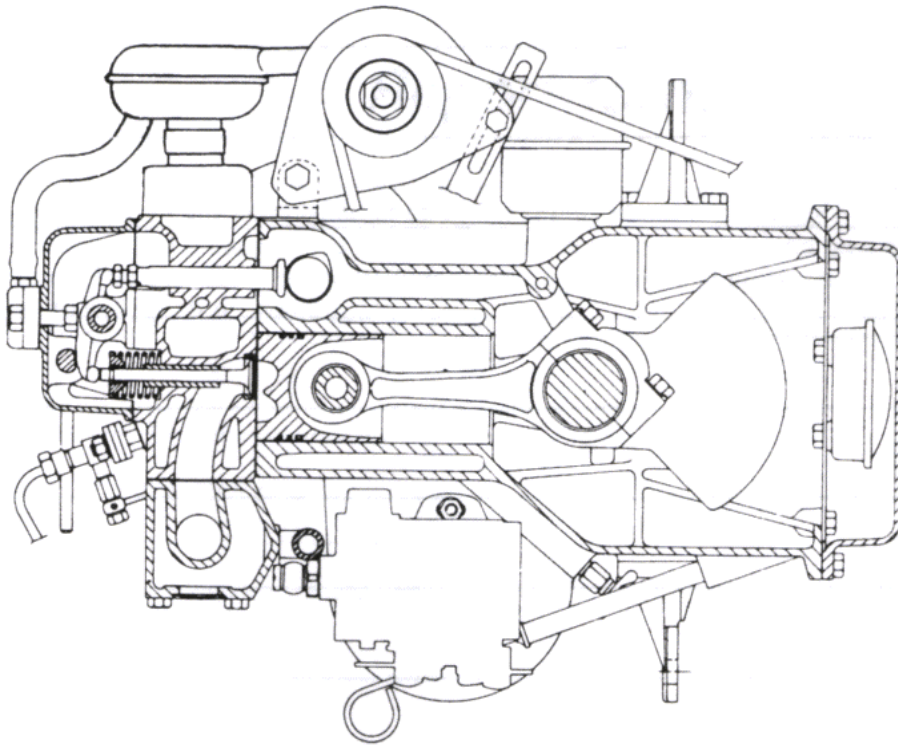

Longitudinal section

