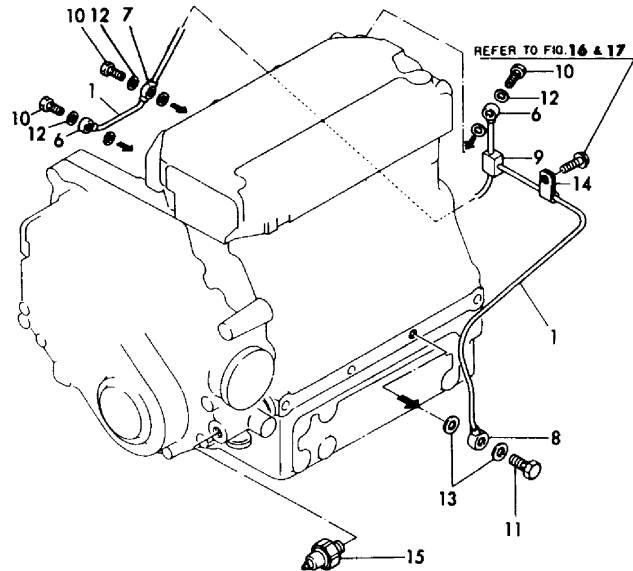

Fig.31. LUB. OIL LINE

Fig.31 潤滑油パイプ
LUB.OIL PIPE



OCF10-G50602 31. LUB. OIL LINE

(A)=3GM30
(B)=3GM30VE
(C)=3GM30B

(D)=3GM30C
(E)=3GM30F
(F)=3GM30FVE

REF.	LEV.	PARTS NO.	DESCRIPTION	Q'TY						I	R
				(A)	(B)	(C)	(D)	(E)	(F)		
1	1	128370-39200	PIPE, LUB OIL	1	1	1	1	1	1		
6	2	103288-39170	JOINT 8	2	2	2	2	2	2		
7	2	124450-39180	JOINT	1	1	1	1	1	1		
8	2	124160-39540	JOINT, PIPE 10	1	1	1	1	1	1		
9	2	121750-39550	3-WAY JOINT	1	1	1	1	1	1		
10	1	124550-59820	BOLT 8, PIPE JOINT	3	3	3	3	3	3		
11	1	124160-39140	BOLT 10, PIPE JOINT	1	1	1	1	1	1		
12	1	23414-080000	GASKET 8, ROUND	6	6	6	6	6	6		
13	1	23414-100000	GASKET 10, ROUND	2	2	2	2	2	2		
14	1	124450-39240	RETAINER, PIPE	1	1	1	1	1	1		
15	1	124060-39451	SENDER, OIL PRESSURE	1	1	1	1	1	1		