

The ON7WP special: a space efficient high power antenna using non-resonant traps.

Trap antennas are popular on HF. The W3DZZ is a dual band antenna for 80-40m that is used by many hams around the world. Unfortunately the design is only using part of the antenna on 40m and the traps are prone to arcing with high power.

Very little is found on the web about this amazing type of antennas. Very few commercial designs use the principle as well (Butternut verticals).

This article describes the design, construction and tuning of a dual band antenna for 80 and 40 meter but it can be scaled to any other two bands using the same formula.

Design:

Determine the two wanted center frequencies, in my case 3,650 and 7,150 MHz. Calculate the mean arithmetic frequency as the square root of the product of both frequencies.

$$\text{SQR}(3,65 \times 7,15) = 5,11 \text{ MHz}$$

This will be the trap frequency. It is not a real "trap", at the lowest frequency the coil will be dominant, at the highest frequency the capacitor will be dominant.

Now for a resonant circuit on 5,11 MHz we want X_L at 3,65 MHz = X_c at 7,15 MHz. We look for a coil that resonates our antenna on the lowest frequency. This value X_L or X_c of 330 ohm we put in our EZNEC drawing, as a center load of the dipole. We design the full antenna length also approximately to this frequency taking into account the shortening factor of around 95%.

So we end up with 28m total length and two center coils of 10 uH. In order to resonate the antenna at 7,15 MHz we need a (high voltage) capacitor of 90 pF we place in parallel with the coil.

Construction:

Antenna wire is preferably 2,5 mm² stranded tinned wire. We need 4 equal lengths of 7 meter.

In the middle we put a current balun, something like 10 turns of preferably Teflon coax over a T200 core made of 31 material. (43 material is more for 20 MHz and up)

The traps we built on white PVC tubing of 40 mm. For 10 uH use 18 turns of 1,7mm CU (on 3mm wall thickness tubing 40mm outer diameter). Preferably do not use dark colors as these can contain carbon.

The capacitor is made out of RG58U coax. Start with 1 meter or 100 pF in parallel with the coil.

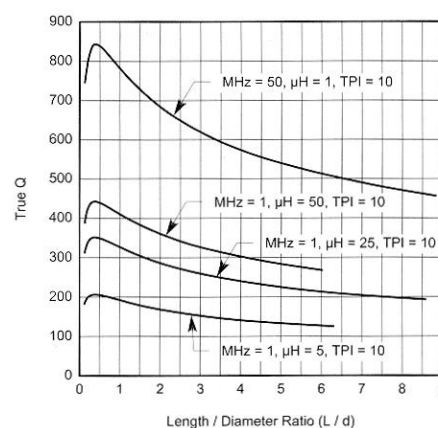

Optimum coil dimensions:

Tuning:

Start by the lowest frequency. Shorten the end of the antenna until you reach your design goal. 14 meter should put you somewhere around 3,5 MHz.

Tuning to 3,650 MHz should give you like 150-200 kHz bandwidth between 3:1 SWR, something your rig built in tuner can easily handle.

Then go to the 40 meter design frequency and cut both coax capacitors until you are where you want to be. SWR should stay below 3:1 from 6,85 till 7,45 MHz so 600 kHz bandwidth.

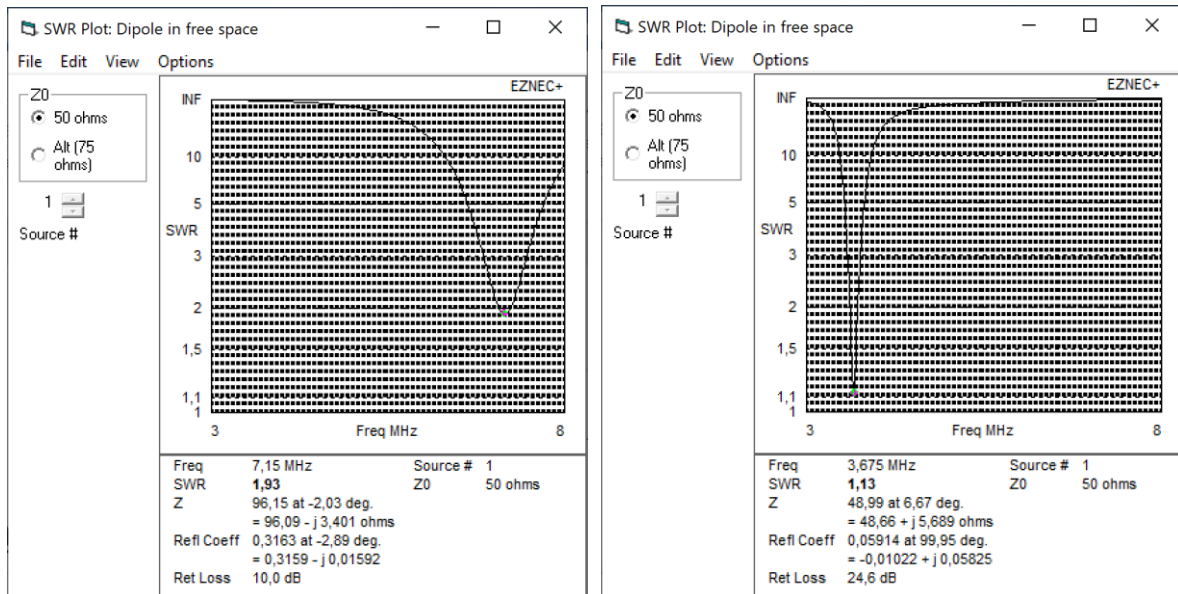

Performance:

The antenna is perfect for NVIS on 80 meter and a good DX performer on 40 meter as can be seen from the elevation patterns. Almost 8 dBi at 29 degrees elevation on 40 meter and 6,2 dBi upwards for NVIS on 80 meter.

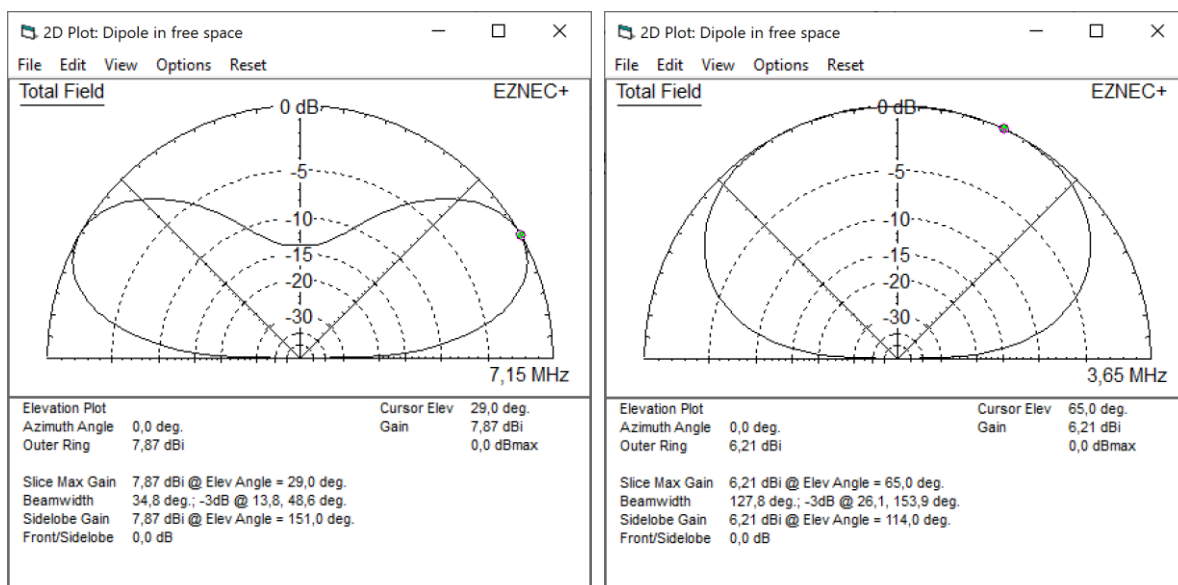

Front to side is -13 dB on 40 meter. Omni pattern on 80 meter as seen in 3D model below:

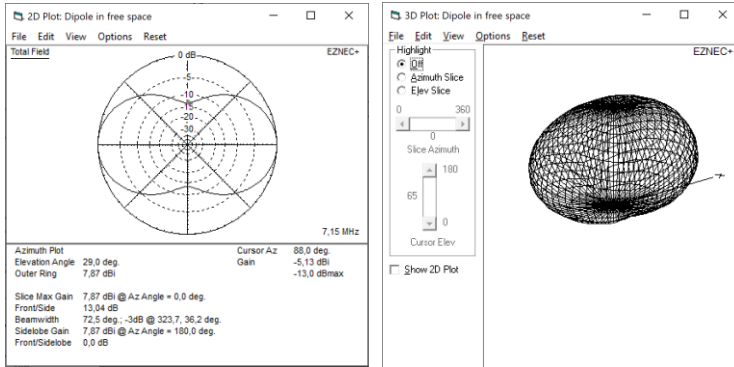

Comments ?

Appreciated at pedro.wyns@gmail.com

--

Pedro M.J. Wyns - Lecturer Electronics and Telecommunications
ThomasMore university of applied sciences

Address: Mechelsesteenweg 14, B-2220 Heist-op-den-Berg, Belgium
Cellphone +32 479 911 296 (preferred mode whatsapp)
LinkedIn: <https://www.linkedin.com/in/on7wp>