

## A simple DIY alternator charge system for LiFePO4 batteries (12V system) on boats.

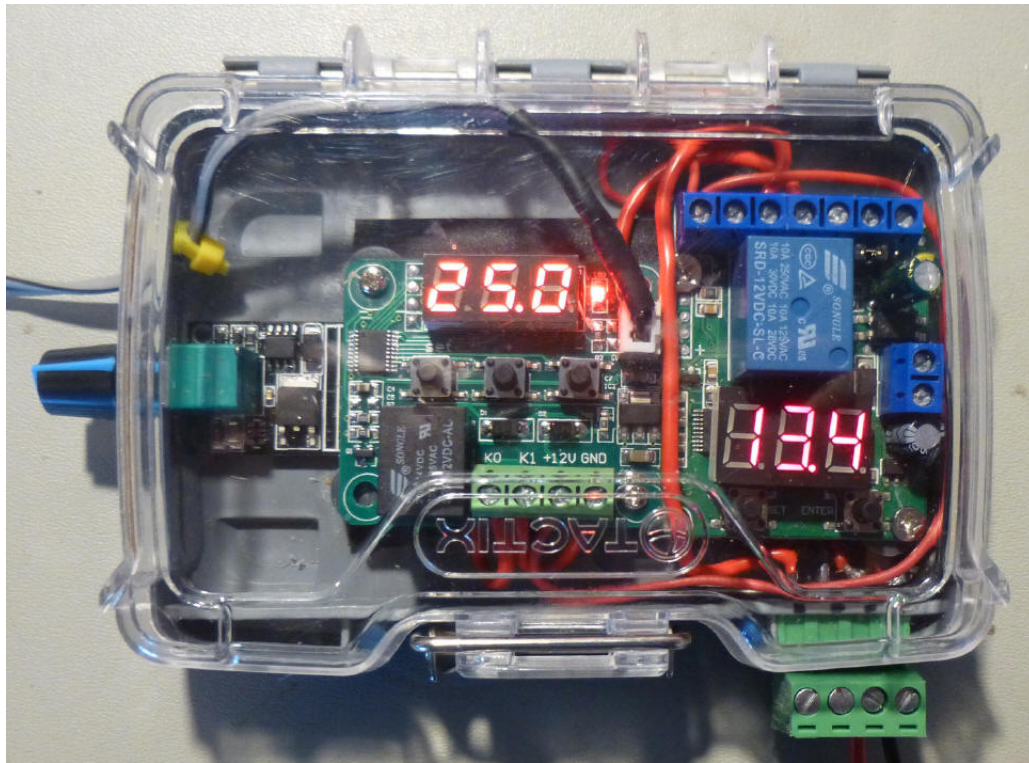

This allows an existing alternator of any capacity to be used for charging LiFePO4 batteries on a boat. It can be put together from a few low-cost components by anyone with a basic understanding of electricity. Note: In the following text both the full name LiFePO4 and the abbreviation LFP are being used interchangeably.

There is a lot of misinformation around regarding charging LiFePO4 batteries with an alternator. Boat owners are often talked into purchasing a very expensive new alternator and/or smart alternator controller for their boat's engine, because the old one which was used for charging lead-acid batteries is said to be unsuitable for LiFePO4 batteries. Not necessary!

Let's first have a quick look at the alternator charging process in general:

The output of an alternator is controlled by a relatively small DC variable current through the field coil (rotator), via brushes. This current is often no more than 6 Amps max for many alternators. The stronger the magnetic field created by the field current, the more output the alternator delivers, up to its maximum capacity.

Standard alternators have an internal Voltage-regulator that prevents the battery voltage from rising above a fixed voltage, sometimes with temperature compensation. For a 12V system this is often 14V. For efficient charging of lead-acid house batteries on boats the internal voltage regulator is often replaced by a "smart" regulator with 3 stages: bulk, absorption and float. During the bulk stage the charging process is no different from a standard internal V-regulator. As long as the set voltage (the absorption Voltage) has not been reached, the alternator delivers as much as it can. However, the smart alternator allows the battery voltage to rise higher, to the absorption level, typically 14.4V, thereby pumping more Amps into the batteries. Fortunately the Voltage of lead-acid batteries builds up quickly, which limits

the output of the alternator. If not, it would have to work too hard for a long period and it would become too hot. The latter can still happen during charging of large capacity nearly empty deep-cycle batteries if the bulk stage takes a long time to complete. When the absorption voltage has been reached, the lead-acid battery is about 80% fully charged. The voltage is now kept at this level for a certain period of time. During the absorption stage the state-of-charge (SoC) slowly increases and the charge current tapers off. Only when the charge current in Amps is 1 or 2 percent of the Ahr capacity, the battery is fully charged. Once the absorption stage comes to an end, the voltage is kept at a lower level, the "float" level, e.g. 13.5V.

So far the charging of lead-acid batteries.

The process is different when charging LiFePO4 batteries. These batteries have a low internal resistance and the Voltage only changes a little throughout most of the charge process, until they are 90% full. Therefore, if the same alternator controller as for lead-acid batteries is used, the alternator tries to deliver its maximum capacity for a long period of time and doesn't leave the bulk charge stage until the absorption voltage is reached. As a result, the alternator can become very hot and can burn out. This happens for both standard internal regulators and smart regulators. In fact, no regulation takes place at all. Voltage regulation only kicks in when the absorption voltage (or fixed voltage) is reached and then it is too late. There are videos with smoking alternators on Youtube, to demonstrate "how NOT to charge LiFePO4 batteries".

The only way undesired high temperatures and alternator failure can be prevented is by limiting the alternator output, by limiting the field current.

Manufacturers have come up with several ways to make existing smart alternators "LiFePO4 ready" by introducing a selectable LiFePO4 profile, but in most cases output regulation is still on the basis of battery Voltage, not on Amperage.

One solution is to install a "hot rated" alternator that can deliver its maximum capacity for long periods of time, but it cannot be guaranteed that even such an alternator does not get over worked resulting in a shortened life-span. Also care should be taken that the manufacturer's specified maximum charge current (0.5C) for the batteries is not exceeded.

The use of a DC-DC converter is also promoted by some as a method of charging LiFePO4 batteries, but in this context this is basically a complicated and expensive way of limiting charge current, in most cases to a fixed max amperage, much below what the batteries can accept.

The ideal smart alternator controller for LiFePO4 batteries has to monitor (and action on) 4 things:

1. Current (Amps), i.e. the output of the alternator.
2. Voltage
3. Alternator temperature
4. (for optimal performance, optional) Alternator RPM

I have designed and built such an alternator controller with some useful extra features, but this is not a commercial product and only for personal use on my own boat. See Wally100.pdf

The Wally100 uses a separate shunt with current sense amplifier to measure alternator Amps, a V-sensor, a temperature sensor on the alternator and also monitors the alternator RPM by counting pulses output from the alternator's single phase W-connection.

## A simple DIY charger

As a backup for the Wally100 and after receiving several requests from other yachties for a simple DIY solution, I have also explored and tested some practical ways of putting a simple, low-cost system together that allows safe and fast charging of LFP batteries using the existing alternator. Without the sophistication of a microprocessor based controller, but still pretty efficient.

Most electrical systems on boats these days include a battery monitor. This is a prerequisite for the simple charging systems described below, as it is important to be able to determine the amperage that can comfortably be output by the alternator without overheating. If there is no battery monitor, an ammeter can be used instead. Where the Wally100 'smart' controller monitors alternator RPM and automatically adjusts the charging current depending on how fast the alternator spins, the simple system does not take RPM into account. However, manual adjustment of the charge current can be made, if required, to optimise charging depending on engine RPM's. At high RPM's the higher speed of the alternator fan provides better cooling, so the alternator can work harder without overheating. In the simple system below a safe current limit can be set for worst case (=low RPM) use, but the limit can be increased manually while running the boat's engine at higher RPM's at cruising speed.

### Components of a simple LFP charging system

The 3 important components in the simple charging system are the current limiting device, the (battery) Voltage sensor and temperature control device:

1. Field current limiting device. The (variable) setting determines the strength of the field current and therefore the alternator output. It is connected to the + of the LFP batteries if one side of the alternator field coil is connected to ground. The simplest current limiter is a rheostat (variable wire-wound resistor). This works very reliably but the disadvantage is its bulkiness and it produces heat. A fan is required for cooling, which adds to the bulkiness.

A compact alternative is a MosFET PWM (Pulse Width Modulation) controller. These are available as electric motor speed controllers or dimmers for lighting. An on-board potentiometer is used for setting the FET "duty cycle", i.e. the length of the high frequency pulses. It switches negative (gnd) current and must therefore be connected to the negative side of the alternator field coil. If one side of the field coil is wired to ground (via the brush), this has to be disconnected and the controller board has to be connected instead. Usually the alternator brush holder and standard V-reg are combined. This unit has to be taken off the alternator, usually by undoing 2 screws. Now the standard regulator has to be disabled and 2 connections to the brushes have to be made. For some alternators (Bosch) brush holders without integral regulator are available, which simplifies installation.

2. Battery Voltage: An adjustable Voltage switch with relay monitors the battery Voltage and when the set Voltage is reached, the relay opens. By running the field current to the alternator via the relay, the field current is interrupted when the relay opens. By setting the Voltage to the maximum safe charge Voltage for the LFP batteries, e.g. 13.9V for a 12V system, charging stops when the relay opens. When the Voltage has dropped to a certain level, say 13.2V for a 12V system, the relay closes and charging

can resume.

3. Alternator temperature control. An adjustable thermostat with temperature sensor on the alternator controls alternator temperature. The thermostat relay opens when the maximum allowed operating temperature for the alternator (minus a safety margin) is reached, e.g. 60°C and closes e.g. at 40°C. Temperatures depending on alternator model.

The thermostat is connected in series with the Voltage switch, so the field current is also interrupted when the safe operating temperature range is exceeded. Charging stops and the alternator can cool off until the set safe operating temperature is reached. This is a safety mechanism and setting of the field current should be such that the temperature normally stays well within the max temperature.

note: Once the maximum charge current, the maximum Voltage and the cool-down temperature have been set, charging of the LFP batteries does not require constant monitoring. This in contrast to charging lead-acid batteries. Lead-acid batteries can also be charged using manual regulation, but this requires constant attention as the Voltage rises with the building up of internal battery resistance and care should be taken not to exceed gassing Voltage. This problem does not exist when charging LFP batteries. Charging is simply stopped when the set Voltage is reached and the batteries are full, so there is no need for constant (visual) monitoring.



fig 1. PWM controller

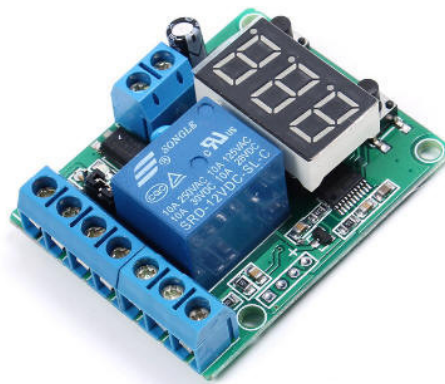

fig 2. Voltage switch

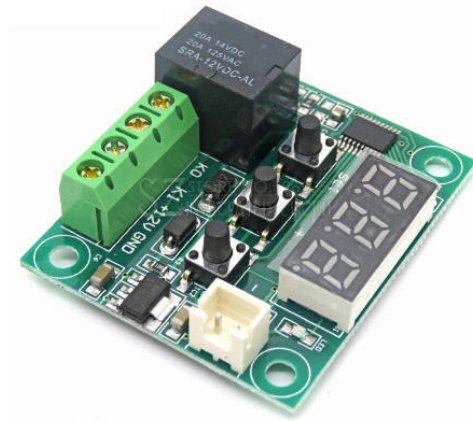

fig 3. Thermostat

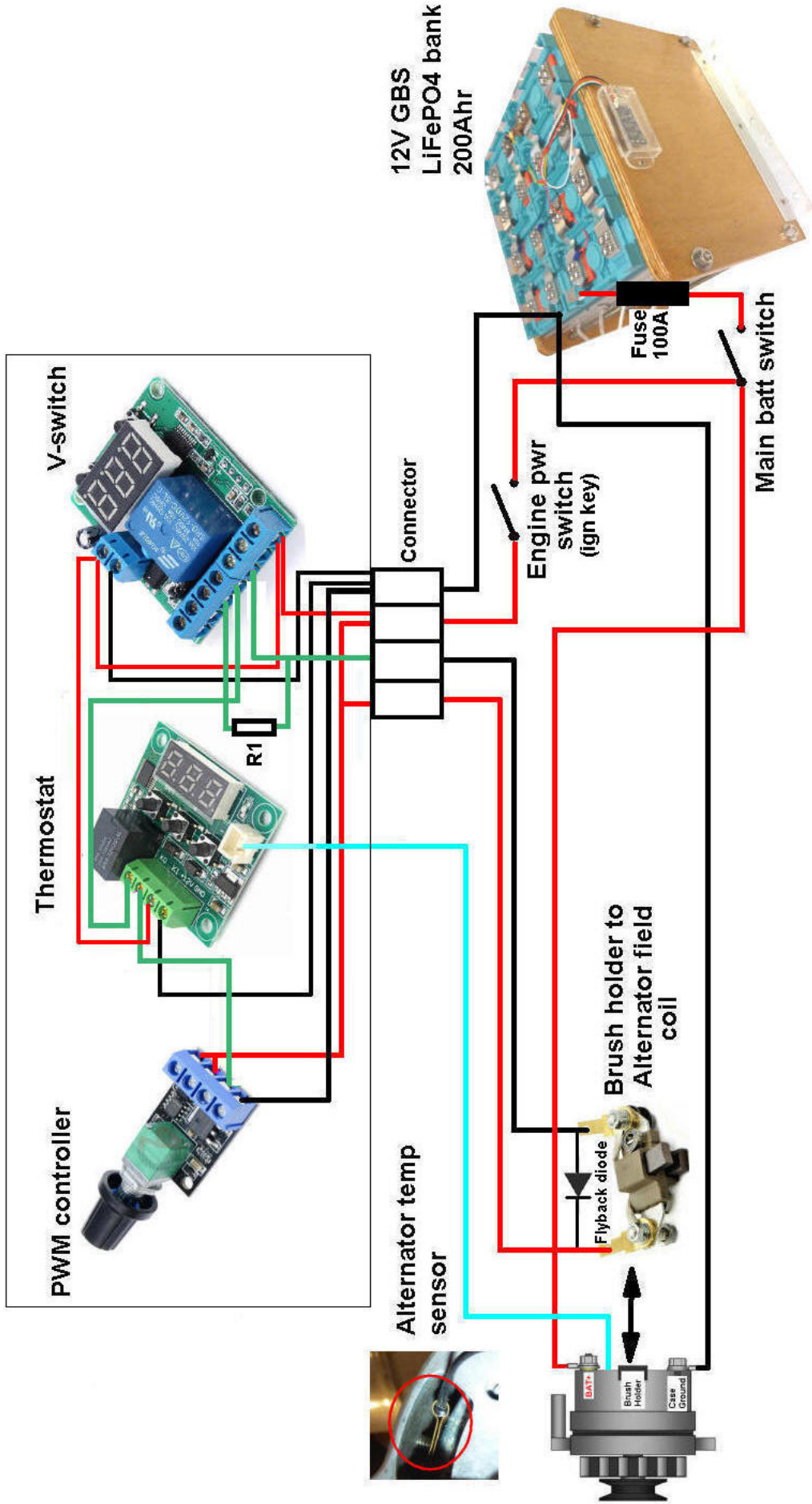

fig 4. Rheostat (as alternative current limiter)

### Wiring it all together (using the PWM controller)

The three key-components (boards) can be purchased online at a total cost of around \$10. Furthermore, some wiring, a box, a connector and a diode are needed.

# A simple alternator charging system for LiFePO4 batteries



## Using a rheostat instead of a PWM controller

The wiring of a rheostat-based charger is very similar to the version with PWM controller, but a larger box and fan are required for cooling. The advantage is that it is a very robust solution with minimal electronics. The end product can be something like this:



---

WB