

# RULES FOR CLASSIFICATION

## Yachts

Edition July 2019

### Part 3 Hull

## Chapter 7 Rudder, foundations and appendages

---

The content of this service document is the subject of intellectual property rights reserved by DNV GL AS ("DNV GL"). The user accepts that it is prohibited by anyone else but DNV GL and/or its licensees to offer and/or perform classification, certification and/or verification services, including the issuance of certificates and/or declarations of conformity, wholly or partly, on the basis of and/or pursuant to this document whether free of charge or chargeable, without DNV GL's prior written consent. DNV GL is not responsible for the consequences arising from any use of this document by others.

---

**The electronic pdf version of this document, available free of charge from <http://www.dnvgl.com>, is the officially binding version.**

---



## FOREWORD

DNV GL rules for classification contain procedural and technical requirements related to obtaining and retaining a class certificate. The rules represent all requirements adopted by the Society as basis for classification.

© DNV GL AS July 2019

Any comments may be sent by e-mail to [rules@dnvgl.com](mailto:rules@dnvgl.com)

This service document has been prepared based on available knowledge, technology and/or information at the time of issuance of this document. The use of this document by others than DNV GL is at the user's sole risk. Unless otherwise stated in an applicable contract, or following from mandatory law, the liability of DNV GL AS, its parent companies and subsidiaries as well as their officers, directors and employees ("DNV GL") for proved loss or damage arising from or in connection with any act or omission of DNV GL, whether in contract or in tort (including negligence), shall be limited to direct losses and under any circumstance be limited to 300,000 USD.

## CURRENT – CHANGES

This document supersedes the July 2018 edition of DNVGL-RU-YACHT Pt.3 Ch.7.

Changes in this document are highlighted in red colour. However, if the changes involve a whole chapter, section or subsection, normally only the title will be in red colour.

### Changes July 2019, entering into force 1 January 2020

Only editorial changes have been made.

### Editorial corrections

In addition to the above stated changes, editorial corrections may have been made.

## CONTENTS

|   |           |
|---|-----------|
| <b>Current – changes.....</b>                       | <b>3</b>  |
| <b>Section 1 General.....</b>                       | <b>6</b>  |
| <b>1 General.....</b>                               | <b>6</b>  |
| <b>2 Materials and workmanship.....</b>             | <b>7</b>  |
| <b>3 Arrangement of appendages.....</b>             | <b>8</b>  |
| <b>Section 2 Metall rudder.....</b>                 | <b>9</b>  |
| <b>1 General.....</b>                               | <b>9</b>  |
| <b>2 Rudder force and torque.....</b>               | <b>11</b> |
| <b>3 Scantlings of the rudder stock.....</b>        | <b>14</b> |
| <b>4 Sole piece.....</b>                            | <b>19</b> |
| <b>5 Rudder horn of semi spade rudders.....</b>     | <b>20</b> |
| <b>6 Rudder couplings.....</b>                      | <b>23</b> |
| <b>7 Rudder body, rudder bearings.....</b>          | <b>29</b> |
| <b>8 Design yield moment of rudder stock.....</b>   | <b>34</b> |
| <b>9 Stopper, locking device.....</b>               | <b>34</b> |
| <b>Section 3 Composite rudders.....</b>             | <b>35</b> |
| <b>1 General.....</b>                               | <b>35</b> |
| <b>2 Rudder design loads.....</b>                   | <b>36</b> |
| <b>3 Rudder bearings.....</b>                       | <b>38</b> |
| <b>4 Rudder scantlings.....</b>                     | <b>38</b> |
| <b>5 Rudder equipment.....</b>                      | <b>38</b> |
| <b>Section 4 Fin stabilizers.....</b>               | <b>39</b> |
| <b>1 General.....</b>                               | <b>39</b> |
| <b>2 Integration into the ship's structure.....</b> | <b>39</b> |
| <b>Section 5 Waterjets.....</b>                     | <b>40</b> |
| <b>1 Design principles.....</b>                     | <b>40</b> |
| <b>2 Duct design.....</b>                           | <b>40</b> |
| <b>3 Design loads.....</b>                          | <b>41</b> |
| <b>4 Allowable stresses.....</b>                    | <b>41</b> |
| <b>5 Bolt connections.....</b>                      | <b>42</b> |
| <b>Section 6 Foundations.....</b>                   | <b>43</b> |
| <b>1 General.....</b>                               | <b>43</b> |

|  |           |
|--|-----------|
| <b>2 Foundations.....</b>  | <b>43</b> |
| <b>3 Foundations for main propulsion engines.....</b>              | <b>43</b> |
| <b>4 Foundations for auxiliary engines.....</b>                    | <b>46</b> |
| <b>5 Foundations for deck machinery and mooring equipment.....</b> | <b>46</b> |
| <b>Section 7 Propeller shaft brackets.....</b>                     | <b>47</b> |
| <b>1 General.....</b>  | <b>47</b> |
| <b>2 Metallic shaft brackets.....</b>                              | <b>47</b> |
| <b>3 Composite shaft brackets.....</b>                             | <b>50</b> |
| <b>Section 8 Sailing yacht keels.....</b>                          | <b>51</b> |
| <b>1 General.....</b>  | <b>51</b> |
| <b>2 Keel and keel attachment scantling determination.....</b>     | <b>52</b> |
| <b>Section 9 Chainplates for sailing yacht.....</b>                | <b>54</b> |
| <b>1 General.....</b>  | <b>54</b> |
| <b>2 Chainplates and substructures.....</b>                        | <b>54</b> |
| <b>Changes – historic.....</b>                                     | <b>56</b> |

## SECTION 1 GENERAL

### 1 General

#### 1.1 Introduction

The requirements in this chapter apply to rudder, foundations and appendages necessary for satisfactory performing of the following functions:

- propulsion
- steering
- dynamic lift.

Such appendages are:

- rudders
- rudder posts
- shaft brackets
- foils.

Further, the requirements will include structural strength of hull foundations of above items, and appended propulsion units such as waterjets.

Requirements for steering arrangement are given in [Sec.2](#) for metall rudders and [Sec.3](#) for composite rudders.

Requirements for steering gear, hydraulic cylinders, rotating parts, propellers and impellers with shafting bearings for such are given in [Pt.4](#).

Requirements for side thrusters and other appliances intended for manoeuvring or positioning purposes are given in [Pt.4](#).

#### 1.2 Documentation requirements

The documentation requirements are given in [Ch.1 Sec.3](#).

#### 1.3 Certification requirements

##### 1.3.1

For products that shall be installed on board, the builder shall request the manufacturers to order certification as described in [Table 1](#).

**Table 1 Certification requirements**

| <i>Object</i>                         | <i>Certificate type</i> | <i>Issued by</i> | <i>Certification standard*</i> | <i>Additional description</i>  |
|---------------------------------------|-------------------------|------------------|--------------------------------|--|
| Material used in all structural parts | MC                      | Society          |                                | Including hull plating forming part of a waterjet insert, shaft brackets and fin |
| Rudder                                | MC                      | Society          |                                | Structural parts   |
|                                       |                         |                  |                                | Shaft  |
|                                       |                         |                  |                                | Pintles  |
|                                       |                         |                  |                                | Stock  |

| <i>Object</i>  | <i>Certificate type</i> | <i>Issued by</i> | <i>Certification standard*</i> | <i>Additional description</i>       |
|--|-------------------------|------------------|--------------------------------|-------------------------------------|
|  |                         |                  |                                | Carrier                             |
|  |                         |                  |                                | Bolts for flanged couplings         |
|  | MC                      | Manufacturer     |                                | Stoppers                            |
|  |                         |                  |                                | Bolts, except for flanged couplings |
| <p>*Unless otherwise specified the certification standard in the Society's rules.<br/>           PC = Product Certificate, MC = Material certificate</p> |                         |                  |                                |                                     |

**1.3.2**

For general certification requirements, see [DNVGL-CG-0550 Sec.4](#).

**1.3.3**

For a definition of the certification types, see [DNVGL-RU-SHIP Pt.1 Ch.1 Sec.4](#) and [DNVGL-CG-0550 Sec.3](#).

**2 Materials and workmanship**

For bolts connecting thrusters and water jets to the hull, see [DNVGL-RU-SHIP Pt.4 Ch.5 Sec.3](#).

**2.1 Material combinations**

When an appendage, or parts connected to it, is fabricated from another material than the hull, such that a risk for galvanic corrosion arises, the appendage shall be galvanically isolated from the hull. This can be accomplished by the use of gaskets or seals from adequate material or adequate coating of at least one of the mating surfaces between hull and appendage. Cathodic protection may also be accepted as an alternative.

**2.2 Welded constructions**

**2.2.1** Welds shall be full penetration welds only. Necessary preheating shall be applied for parts of substantial thickness, according to approved procedure.

**2.2.2** 100% non destructive testing shall be carried out on following welds:

- connection appendage/ hull
- connections between separate parts of the appendage (e.g. shaft boss/bracket arm)
- important hull welds
- connection welds for ears for hydraulic cylinders and important link members
- weld in way of shaft boss.

**2.2.3** All welds to be ground flush and corners rounded well off.

**2.3 Cast constructions**

**2.3.1** Casts for heavily loaded parts are subject to requirements as for propeller blades (see [Pt.2](#)) with respect to certification and testing.

**2.3.2** Surface finish shall be closely examined, also after removal of lifting ears etc.

## 2.4 Fibre Reinforced Plastic(FRP) constructions

**2.4.1** For FRP constructions it is referred to Ch.5 with respect to material selection, certification and design.

**2.4.2** Any over-lamination of metal parts shall take place after thorough grinding of metal surfaces and according to approved procedure.

## 3 Arrangement of appendages

### 3.1 Functional requirements

**3.1.1** Within operational conditions, propulsion, steering and dynamic lift (if applicable) shall not be unduly impaired by the craft's motions and accelerations.

**3.1.2** Longitudinal and transverse locations of appendages, and forces transmitted by appendages to the craft's hull shall be such that acceptable manoeuvrability is maintained within the speed range.

Steering of twin propulsion craft only by propulsion thrust variations may be accepted only if each of the propulsion units is arranged with full redundancy.

Generally, rudder area should be sufficient to ensure that the craft can keep a steady course with only one engine running, and at slow speed.

**3.1.3** The arrangement of appendages shall be such that within the speed range, any sudden manoeuvre will not cause loss of control or lead to dangerous situations.

### 3.2 Protection and accessibility

**3.2.1** Water intakes to tunnels (e.g. for water jet installations) shall be designed to give adequate protection against being clogged by debris, etc. Any outside protruding links, hydraulic equipment or other important parts for the functions listed in [1.1] shall be adequately protected against mechanical damage.

**3.2.2** Cathodic protection shall be arranged to the extent considered necessary.

**3.2.3** Hollow constructions like rudders, welded shaft brackets etc. shall be hydraulically tested with an internal test pressure of:

$$p_o = 10 T \text{ (kPa)}, \text{ minimum } 20 \text{ kPa}$$

where T is the fully loaded draft of the craft at rest in meters.

Means for draining shall be provided. After pressure test internal surfaces shall be covered by coating.

**3.2.4** Items listed in [3.2.1] shall be accessible for inspection and immediate remedial action. For water jets, inspection hatches shall be arranged close to the impeller.

**3.2.5** Housings for gear systems, water jet impellers etc. shall be bolted to the hull to facilitate removal for servicing.

## SECTION 2 METALL RUDDER

### 1 General

#### 1.1 Manoeuvring arrangement

**1.1.1** Yachts shall be provided with a manoeuvring arrangement which will guarantee sufficient manoeuvring capability.

**1.1.2** The manoeuvring arrangement includes all parts, from the rudder and steering gear to the steering position necessary for steering of yachts.

**1.1.3** Rudder stock, rudder coupling, rudder bearings and rudder body are dealt with in this section. The steering gear shall comply with references given in [Pt.4 Ch.9](#).

**1.1.4** The steering gear compartment shall be readily accessible and, as far as practicable, separated from machinery space.

**Note:**

Concerning use of non-magnetisable material in the wheel house in way of a magnetic compass, the requirements of the national administration concerned shall be observed.

---e-n-d---o-f---n-o-t-e---

#### 1.2 Structural details

**1.2.1** Effective means shall be provided for supporting the weight of the rudder body without excessive bearing pressure, e.g. by a rudder carrier attached to the upper part of the rudder stock. The hull structure in way of the rudder carrier shall be suitably strengthened.

**1.2.2** Suitable arrangements shall be provided to prevent the rudder from lifting.

**1.2.3** The rudder stock shall be carried through the hull either enclosed in a watertight trunk, or glands shall be fitted above the deepest load waterline, to prevent water from entering the steering gear compartment and the lubricant from being washed away from the rudder carrier. If the top of rudder trunk is below the deepest waterline, two separate stuffing boxes shall be provided.

## 1.3 Rudder size (only motor yachts)

### Guidance note:

In order to achieve sufficient manoeuvring capability, the size of the movable rudder area  $A$  should be not less than obtained from following equation:

$$A = c_1 \cdot c_2 \cdot c_3 \cdot c_4 \cdot \frac{1.75 \cdot L \cdot T}{100} [\text{m}^2]$$

where:

- $c_1$  = factor for yacht type
  - = 1.0 in general
- $c_2$  = factor for rudder type
  - = 1.0 in general for motor yachts
  - = 0.9 for semi-spade rudders
  - = 0.7 for high lift rudders
- $c_3$  = factor for rudder profile
  - = 1.0 for NACA-profiles and plate rudder
  - = 0.8 for hollow profiles and mixed profiles
- $c_4$  = factor for rudder arrangement
  - = 1.0 for rudders in propeller jet
  - = 1.5 for rudders outside propeller jet.

For semi-spade rudders 50% of the projected area of the rudder horn may be included into the rudder area  $A$ . If several rudders are arranged, the area of each rudder can be reduced by 20%.

---e-n-d---o-f---g-u-i-d-a-n-c-e---n-o-t-e---

## 1.4 Materials

**1.4.1** For materials for rudder stock, pintles, coupling bolts, etc. see [DNVGL-RU-SHIP Pt.2](#). Special material requirements shall be observed for ice notations.

**1.4.2** In general, materials having a minimum nominal upper yield point  $R_{eH}$  of less than 200 N/mm<sup>2</sup> and a minimum tensile strength of less than 400 MPa or more than 900 N/mm<sup>2</sup> shall not be used for rudder stocks, pintles, keys and bolts. The requirements of this section are based on a material's minimum nominal upper yield point  $R_{eH}$  of 235 MPa.

**1.4.3** Before significant reductions in rudder stock diameter due to application of steels with  $R_{eH}$  exceeding 235 MPa are accepted, the Society may require the evaluation of elastic rudder stock deflections. Large deflections should be avoided in order to avoid excessive edge pressures in way of bearings.

**1.4.4** Permissible stresses given in [7.1] are applicable for normal strength hull structural steel. When higher strength hull structural steels are used, higher values may be used which will be determined in each individual case.

## 1.5 Definitions

- $C_R$  = rudder force [kN]
- $Q_R$  = rudder torque [kNm]
- $A$  = total movable area of rudder [m<sup>2</sup>]
- $A_t$  =  $A$  + area of a rudder horn, if any [m<sup>2</sup>]

- $A_f$  = portion of rudder area located ahead of the rudder stock axis [m<sup>2</sup>]  
 $b$  = mean height of rudder area [m]  
 $c$  = mean breadth of rudder area [m], see Figure 1.

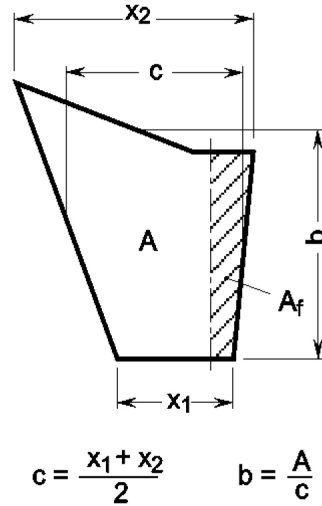

**Figure 1 Rudder area**

- $\Lambda$  = aspect ratio of rudder area  $A_t$   

$$\Lambda = \frac{b^2}{A_t}$$
- $v_0$  = ahead speed of the yacht in [kn]  
 if this speed is less than 10 kn,  $v_0$  shall be taken as  

$$v_{\min} = \frac{v_0 + 20}{3} \text{ [kn]}$$
- $v_a$  = astern speed of the yacht in [kn]; if the astern speed  $v_a$  is less than 0.4  $v_0$  or 6 kn, whichever is less, determination of rudder force and torque for astern condition is not required. For greater astern speeds special evaluation of rudder force and torque as a function of rudder angle may be required. If no limitation for the rudder angle at astern condition is stipulated, the factor  $\kappa_2$  shall not be taken less than given in Table 1 for astern condition.

## 2 Rudder force and torque

### 2.1 Rudder force and torque for normal rudders

**2.1.1** The rudder force shall be determined according to the following equation:

$$C_R = 0.132 \cdot A \cdot v^2 \cdot \kappa_1 \cdot \kappa_2 \cdot \kappa_3 [\text{kN}]$$

where:

- $v$  =  $v_0$  for ahead condition

- $\kappa_1$  =  $v_a$  for astern condition  
 = coefficient, depending on the aspect ratio  $\Lambda$   
 =  $(\Lambda + 2)/3$ , where  $\Lambda$  need not be taken greater than 2  
 $\kappa_2$  = coefficient, depending on type of rudder and rudder profile according to [Table 1](#)  
 $\kappa_3$  = coefficient, depending on location of the rudder  
 = 0.8 for rudders outside propeller jet  
 = 1.0 elsewhere, including also rudders within propeller jet.

**Table 1 Coefficient  $\kappa_2$  for different types of rudder profiles**

| Profile/type of rudder               | $\kappa_2$ |        |
|--------------------------------------|------------|--------|
|                                      | ahead      | astern |
| NACA-00 series<br>Göttingen profiles | 1.1        | 1.4    |
| flat side profiles                   | 1.1        | 1.4    |
| mixed profiles (e.g. HSVA)           | 1.21       | 1.4    |

**2.1.2** The rudder torque shall be determined by the following equation:

$$Q_R = C_R \cdot r \text{ [kNm]}$$

where:

- $r$  =  $c \cdot (\alpha - k_b)$  [m]  
 $\alpha$  = 0.33 for ahead condition  
 = 0.66 for astern condition (general)  
 = 0.75 for astern condition (hollow profiles).

For parts of a rudder behind a fixed structure such as a rudder horn:

- $\alpha$  = 0.25 for ahead condition  
 = 0.55 for astern condition.

For high lift rudders  $\alpha$  shall be specially considered. If not known,  $\alpha = 0.40$  may be used for ahead condition

$k_b$  = balance factor as follows:

$$k_b = \frac{A_f}{A}$$

$k_b = 0.08$  for unbalanced rudders

$r_{min}$  =  $0.1 \cdot c$  [m] for ahead condition.

**2.1.3** Effects of the provided type of rudder/profile on choice and operation of the steering gear shall be observed.

## 2.2 Rudder force and torque for rudder blades with cut-outs (semi-spade rudders)

**2.2.1** The total rudder force  $C_R$  shall be calculated according to [2.1.1]. The pressure distribution over the rudder area, upon which determination of rudder torque and rudder blade strength shall be based, shall be derived as follows:

The rudder area may be divided into two rectangular or trapezoidal parts with areas  $A_1$  and  $A_2$ , see Figure 2. The resulting force of each part may be taken as:

$$C_{R1} = C_R \cdot \frac{A_1}{A} \text{ [kN]}$$

$$C_{R2} = C_R \cdot \frac{A_2}{A} \text{ [kN]}$$

**2.2.2** The resulting torque of each part may be taken as:

$$Q_{R1} = C_{R1} \cdot r_1 \text{ [kNm]}$$

$$Q_{R2} = C_{R2} \cdot r_2 \text{ [kNm]}$$

$$r_1 = c_1 \cdot (\alpha - k_{b1}) \text{ [m]}$$

$$r_2 = c_2 \cdot (\alpha - k_{b2}) \text{ [m]}$$

$$k_{b1} = \frac{A_{1f}}{A_1}$$

$$k_{b2} = \frac{A_{2f}}{A_2}$$

$A_{1f}, A_{2f}$  see Figure 2

$$c_1 = \frac{A_1}{b_1}$$

$$c_2 = \frac{A_2}{b_2}$$

where:

$b_1, b_2$  = mean heights of partial rudder areas  $A_1$  and  $A_2$ , see Figure 2.

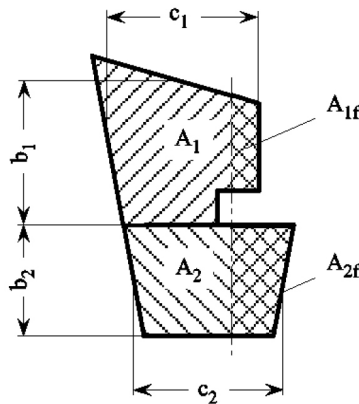

**Figure 2 Rudder areas**

**2.2.3** The total rudder torque shall be determined according to the following equations:

$$Q_R = Q_{R1} + Q_{R2} \text{ [kNm]}$$

$$Q_{Rmin} = C_R \cdot r_{1.2min} \text{ [kNm]}$$

$$r_{1.2min} = \frac{0.1}{A} \cdot (c_1 \cdot A_1 + c_2 \cdot A_2) \text{ [m]}$$

For ahead condition the rudder torque ( $Q_R$ ) shall not be less than  $Q_{Rmin}$ .

## 3 Scantlings of the rudder stock

### 3.1 Rudder stock diameter

**3.1.1** The diameter of the rudder stock for transmitting the rudder torque shall not be less than:

$$D_t = 260 \cdot \sqrt[3]{\frac{Q_R}{f_m \cdot R_{eH}}} \text{ [mm]}$$

where:

$Q_R$  = see [2.1.2], [2.2.2] and [2.2.3].

The related torsional stress is:

$$\tau_t = \frac{f_m R_{eH}}{\sqrt{3} \gamma_m \gamma} \text{ [MPa]}$$

where:

$\gamma$  = 1.8

$\gamma_m$  = 1.1

**3.1.2** The diameter of the rudder stock determined according to [3.1.1] is decisive for steering gear, stopper and locking device.

**3.1.3** In case of mechanical steering gear, the diameter of the rudder stock in its upper part, which is only intended for transmission of the torsional moment from the auxiliary steering gear may be  $0.9 D_t$ . The length of the edge of the quadrangle for the auxiliary tiller shall not be less than  $0.77 D_t$  and the height not less than  $0.8 D_t$ .

**3.1.4** The rudder stock shall be secured against axial sliding. The degree of the permissible axial clearance depends on the construction of steering engine and bearing.

## 3.2 Strengthening of rudder stock

**3.2.1** If the rudder is so arranged that additional bending stresses occur in the rudder stock, the stock diameter has to be suitably increased. The increased diameter is, where applicable, decisive for the scantlings of the coupling.

For the increased rudder stock diameter the equivalent stress of bending and torsion shall not exceed the following value:

$$\sigma_v = \sqrt{\sigma_b^2 + 3 \cdot \tau^2} \leq \frac{f_m R_{eH}}{\gamma_m \gamma} \text{ [MPa]}$$

where:

$$\gamma = 1.8$$

$$\gamma_m = 1.1$$

Bending stress:

$$\sigma_b = \frac{10.2 \cdot M_b}{D_1^3} \text{ [MPa]}$$

where:

$M_b$  = bending moment at the neck bearing [kNm].

Torsional stress:

$$\tau = \frac{5.1 \cdot Q_R}{D_1^3} \text{ [MPa]}$$

where:

$D_1$  = increased rudder stock diameter [mm].

The increased rudder stock diameter may be determined by the following equation:

$$D_1 = 0.1 \cdot D_t \cdot \sqrt[6]{1 + \frac{4}{3} \cdot \left(\frac{M_b}{Q_R}\right)^2}$$

where:

$Q_R$  = see [2.1.2], [2.2.2] and [2.2.3]

$D_t$  = see [3.1.1].

**Note:**

Where a double-piston steering gear is fitted, additional bending moments may be transmitted from the steering gear into the rudder stock. These additional bending moments shall be taken into account for determining the rudder stock diameter.

---e-n-d---o-f---n-o-t-e---

## 3.3 Analysis

### 3.3.1 General

The evaluation of bending moments, shear forces and support forces for the system rudder - rudder stock may be carried out for some basic rudder types as shown in Figure 3 to Figure 5 as outlined in [3.3.2] to [3.3.3].

### 3.3.2 Data for the analysis

$\ell_{10} - \ell_{50}$  = lengths of the individual girders of the system [m]

$I_{10} - I_{50}$  = moments of inertia of these girders [cm<sup>4</sup>].

For rudders supported by a sole piece, the length  $\ell_{20}$  is the distance between lower edge of rudder body and centre of sole piece, and  $I_{20}$  is the moment of inertia of the pintle in the sole piece.

Load on rudder body (general):

$$P_R = \frac{C_R}{\ell_{10} \cdot 10^3} \text{ [kN/m]}$$

Load on semi-spade rudders:

$$P_{R10} = \frac{C_{R2}}{\ell_{10} \cdot 10^3} \text{ [kN/m]}$$

$$P_{R20} = \frac{C_{R1}}{\ell_{10} \cdot 10^3} \text{ [kN/m]}$$

$C_R, C_{R1}, C_{R2}$  = see [2.1.1] and [2.2.1]

$Z$  = spring constant of support in the sole piece or rudder horn respectively for support in the sole piece (Figure 3):

$$Z = \frac{6.18 \cdot I_{50}}{\ell_{50}^3} \text{ [kNm]}$$

for support in the rudder horn (Figure 4):

$$Z = \frac{1}{f_b + f_t} \text{ [kNm]}$$

$f_b$  = unit displacement of rudder horn [m] due to a unit force of 1 kN acting in the centre of support

$$f_b = 0.21 \cdot \frac{d^3}{I_n} \text{ [m/kN]} \text{ (guidance value for steel)}$$

$I_n$  = moment of inertia of rudder horn around the x-axis at  $d/2$  [cm<sup>4</sup>], see also Figure 4

$f_t$  = unit displacement due to a torsional moment of the amount 1 e [kNm]

$$f_t = \frac{d \cdot e^2}{G \cdot J_t}$$

$$f_t = \frac{d \cdot e^2 \cdot \sum u_i / t_i}{3.14 \cdot 10^8 \cdot A} \text{ [m/kN] for steel}$$

- $J_t$  = torsional moment of inertia [m<sup>4</sup>]
- $A_T$  = mean sectional area of rudder horn [m<sup>2</sup>]
- $u_i$  = breadth [mm] of individual plates forming the mean horn sectional area
- $t_i$  = plate thickness within individual breadth  $u_i$  [mm]
- $e, d$  = distances [m] according to Figure 4.

### 3.3.3 Moments and forces to be evaluated

The bending moment  $M_R$  and the shear force  $Q_1$  in the rudder body, the bending moment  $M_b$  in the neck bearing and the support forces  $B_1, B_2, B_3$  shall be evaluated.

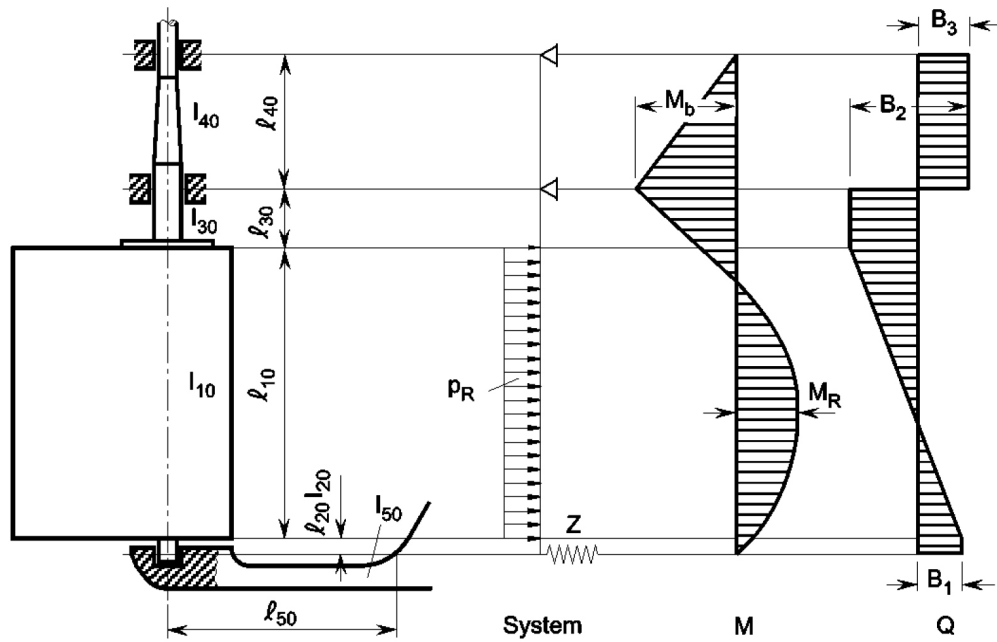

**Figure 3 Rudder supported by sole piece**

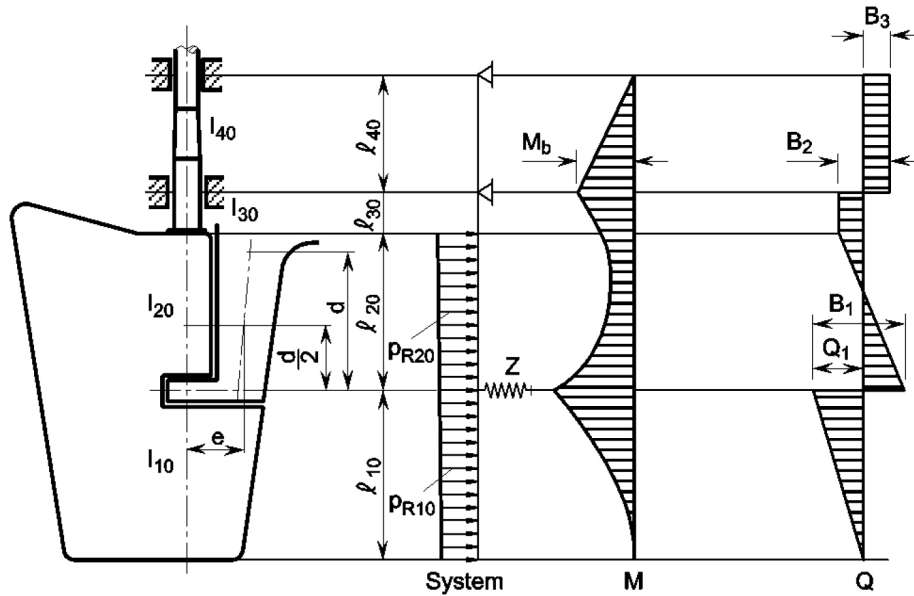

Figure 4 Semi-spade rudder

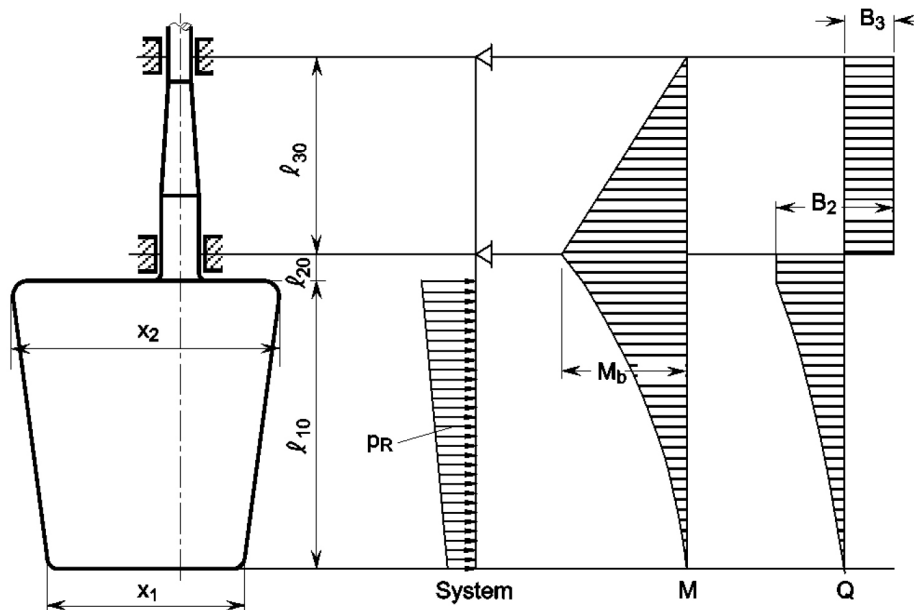

Figure 5 Spade rudder

The so evaluated moments and forces shall be used for the stress analyses required by [3.2] and [5.1] and for calculation of sole piece and rudder horn.

For spade rudders moments and forces may be determined by the following formulae:

$$M_b = C_R \cdot \left( \ell_{20} + \frac{\ell_{10} \cdot (2 \cdot x_1 + x_1)}{3 \cdot (x_1 + x_2)} \right) \text{ [kNm]}$$

$$B_3 = \frac{M_b}{\ell_{30}} \text{ [kN]}$$

$$B_2 = C_R + B_3 \text{ [kN]}$$

### 3.4 Rudder trunk

Where the rudder stock is arranged in a trunk in such a way that the trunk is stressed by forces due to rudder action, the scantlings of the trunk shall be such that the equivalent stress due to bending and shear does not exceed  $0.35 \cdot f_m R_{eH}$  of the material used.

## 4 Sole piece

### 4.1

The section modulus of the sole piece related to z-axis shall not be less than:

$$W_z = \frac{1000 \cdot B_1 \cdot x}{0.35 \cdot f_m R_{eH}} \text{ [cm}^3\text{]}$$

where:

$B_1 = \text{see [5.1]}$ .

For rudders with two supports the support force is approximately  $B_1 = C_R/2$ , when the elasticity of the sole piece is ignored.

$x$  = distance of the respective cross section from the rudder axis [m]

$x_{min}$  =  $0.5 \cdot \ell_{50}$

$x_{max}$  =  $\ell_{50}$

$\ell_{50}$  = see [Figure 6](#).

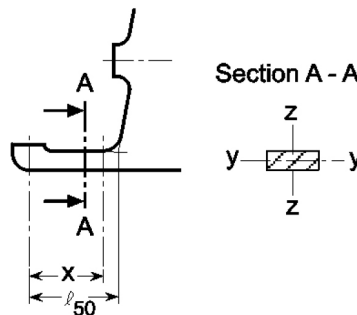

**Figure 6 Sole piece parameters**

## 4.2

The section modulus related to y-axis shall not be less than:

- where no rudder post or rudder axle is fitted:

$$W_y = \frac{W_z}{2}$$

- where a rudder post or rudder axle is fitted:

$$W_y = \frac{W_z}{3}$$

## 4.3

The sectional area at the location  $x = \lambda_{50}$  shall not be less than:

$$A_s = \frac{1000 \cdot B_1 \sqrt{3}}{0.35 \cdot f_m R_{eH}} \text{ [mm}^2\text{]}$$

## 4.4

The equivalent stress taking into account bending and shear stresses at any location within length  $\lambda_{50}$  shall not exceed:

$$\sigma_v = \sqrt{\sigma_b^2 + 3 \cdot \tau^2} \leq 0.5 \cdot f_m R_{eH} \text{ [MPa]}$$

$$\sigma_b = \frac{1000 \cdot B_1 \cdot x}{W_z} \text{ [MPa]}$$

$$\tau = \frac{1000 \cdot B_1}{A_s} \text{ [MPa]}$$

# 5 Rudder horn of semi spade rudders

## 5.1

The distribution of the bending moment, shear force and torsional moment shall be determined according to the following equations:

- bending moment:  $M_b = B_1 z$  [kNm]

$$M_{b\max} = B_1 d \text{ [kNm]}$$

- shear force:  $Q = B_1$  [kN]

- torsional moment:  $M_T = B_1 e(z)$  [kNm]

For determining preliminary scantlings flexibility of the rudder horn may be ignored and the supporting force  $B_1$  be calculated according to the following equation:

$$B_1 = C_R \cdot \frac{b}{c} \text{ [kN]}$$

$b$ ,  $c$ ,  $d$ ,  $e(z)$  and  $z$  see [Figure 7](#) and [Figure 8](#).

$b$  = results from position of the centre of gravity of the rudder area.

## 5.2

The section modulus of the rudder horn in transverse direction related to the horizontal x-axis shall at any location  $z$  not be less than:

$$W_x = \frac{3500 \cdot M_b}{f_m R_{eH}} [\text{cm}^3]$$

## 5.3

At no cross section of the rudder horn the shear stress due to the shear force  $Q$  shall exceed the value:

$$\tau = 0,35 \cdot f_m R_{eH} [\text{MPa}]$$

The shear stress shall be determined by following equation:

$$\tau = \frac{1000 \cdot B_1}{A_h} [\text{MPa}]$$

$A_h$  = effective shear area of rudder horn in y-direction [ $\text{mm}^2$ ].

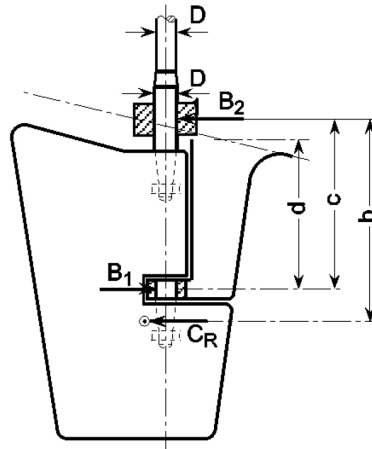

**Figure 7 Parameters for semi spade rudders**

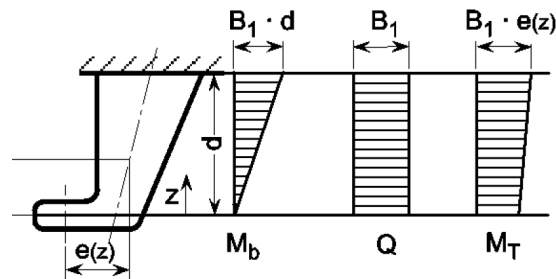

**Figure 8 Forces on rudder horn**

## 5.4

The equivalent stress at any location ( $z$ ) of the rudder horn shall not exceed following value:

$$\sigma_v = \sqrt{\sigma_b^2 + 3 \cdot (\tau^2 + \tau_T^2)} = 0.5 \cdot f_m R_{eH} \text{ [MPa]}$$

$$\sigma_b = \frac{1000 \cdot M_b}{W_x} \text{ [MPa]}$$

$$\tau_T = \frac{M_T}{2 \cdot A_T \cdot t_h} \text{ [MPa]}$$

where:

$A_T$  = sectional area [ $\text{m}^2$ ] surrounded by the rudder horn at the location examined

$t_h$  = thickness of rudder horn plating in [mm].

## 5.5

When determining the thickness of rudder horns plating the provisions of [5.2] to [5.4] shall be complied with. The thickness shall, however, not be less than:

$$t_{\min} = 36.8 \cdot \sqrt{\frac{L}{f_m R_{eH}}} \text{ [mm]}$$

## 5.6

The rudder horn plating shall be effectively connected to the aft ship structure, e.g. by connecting the plating to longitudinal girders, in order to achieve a proper transmission of forces, see [Figure 9](#).

## 5.7

Transverse webs of the rudder horn shall be led into the hull up to the next deck in a sufficient number and shall be of adequate thickness.

## 5.8

Strengthened plate floors shall be fitted in line with transverse webs in order to achieve a sufficient connection with the hull structure. The thickness of these plate floors shall be increased by 50 per cent above the rule values as required by [Ch.4 Sec.3](#)

## 5.9

The centre line bulkhead (wash-bulkhead) in the afterpeak shall be connected to the rudder horn.

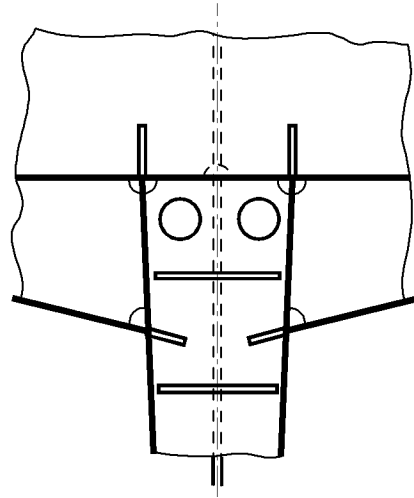

**Figure 9 Connection of rudder horn to the aft ship structure**

## 5.10

Where the transition between rudder horn and shell is curved, about 50% of the required total section modulus of the rudder horn shall be formed by webs in a section A - A located in the centre of the transition zone, i.e.  $0.7 r$  above beginning of the transition zone, see Figure 10.

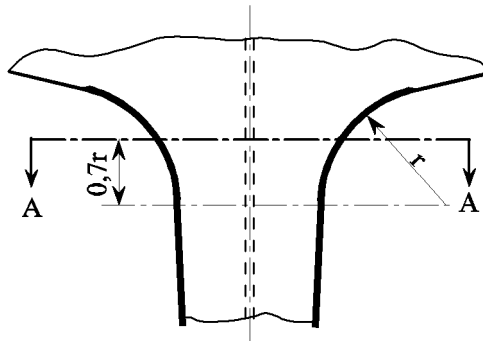

**Figure 10 Transition between rudder horn and curved shell**

## 6 Rudder couplings

### 6.1 General

**6.1.1** Couplings shall be designed in such a way as to enable them to transmit the full torque of the rudder stock.

**6.1.2** The distance of bolt axis from the edges of the flange shall not be less than 1.2 the diameter of the bolt. In horizontal couplings, at least 2 bolts shall be arranged forward of the rudder stock axis.

**6.1.3** Coupling bolts shall be fitted bolts. Bolts and nuts shall be effectively secured against loosening.

**6.1.4** For spade rudders horizontal couplings according to [6.2] are permissible only where the required thickness of the coupling flanges  $t_f$  is less than 50 mm, otherwise cone couplings according to [6.3] shall be applied. For spade rudders of the high lift type, only cone couplings according to [6.3] are permitted.

## 6.2 Horizontal couplings

**6.2.1** The diameter of coupling bolts shall not be less than:

$$d_b = 0.62 \cdot \sqrt{\frac{D^3 \cdot (f_m R_{eH})_r}{(f_m R_{eH})_b \cdot n \cdot e}} \text{ [mm]}$$

where:

- $D$  = rudder stock diameter according to 3 [mm]
- $n$  = total number of bolts, which shall not be less than 6
- $e$  = mean distance of bolt axes from centre of bolt system [mm]
- $r$  = index for the rudder stock material
- $b$  = index for bolts material.

**6.2.2** The thickness of the coupling flanges shall not be less than determined by the following equation:

$$t_f = 0.62 \cdot \sqrt{\frac{D^3 \cdot (f_m R_{eH})_r}{(f_m R_{eH})_f \cdot n \cdot e}} \text{ [mm]}$$

where:

- $t_{fmin}$  =  $0.9 d_b$
- $f$  = index for the coupling flanges material.

The thickness of the coupling flanges clear of the bolt holes shall not be less than  $0.65 t_f$ .

The width of material outside the bolt holes shall not be less than  $0.67 d_b$ .

**6.2.3** Coupling flanges shall be equipped with a fitted key according to DIN 6885 or equivalent standard for relieving the bolts.

The fitted key may be dispensed with if the diameter of the bolts is increased by 10%.

**6.2.4** Horizontal coupling flanges shall either be forged together with the rudder stock or be welded to the rudder stock as outlined in the rules [Ch.4 App.C \[2.4.4\]](#).

**6.2.5** For the connection of the coupling flanges with the rudder body see also [Ch.4 App.C \[2.4\]](#).

## 6.3 Cone couplings

### 6.3.1 Cone couplings with key

Cone couplings shall have a taper  $C$  on diameter of 1 : 8 - 1 : 12.

$C = (d_0 - d_u)/\ell$  according to [Figure 11](#).

The cone shape shall be very exact. The nut shall be carefully secured, e.g. by a securing plate as shown in Figure 11.

The coupling length  $\lambda$  shall, in general, not be less than  $1.5 d_0$ .

For couplings between stock and rudder a key shall be provided, the shear area of which shall not be less than:

$$a_s = \frac{160 \cdot Q_F}{d_k \cdot R_{eH1}} \text{ [mm}^2\text{]}$$

where:

- $Q_F$  = design yield moment of rudder stock [kNm] according to [8]
- $d_k$  = diameter of the conical part of rudder stock [mm] at the key
- $R_{eH1}$  = minimum nominal upper yield point of key material, in MPa.

The effective surface area of the key (without rounded edges) between key and rudder stock or cone coupling shall not be less than:

$$a_k = \frac{50 \cdot Q_F}{d_k \cdot R_{eH2}} \text{ [mm}^2\text{]}$$

where:

- $R_{eH2}$  = minimum nominal upper yield point of key, stock or coupling material in MPa, whichever is less.

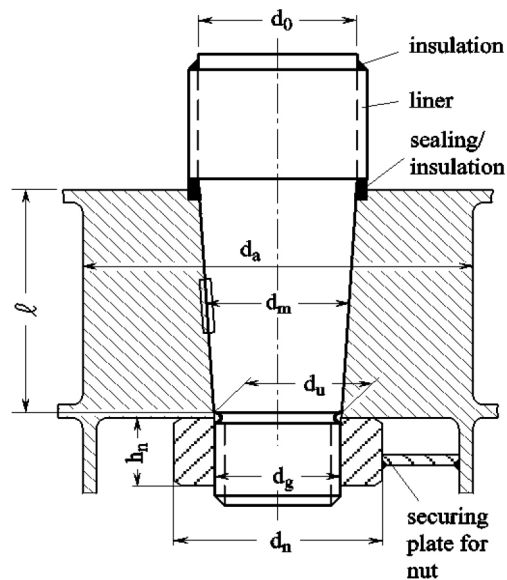

**Figure 11 Cone coupling**

The dimensions of the slugging nut shall be as follows:

– height:

$$h_n = 0.6 \cdot d_g$$

– outer diameter (the greater value to be taken):

$$d_n = 1.2 \cdot d_u \quad \text{or} \quad d_n = 1.5 \cdot d_g$$

– external thread diameter:

$$d_g = 0.65 \cdot d_0$$

See [Figure 11](#).

It shall be proved that 50% of the design yield moment will be solely transmitted by friction in the cone couplings. This can be done by calculating the required push-up pressure and push-up length for a torsional moment  $Q'_F = 0.5 Q_F$ .

### 6.3.2 Cone couplings with special arrangements for mounting and dismounting of couplings

Where the stock diameter exceeds 200 mm the press fit is recommended to be effected by a hydraulic pressure connection. In such cases the cone should be more slender,  $C \approx 1 : 12$  to  $\approx 1 : 20$ .

In case of hydraulic pressure connections the nut shall be effectively secured against the rudder stock or the pintle. A securing plate for securing the nut against the rudder body shall not be provided, see [Figure 12](#).

#### Note:

A securing flat bar will be regarded as an effective securing device of the nut, if its shear area is not less than:

$$A_s = \frac{1000 \cdot P_s \cdot \sqrt{3}}{R_{eH}} \quad [\text{mm}^2]$$

where:

$P_s$  = shear force as follows

$$P_s = \frac{P_e}{2} \cdot \mu \cdot \left( \frac{d_1}{d_g} - 0.6 \right) [\text{kN}]$$

$P_e$  = push-up force in [kN] according to push-up pressure  $p_{reg1}$  and  $p_{reg2}$

$\mu_1$  = frictional coefficient between nut and rudder body, normally  $\mu_1 = 0.3$

$d_1$  = mean diameter of frictional area between nut and rudder body

$d_g$  = thread diameter of nut

$R_{eH}$  = yield point in MPa of securing flat bar material.

---e-n-d---o-f---n-o-t-e---

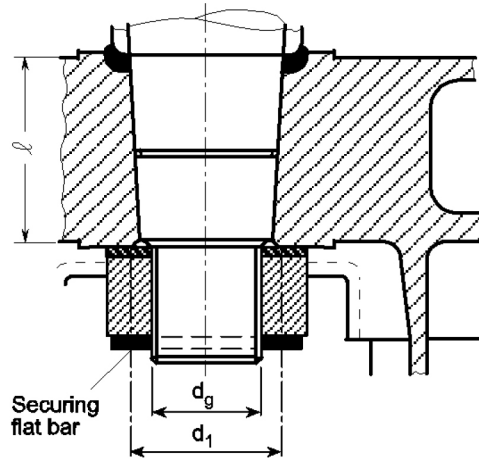

**Figure 12 Cone coupling with special arrangements for mounting and dismounting**

For safe transmission of the torsional moment by the coupling between rudder stock and rudder body the push-up length and the push-up pressure shall be determined by following equations.

*Push-up pressure*

The push-up pressure shall not be less than the greater of the two following values:

$$P_{req1} = \frac{2 \cdot Q_F \cdot 10^6}{d_m^2 \cdot \ell \cdot \pi \cdot \mu_0} \text{ [MPa]}$$

or

$$P_{req2} = \frac{6 \cdot M_b \cdot 10^6}{\ell^2 \cdot d_m} \text{ [MPa]}$$

where:

- $Q_F$  = design yield moment of rudder stock according to 8 in kNm
- $d_m$  = mean cone diameter [mm]
- $\ell$  = cone length [mm]
- $\mu_0$  = 0.15 (frictional coefficient)
- $M_b$  = bending moment in cone coupling (e.g. in case of spade rudders) [kNm].

It has to be proved that the push-up pressure does not exceed the permissible surface pressure in the cone. The permissible surface pressure shall be determined by following equation:

$$P_{perm} = \frac{0.8 \cdot R_{eH} \cdot (1 - \alpha^2)}{\sqrt{3 + \alpha^4}}$$

where:

$R_{eH}$  = yield point in MPa of the material of the gudgeon

$\alpha = \frac{d_m}{d_a}$  see [Figure 11](#).

The outer diameter of the gudgeon should not be less than:

$$d_a = 1.5 \cdot d_m \text{ [mm]}$$

*Push-up length*

The push-up length shall not be less than:

$$\Delta \ell_1 = \frac{P_{req} \cdot d_m}{E \cdot \left(\frac{1-\alpha^2}{2}\right) \cdot c} + \frac{0.8 \cdot R_{tm}}{c} \text{ [mm]}$$

where:

$R_{tm}$  = mean roughness [mm]

$R_{tm} \approx 0.01 \text{ mm}$

$c$  = taper on diameter according to [\[6.3.2\]](#).

The push-up length is, however, not to be taken greater than:

$$\Delta \ell_2 = \frac{1.6 \cdot R_{eh} \cdot d_m}{\sqrt{3 + \alpha^4} \cdot E \cdot c} + \frac{0.8 \cdot R_m}{c} \text{ [mm]}$$

**Note:**

In case of hydraulic pressure connections the required push-up force  $P_e$  for the cone may be determined by the following equation:

$$P_e = \frac{1}{1000} P_{req} \cdot d_m \cdot \pi \cdot \ell \cdot \left(\frac{c}{2} + 0.02\right) \text{ [kN]}$$

Where due to the fitting procedure a partial push-up effect caused by the rudder weight is given, this may be taken into account when fixing the required push-up length, subject to approval by the Society.

---e-n-d---o-f---n-o-t-e---

The required push-up pressure for pintle bearings shall be determined by following equation:

$$p_{req} = 400 \cdot \frac{B_\ell \cdot d_0}{d_m^2 \cdot \ell} \text{ [MPa]}$$

where:

$B_1$  = supporting force in pintle bearing [kN], see also [Figure 4](#)

$d_m, \ell$  = see [\[6.3.2\]](#)

$d_0$  = pintle diameter [mm] according to [Figure 11](#).

## 7 Rudder body, rudder bearings

### 7.1 Strength of rudder body

**7.1.1** The rudder body shall be stiffened by horizontal and vertical webs in such a manner that the rudder body will be effective as a beam. The rudder should be additionally stiffened at the aft edge.

**7.1.2** The strength of the rudder body shall be proved by direct calculation according to [3.3.2].

**7.1.3** For rudder bodies without cut-outs the permissible stress is limited to:

bending stress due to  $M_R$ :

$$\sigma_b = 110 \text{ [MPa]}$$

shear stress due to  $Q_1$ :

$$\tau = 50 \text{ [MPa]}$$

equivalent stress due to bending and shear:

$$\sigma_v = \sqrt{\sigma_b^2 + 3 \cdot \tau^2} = 120 \text{ [MPa]}$$

$M_R$ ,  $Q_1$  see [3.3.3] and Figure 3 and Figure 4.

In case of openings in the rudder plating for access to cone coupling or pintle nut the permissible stresses according to [7.1.4] apply. Smaller permissible stress values may be required if the corner radii are less than  $0.15 h_0$ , where  $h_0$  = height of opening.

**7.1.4** In rudder bodies with cut-outs (semi-spade rudders) the following stress values shall not be exceeded:

bending stress due to  $M_R$ :

$$\sigma_b = 90 \text{ [MPa]}$$

shear stress due to  $Q_1$ :

$$\tau = 50 \text{ [MPa]}$$

torsional stress due to  $M_t$ :

$$\tau_t = 50 \text{ [MPa]}$$

equivalent stress due to bending and shear and equivalent stress due to bending and torsion:

$$\sigma_{v1} = \sqrt{\sigma_b^2 + 3 \cdot \tau^2} = 120 \text{ [MPa]}$$

$$\sigma_{v2} = \sqrt{\sigma_b^2 + 3 \cdot \tau^2} = 120 \text{ [MPa]}$$

$$M_R = C_R \cdot f_1 + B_1 \cdot \frac{f_2}{2} \text{ [kNm]}$$

where:

$$Q_1 = C_{R2} \text{ [kN]}$$

$$f_1, f_2 = \text{see Figure 13 [m].}$$

The torsional stress may be calculated in a simplified manner as follows:

$$\tau_t = \frac{M_t}{2 \cdot \ell \cdot h \cdot t} \text{ [MPa]}$$

where:

$$M_t = C_{R2} e \text{ [kNm]}$$

$C_{R2}$  = partial rudder force [kN] of the partial rudder area  $A_2$  below the cross section under consideration

$e$  = lever for torsional moment [m]

(Horizontal distance between the centroid of area  $A_2$  and centre line a-a of the effective cross sectional area under consideration, see Figure 13. The centroid shall be assumed at  $0.33 c_2$  aft of the forward edge of area  $A_2$ , where  $c_2$  = mean breadth of area  $A_2$ ).

$h, \ell, t$  = in [mm], see Figure 13.

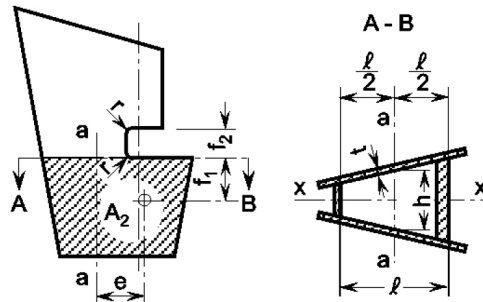

**Figure 13 Rudder body**

The distance  $\ell$  between vertical webs should not exceed  $1.2 h$ .

The radii in the rudder plating shall not be less than 4 – 5 times the plate thickness, but in no case less than 50 mm.

**Note:**

It is recommended to keep the natural frequency of the fully immersed rudder and of local structural components at least 10% above the exciting frequency of the propeller (number of revolutions  $\times$  number of blades) or if relevant above higher order.

---e-n-d---o-f---n-o-t-e---

## 7.2 Rudder plating

**7.2.1** The thickness of rudder plating shall be determined according to following equation:

$$t = 26.7 \cdot a \cdot \sqrt{\left( \frac{p_R}{(f_m R_{eH})} \right)} + 2.5 \text{ [mm]}$$

where:

$a$  = smaller unsupported width of a plate panel [m].

$$P_R = 10 \cdot T + \frac{C_R}{A} [\text{kPa}]$$

The influence of the aspect ratio of the plate panels may be taken into account.

The thickness shall, however, not be less than  $t_{\min}$  according to [Ch.4 Sec.4 \[4.1\]](#) for the bottom shell plating.

**7.2.2** For connecting the side plating of the rudder to the webs tenon welding shall not be used. Where application of fillet welding is not practicable, the side plating shall be connected by means of slot welding to flat bars which are welded to the webs.

**7.2.3** The thickness of the webs shall not be less than 70% of the thickness of the rudder plating according to [\[7.2.1\]](#), but not less than:

$$t_{\min} = \frac{120}{\sqrt{(f_m R_{eH})}} [\text{mm}]$$

Webs exposed to seawater shall be dimensioned according to [\[7.2.1\]](#).

## 7.3 Transmitting of rudder torque

**7.3.1** For transmitting the rudder torque, the rudder plating according to [\[7.2.1\]](#) shall be increased by 25% in way of the coupling. A sufficient number of vertical webs shall be fitted in way of the coupling.

**7.3.2** If the torque is transmitted by a prolonged shaft extended into the rudder, the latter shall have the diameter  $D_t$  or  $D_1$ , whichever is greater, at the upper 10% of the intersection length. Downwards it may be tapered to 0.6  $D_t$ , in spade rudders to 0.4 times the strengthened diameter, if sufficient support is provided for.

## 7.4 Rudder bearings

**7.4.1** In way of bearings liners and bushes shall be fitted. Where in case of small ships bushes are not fitted, the rudder stock shall be suitably increased in diameter in way of bearings enabling the stock to be re-machined later.

**7.4.2** An adequate lubrication shall be provided.

**7.4.3** The bearing forces result from the direct calculation mentioned in [\[3.3\]](#). As a first approximation the bearing force may be determined without taking account of the elastic supports. This can be done as follows:

— normal rudder with two supports:

the rudder force  $C_R$  shall be distributed to the supports according to their vertical distances from the centre of gravity of the rudder area.

— semi-spade rudders:

— support force in the rudder horn:

$$B_1 = C_R \cdot \frac{b}{c} [\text{kN}]$$

— support force in the neck bearing:

$$B_2 = C_R - B_1 [\text{kN}]$$

For  $b$  and  $c$  see [Figure 7](#).

**7.4.4** The projected bearing surface  $A_b$  (bearing height × external diameter of liner) shall not be less than:

$$A_b = \frac{1000 \cdot B}{q} \text{ [mm}^2\text{]}$$

where:

- $B$  = support force [kN]  
 $q$  = permissible surface pressure according to [Table 2](#).

**7.4.5** Stainless and wear resistant steels, bronze and hot-pressed bronze-graphite materials have a considerable difference in potential to non-alloyed steel. Respective preventive measures are required.

**7.4.6** The bearing height shall be equal to bearing diameter, however, shall not exceed 1.2 times the bearing diameter. Where bearing depth is less than bearing diameter, higher specific surface pressures may be allowed.

**7.4.7** The wall thickness of pintle bearings in sole piece and rudder horn shall be approximately  $\frac{1}{4}$  of pintle diameter.

**Table 2 Permissible surface pressure for bearing materials**

| Bearing material   | $q$ [MPa] |
|--|-----------|
| Lignum vitae   | 2.5       |
| White metal, oil lubricated                                | 4.5       |
| Synthetic material 1)                                      | 5.5       |
| Steel 2), bronze and hot-pressed bronze-graphite materials | 7.0       |

1) Synthetic materials to be of approved type.  
 Surface pressures exceeding 5.5 MPa may be accepted in accordance with bearing manufacturer's specification and tests, but in no case more than 10 MPa.

2) Stainless and wear resistant steel in an approved combination with stock liner. Higher surface pressures than 7 MPa may be accepted if verified by tests.

## 7.5 Pintles

**7.5.1** Pintles shall have scantlings complying with conditions given in [\[7.4.4\]](#) and [\[7.4.6\]](#). The pintle diameter shall not be less than:

$$d = 170 \cdot \sqrt{\left(\frac{B_1}{(f_m R_{eH})}\right)} \text{ [mm]}$$

where:

- $B_1$  = support force [kN]

**7.5.2** The thickness of any liner or bush shall not be less than:

$$t = 0.316 \cdot \sqrt{B_1} \text{ [mm]}$$

$t_{min}$  = 8 mm for metallic materials and synthetic material  
= 22 mm for lignum material.

**7.5.3** Where pintles are of conical shape, they shall comply with the following:

|                   |  |
|-------------------|--|
| taper on diameter | 1 : 8 to 1 : 12                                  |
|                   | if keyed by slugging nut                         |
| taper on diameter | 1 : 12 to 1 : 20                                 |
|                   | if mounted with oil injection and hydraulic nut. |

**7.5.4** Pintles shall be arranged in such a manner as to prevent unintentional loosening and falling out. For nuts and threads the requirements of [6.3.1] and [6.3.2] apply accordingly.

## 7.6 Bearing clearances

**Guidance note:**

For metallic bearing material the bearing clearance should generally not be less than:

$$\frac{d_b}{1000} + 1.0 \text{ [mm]}$$

where:

$d_b$  = inner diameter of bush [mm].

If non-metallic bearing material is applied, the bearing clearance shall be specially determined considering the material's swelling and thermal expansion properties.

Clearance is in no way to be taken less than 1.5 mm on diameter. In case of self-lubricating bushes going down below this value may be agreed to on the basis of the manufacturer's specification.

---e-n-d---o-f---g-u-i-d-a-n-c-e---o-t-e---

## 8 Design yield moment of rudder stock

The design yield moment of the rudder stock shall be determined by the following equation:

$$Q_F = 0.1134 \cdot 10^6 \cdot f_m R_{eH} D_t^3 \text{ [kNm]}$$

where:

$D_t$  = stock diameter [mm] according to [3.1].

Where the actual diameter  $D_{ta}$  is greater than the calculated diameter  $D_t$ , diameter  $D_{ta}$  shall be used. However,  $D_{ta}$  need not be taken greater than 1.145  $D_t$ .

## 9 Stopper, locking device

### 9.1 Stopper

The motions of quadrants or tillers shall be limited on either side by stoppers. The stoppers and their foundations connected to the ship's hull shall be of strong construction so that the yield point of the applied materials is not exceeded at the design yield moment of the rudder stock.

### 9.2 Locking device

Each steering gear shall be provided with a locking device in order to keep the rudder fixed at any position. This device as well as the foundation in the ship's hull shall be of strong construction so that the yield point of the applied materials is not exceeding the design yield moment of the rudder stock as specified in [8]. Where the ship's speed exceeds 12 knots, the design yield moment need only be calculated for a stock diameter based on a speed  $v_0 = 12$  kn.

## SECTION 3 COMPOSITE RUDDERS

### 1 General

#### 1.1 Manoeuvring arrangement

**1.1.1** Yachts shall be provided with a manoeuvring arrangement which will guarantee sufficient manoeuvring capability.

**1.1.2** The manoeuvring arrangement includes all parts, from the rudder and steering gear to the steering position necessary for steering of yachts.

**1.1.3** Rudder stock, rudder coupling, rudder bearings and rudder body are dealt with in the following. The steering gear shall comply with references given in Pt.4.

**1.1.4** The steering gear compartment shall be readily accessible and, as far as practicable, separated from machinery space.

**Note:**

Concerning use of non-magnetisable material in the wheel house in way of a magnetic compass, the requirements of the national administration concerned shall be observed.

---e-n-d---o-f---n-o-t-e---

#### 1.2 Rudder size (only for motor yachts)

**Guidance note:**

In order to achieve sufficient manoeuvring capability, the size of the movable rudder area  $A$  is recommended to be not less than obtained from following equation:

$$A = c_1 \cdot c_2 \cdot c_3 \cdot c_4 \cdot \frac{1.75 \cdot L \cdot T}{100} \text{ [m}^2\text{]}$$

where:

- $c_1$  = factor for yacht type
  - = 1.0 for motor yachts
- $c_2$  = factor for rudder type:
  - = 1.0 in general
  - = 0.9 for semi-spade rudders
  - = 0.7 for high lift rudders
- $c_3$  = factor for rudder profile:
  - = 1.0 for NACA-profiles and plate rudder
  - = 0.8 for hollow profiles and mixed profiles
- $c_4$  = factor for rudder arrangement:
  - = 1.0 for rudders in propeller jet
  - = 1.5 for rudders outside propeller jet.

For semi-spade rudders 50% of the projected area of the rudder horn may be included into the rudder area  $A$ . If several rudders are arranged, the area of each rudder may be reduced by 20%.

---e-n-d---o-f---g-u-i-d-a-n-c-e---n-o-t-e---

## 2 Rudder design loads

### 2.1 General

This paragraph is typically applicable for spade rudders, with its upper edge close to the hull.

It is assumed that the main dimensioning force is the resultant hydrodynamic lift force occurring at the design speed. Still, a rudder and its associated components and other affected structures have to cope with a minor drag force. For typical rudder shapes and arrangements the following methodology covers moderate astern speed.

For (forward) canard rudders, a separate load assessment shall be carried out, possibly including sea loads.

For twin rudders, the following applies for each rudder.

For any other type rudders, see [Sec.2](#).

### 2.2 Rudder loads

#### 2.2.1 Rudder hydrodynamic side force

The resultant hydrodynamic side force of a rudder for the purpose of assessing its scantlings shall be calculated using the following equation:

$$C_R = 0.136 \cdot c_L \cdot v_0^2 \cdot A \text{ [kN]}$$

where:

- $A$  = lateral area of rudder [m<sup>2</sup>]
- $v_0$  = design speed [kn] acc. [Ch.3 Sec.2 \[1\]](#)
- $c_L$  = maximum lift coefficient

$$c_L = \frac{0.11}{\left(1 + \frac{2}{AR_e}\right)} \cdot \alpha_0$$

- $\alpha_0$  = maximum angle of attack before stall [°]  
= 13° may be used in absence of value
- $AR_e$  = effective aspect ratio

$$AR_e = 2 \cdot \frac{b^2}{A}$$

- $b$  = see [Figure 1](#).

#### 2.2.2 Torsional moment

The maximum torque on rudder blade and rudder shaft shall be calculated using the following equation:

$$Q_R = C_R \cdot r \text{ [kNm]}$$

where:

- $r$  = distance between CoE and rudder shaft axis [m]  
=  $x_c - f$  if the axis of the rudder lies within the rudder  
=  $x_c + f$  if the axis of the rudder lies forward of the rudder.

$x_c$ ,  $f$  and  $r_{min}$  as in Figure 1.

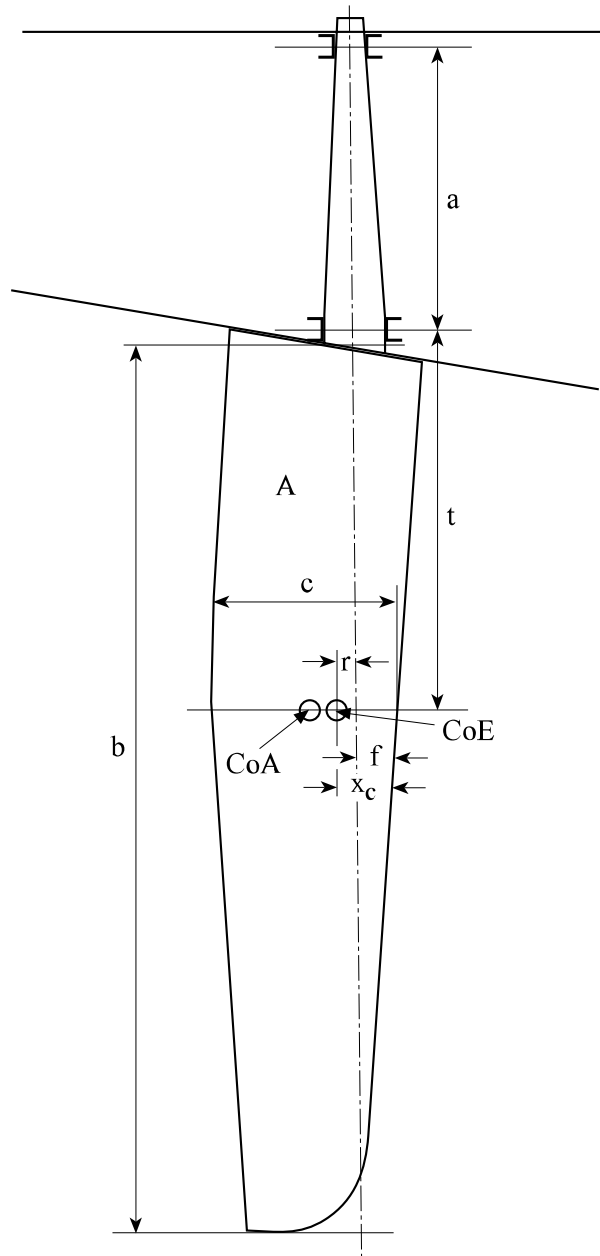

**Figure 1 Rudder**

- A** = geometric lateral area of the rudder blade
- CoA** = geometric centre of rudder blade
- CoE** = hydrodynamic centre of effort
- b** = mean span of the rudder blade

- $c$  = averaged profile depth of CoA , CoE  
 $c = \frac{A}{b}$
- $r$  = distance between CoE and rudder shaft axis  
 $= x_c - f$
- $r_{min}$  =  $0.1 \cdot c$
- $x_c$  =  $0.3 \cdot c$
- $f$  = lead of trailing edge forward of rudder axis
- $t$  = distance between CoE and centre of lower bearing
- $a$  = distance between bearing centres.

### 3 Rudder bearings

The rudder force  $C_R$  shall be shared between the individual bearings according to the vertical position of the rudder's geometric centre of effort which can be assumed to be located at the same height as the geometrical centre of the blade.

The reaction loads on the bearings shall be calculated as follows:

$$\text{Upper bearing: } B_2 = \frac{C_R \cdot t}{a}$$

$$\text{Lower bearing: } B_1 = B_2 + C_R$$

The same forces shall be used to design foundations or hull and deck reinforcements.

Rudder bearings shall provide sufficient rotational freedom to allow for a bent rudder shaft to avoid pertinent constraints on the bearing, the shaft and the affected hull structure.

### 4 Rudder scantlings

Rudder force and rudder torque as per [2.2.1] and [2.2.2] shall be used to design rudder stock and rudder blade scantlings. The rudder force shall be used as a lateral pressure force together with the relevant CoA/CoE to design the rudder and the stock at characteristic locations. The rudder torque at different locations shall be the rudder and the stock at characteristic locations. The rudder torque at different locations shall be derived using the local resultant pressure force, CoE and a torque lever as per definition from [2.2.2].

For fibre composite design, allowable strains in shaft and blade may not exceed limits as per definition in Ch.5.

Metal parts of the rudder shall be treated in accordance with allowable stresses defined in Sec.2 [1.4].

### 5 Rudder equipment

The rudder quadrant mounted on the shaft has to transmit torque without weakening the rudder shaft.

An emergency tiller is recommended being designed to cope with a rudder shaft torque resulting from 70% of the design speed  $v_0$ .

## SECTION 4 FIN STABILIZERS

### 1 General

The hydrodynamic effects of fin stabilizers on the rolling behaviour of the ship are not part of the classification procedure. The classification however includes the integration of the system into the hull structure.

For the mechanical, electrical and hydraulic part of the drive system see the Society rules for machinery steering and stabilization.

### 2 Integration into the ship's structure

#### 2.1

The complete bearing system and the drive unit directly mounted at the fin stock shall be situated within an own watertight compartment of moderate size at the ship's side or bottom. If this watertight compartment is flooded the bulkhead deck shall not be submerged. For installation purposes, inspection and maintenance watertight closable openings (with safeguards that they can be opened only during docking) shall be provided in suitable number and size.

#### 2.2

For retractable fins a recess of sufficient size to harbour the complete fin shall be provided in addition at the ship's shell.

#### 2.3

At the penetration of the fin stock and at the slot of retractable fins, the shell shall be strengthened in a sufficient way.

#### 2.4

The watertight boundaries of the fin recess, if applicable, and of the drive compartment shall be dimensioned according to [Ch.4 Sec.4 \[1\]](#). Special attention shall be given to the transmission of the fin support forces from the stock bearings into the ship's structure. The local reinforcements and the overall transmission of the forces by girders, web frames, etc. shall be defined by direct calculations considering fatigue strength and shall be included in the hull drawings submitted.

#### 2.5

If the fin body extends over the maximum breadth of the ship, the location of non-retractable fins should be marked on the shell.

## SECTION 5 WATERJETS

### 1 Design principles

#### 1.1

The reaction forces from the waterjet nozzles need to be transmitted into the hull structure in a manner for which adequate strength and fatigue life of critical details can be ensured through careful design.

For steerable jet units the reaction forces will typically arise from acceleration and manoeuvring actions (steering, reversing, crash-stop). For booster nozzles with no steering, reaction forces arise from acceleration only.

Additionally, vibration forces from impeller pulses/cavitation, turbulent waterflow in duct and around stator vanes, and various other possible sources (shaft misalignment, shaft/impeller imbalance, etc.) will be present.

#### 1.2

The nozzle reaction forces are normally transmitted into the hull structure through the duct and into the aft ship structure.

The jet duct and the details of this, such as flanges, bolted connections, discontinuities, butt welds and attachments, require special attention with respect to fatigue. The transom structure need to be designed so as to follow the deflections of the duct without excessive stress concentrations occurring in critical welds. The deflections of the duct and aft ship shall be kept within the tolerances of the impeller shafting and bearings.

#### 1.3

Design and workmanship of duct penetrations (shaft, inspection hatches, etc.), attachments and surrounding structure (stiffeners and frames) should be carried out with fatigue properties in mind.

Some general principles are listed below:

- increase thickness of main members and minimise panel stiffening (thickness of duct is normally not to be less than 1.5 times the bottom plating thickness)
- continuous welding
- shear connections between stiffeners and frames
- soft toe brackets
- avoid sniping of girder- and stiffener flanges in critical areas
- avoid termination of stiffeners and girders on plate fields
- avoid scallops where general stress levels are low
- avoid starts and stops of welding in corners and ends of stiffeners/brackets
- to improve fatigue properties of welded connections, welds and weld toes may be ground.

### 2 Duct design

#### 2.1

The duct(s) at transom shall be positioned in such a way as to give sufficient distance between the duct transom flange and ship side and bottom, and in the case of adjacent jets, between transom flanges, in order to allow flexing of transom plating, when ducts deflect due to the forces imposed by manoeuvring actions. Critical welded connections in the transom plate (duct transom flange/plating) shall be designed with respect to fatigue.

## 2.2

Geometry and details of tunnel to be specified based on results from tank tests if experience from comparable installation is not available. Documentation of such tank tests shall be submitted for information upon request.

## 3 Design loads

### 3.1

The following loading conditions shall normally be considered:

- crash stop
- maximum reversing load, from 10 knots
- maximum steering load
- waterjet unit weight accelerated as cantilever in pitching
- high cycle loads from impeller pulses, if available from the manufacturer.

Design forces/moments and information regarding weights shall be specified by the manufacturer of the waterjet.

## 4 Allowable stresses

### 4.1

For the crash stop load case, LCB according to [Ch.4 Sec.4 Table 1](#) shall be applied. The permissible stress for substructures is defined in: [Ch.4 Sec.3 \[6.2.3\]](#)

- For FRP constructions see [Ch.5](#).

### 4.2

For the steering, reversing and cantilever bending, the maximum allowable stresses shall be based on fatigue life considerations.

The number of cycles for each load case shall be based on the expected operational time during 25 years lifetime of the craft and should normally not be taken less than:

- $10^5$  cycles for reversing loads
- $5 \cdot 10^7$  cycles for steering loads
- $5 \cdot 10^7$  cycles for pitching loads

for craft operating under the widest service restrictions. Alternative cycles shall be specified.

For fatigue assessment of the duct, a fine mesh finite element analysis of the duct may be required undertaken and submitted for information upon request.

The fatigue assessment may be based on the Miner-Palmgren rule for accumulated fatigue damage, and the *ECCS European recommendations for aluminium alloy structures fatigue design*.

## 5 Bolt connections

### 5.1

The number of bolts for standard flange connections shall normally not be less than:

$$N_b = \frac{\pi \cdot D_b}{2 \cdot t_f + d_w}$$

where:

$D_b$  = diameter to bolt centre

$d_w$  = diameter nut/washer

$t_f$  = thickness of the aluminium flange.

For duct flanges of other material than aluminium, the bolt connection shall be considered in each case.

### 5.2

Insulating gaskets and washers (if fitted) shall be thin and have high modulus of elasticity.

### 5.3

Documentation regarding pretension, calculated bolt maximum forces/stresses, as well as dynamic forces/stresses, shall be submitted for information upon request.

## SECTION 6 FOUNDATIONS

### 1 General

#### 1.1 Scope

This section covers only the standard forms of foundations having a widespread application in yards. Exceptional types and forms will be especially considered.

#### 1.2 Definitions

For the definitions of positions 1 and 2 as well as of the standard height of superstructures see [Ch.1 Sec.2](#).

|       |  |
|-------|--|
| $P$   | = rated output of engine, gear or generator, in kW                   |
| $t_p$ | = thickness of top plate, see <a href="#">[3.2.3]</a>                |
| $d$   | = diameter of the foundation bolts, in mm                            |
| $t_c$ | = corrosion addition according to <a href="#">Ch.4 Sec.3 [5.1]</a> . |

### 2 Foundations

#### 2.1 General

Foundations for all types of equipment on board of yachts are fulfilling the following tasks:

- transmission of static/dynamic forces and moments created by the equipment itself as well as created by ship motions to the hull structure
- reduction of transmission of dynamic peak loads and vibrations to the ship's structure
- reduction of structure-borne noise transmitted from the machinery mounted on the foundation.

#### 2.2 Methods of analysis and design principles

##### 2.2.1 Methods of analysis

Foundations shall be analysed together with their structural integration. In general a static structural analysis of the foundations may be sufficient. In special cases, however, a dynamic analysis may be required. Regarding groups of similar foundations and substructures it is sufficient to examine one representative unit. It has to be verified that the foundation has the stiffness required in the equipment specification and that the deflections are within the permissible range.

##### 2.2.2 Design details

Foundations fitted on decks and walls in highly stressed areas of the hull girder shall be designed with respect to sufficient fatigue strength.

### 3 Foundations for main propulsion engines

#### 3.1 General

**3.1.1** The following requirements apply to foundations of diesel engines, gears, gas turbines and generators.

**3.1.2** The rigidity of the engine seating and the surrounding bottom structure shall be adequate to keep the deformations of the system within the permissible limits. In special cases, proof of deformations and stresses may be required.

**3.1.3** Due regard shall be paid to a smooth flow of forces in transverse and longitudinal direction.

**3.1.4** The foundation bolts for fastening the engine at the seating shall be spaced no more than 3 d apart from the longitudinal foundation girder. Where the distance of the foundation bolts from the longitudinal foundation girder is greater, proof of equivalence shall be provided.

**3.1.5** In the whole speed range of main propulsion installations for continuous service resonance vibrations with inadmissible vibration amplitudes shall not occur; if necessary structural modifications shall be provided for avoiding resonance frequencies. Otherwise, a barred speed range has to be fixed. Within a range of -10% to +5% related to the rated speed no barred speed range is permitted. The Society may require a vibration analysis and, if deemed necessary, vibration measurement.

## 3.2 Longitudinal girders

**3.2.1** The thickness of the longitudinal girders above the inner bottom or deck for gears or generators shall not be less than:

$$t = \sqrt{\frac{P}{200}} + 2 \text{ [mm]}, \text{ but not less than } 0.4 t_p.$$

**3.2.2** For the thickness of the longitudinal girders for gas turbines above the inner bottom, the manufacturer's requirements shall be additionally considered.

**3.2.3** The sizes of the top plate (width and thickness) shall be sufficient to attain efficient attachment and seating of the engine and – depending on seating height and type of engine – adequate transverse rigidity.

The thickness of the top plate in mm shall be not less than:

$$t_p = 0.9 \cdot d$$

The cross sectional area of the top plate shall not be less than:

$$A_T = \frac{P}{15} + 30 \text{ [cm}^2\text{]}, \text{ for } P \leq 750 \text{ kW}$$

$$A_T = \frac{P}{75} + 70 \text{ [cm}^2\text{]}, \text{ for } P > 750 \text{ kW}$$

**3.2.4** For elastically mounted high speed engines ( $n > 1000 \text{ min}^{-1}$ ) the cross sectional area of the top plate may be reduced to:

$$A_T = \frac{P}{40} + 14 \text{ [cm}^2\text{]}, \text{ for } P \leq 750 \text{ kW}$$

$$A_T = \frac{P}{200} + 29 \text{ [cm}^2\text{]}, \text{ for } P > 750 \text{ kW}$$

**3.2.5** Where twin engines are fitted, a continuous top plate shall be arranged in general if the engines are coupled to one propeller shaft.

**3.2.6** Top plates shall preferably be connected to longitudinal and transverse girders thicker than approximately 15 mm by means of a double bevelling butt joint (K butt joint), see also [Ch.4 App.C Table 3](#).

### 3.3 Transverse support of longitudinal girders

**3.3.1** The longitudinal girders of the engine seating shall be supported transversely by means of web frames or wing bulkheads. The scantlings of web frames shall be determined according to [Ch.4 Sec.3](#).

### 3.4 Azimuthing propulsors

The space where the azimuthing propulsor unit is connected to the ship hull in general shall be surrounded by longitudinal and transverse watertight bulkheads. Suitable watertight access openings to the space shall be provided.

#### 3.4.1 Loads

The following loads shall be considered for the determination of the scantlings of the supporting structure:

- maximum transient thrust, torque and other forces and moments experienced during all envisaged operating modes as permitted by the steering and propulsor drive control systems. See also [Pt.4](#)
- self weight in water under consideration of the ship's pitch and heave motion and flooded volume, where applicable, see [Ch.3 Sec.3 \[1\]](#)
- propulsor to propulsor and/or propulsor to ship hydrodynamic interference effects and effects of ship manoeuvring and of ship motions.

Special account shall be taken of any manoeuvring conditions that are likely to give rise to high mean or vibratory loadings.

#### 3.4.2 Support structure

A system of primary structural members shall be provided in order to support the main slewing bearing of the propulsor unit and to transfer the maximum design loads into the ship's hull without undue deflection.

The hull support structure in way of the slewing bearing shall be sufficiently stiff that the bearing manufacturer's limits on seating flatness are not exceeded due to hull flexure considering the loads defined under [\[3.4.1\]](#). For the verification of the structural design direct calculation is required, see [\[3.4.3\]](#).

Propulsors should be supported where practical within a double bottom structure. Generally a system of primary members including a pedestral girder directly supporting the slewing ring and bearing shall be provided. The pedestral girder shall be integrated with the ship's structure by means of radial girders and transverses aligned to their outer ends with the ship's bottom girders and transverses. Alternative arrangements shall provide an equivalent degree of strength and rigidity.

The shell envelope plating and tank top plating in way of the aperture for the propulsor shall be increased by 50% over the rule minimum thickness over an extent of at least the radial girders. In any case the thickness of the plating shall not be less than the actual fitted thickness of the surrounding shell or tank top plating.

The scantlings of the primary members of the support structure shall be based on the design stresses defined in [\[3.4.3\]](#). Primary member scantlings shall not be less than those required by [Ch.4 Sec.3](#).

The web thickness of the pedestral girder shall not be less than the required shell envelope minimum rule thickness at that position.

Full penetration welds shall be applied at the pedestral girder boundaries and in way of the end connections between the radial girders and the pedestral girder.

#### 3.4.3 Direct calculations

As a guideline for geometry modelling, selection of element types etc. [Ch.6](#) shall be considered. The mesh geometry and the element size shall be able to reflect the stiffness of the supporting structure as well as the deformations with sufficient accuracy. For vibration analysis the model shall be able to reflect the expected frequency range. For fatigue assessment [Ch.4 App.D](#) shall be considered.

The applied load, refer to [\[3.4.1\]](#), shall include the self-weight, dynamic acceleration due to ship motion, hydrodynamic loads, hydrostatic pressure, propeller forces and shaft bearing support forces. In situations

where a propulsor can operate in the flooded conditions or where flooding of a propulsor unit adds significant mass to that unit, details shall be included.

Based on the most unfavourable combination of normal service conditions, the following stresses shall not be exceeded:

|                                  |                            |
|----------------------------------|----------------------------|
| Shear stress:                    | $0.38 \cdot f_m \cdot R_y$ |
| Bending stress:                  | $0.64 \cdot f_m \cdot R_y$ |
| Equivalent von Mises stress:     | $0.77 \cdot f_m \cdot R_y$ |
| Localised von Mises peak stress: | $1.0 \cdot f_m \cdot R_y$  |

With  $f_m$  the material factor according to [Ch.4 Sec.4](#).

If the design is based on extreme or statistically low probability loads, proposals to use alternative acceptance stress criteria may be considered.

Where a fatigue assessment is provided, details of cumulative load history and stress range together with the proposed acceptance criteria shall be submitted for consideration. See also [Ch.4 App.D](#).

For cast structures, the localised von Mises stress should not exceed 0.6 times the nominal 0.2% proof or yield stress of the material for the most unfavourable design condition.

## 4 Foundations for auxiliary engines

For mechanical and electrical installations the loads on the foundations are created by their weight, and all reaction forces and moments resulting from the most unfavourable operating conditions shall be considered in addition. The cross sectional area of the top plate may be determined according to [\[3.2.4\]](#).

## 5 Foundations for deck machinery and mooring equipment

### 5.1

For windlasses and chain stoppers the acting forces on the foundation shall be calculated for 100% of the nominal breaking load of the chain cable.

Where windlass and chainstopper are not integral, the windlass including its brake shall be designed to withstand 60% of the breaking load of the chain cable.

For the supporting structure under this equipment 100% of the minimum yield stress  $R_y$  shall be observed as acceptance criterion in the calculation.

For composite foundations the maximum stress may not exceed 60% of the ultimate strength.

### 5.2

See also [DNVGL-RU-SHIP Pt.3 Ch.11 Sec.1](#) and [DNVGL-RU-SHIP Pt.3 Ch.11 Sec.2](#).

## SECTION 7 PROPELLER SHAFT BRACKETS

### 1 General

The strut axes should intersect in the axis of the propeller shaft as far as practicable. The angle between the two struts shall be in the range of 60° to 120°. An angle of approximately 90° is recommended where 3- or 5-bladed propellers are fitted or approximately 70° or 110° in case of 4-bladed propeller, respectively.

The struts shall be extended through the shell plating and shall be attached in an efficient manner to the frames and plate floors respectively. The construction in way of the shell shall be carried out with special care.

A watertight compartment of moderate size shall be provided within the strut structure inside the shell to reduce the effect of flooding in case of damage.

In case of welded connection, the struts shall have a weld flange or a thickened part shall be connected with the shell plating in another suitable manner. The requirements of Ch.4 App.C [2.4.3] shall be observed.

Welds between propeller brackets and bottom plate shall be tested by NDT adequately.

The struts shall be well rounded at fore and aft end at the transition to the hull as well as at the boss.

If propulsion system elements will be fastened to the hull by means of a cast-resin, fitting shall be carried out according to the specification by the cast-resin manufacturer and in the presence of a representative of manufacturer or an authorized person as well as a Society's surveyor.

### 2 Metallic shaft brackets

#### 2.1 Symbols and definitions

If applicable, the corresponding drawing shall consist following information for each type of propeller bracket, see also Figure 1:

$$d_0 = f_1 \cdot f_2 \cdot f_3 \cdot 3 \sqrt[3]{\frac{P_w \cdot C_w}{n \cdot \left(1 - \left(\frac{d_i}{d_a}\right)^4\right)}}$$

where:

|       |  |
|-------|--|
| $P_w$ | = rated power in kW  |
| $n$   | = shaft speed at rated power, in $\text{min}^{-1}$   |
| $n_0$ | = $n$ , but shall not be taken less than $350 \text{ min}^{-1}$  |
| $R_m$ | = specified minimum tensile strength of shaft material, in MPa   |
| $C_w$ | $C_w = \frac{560}{160 + R_m}$  |
| $f_1$ | = 95 in general<br>= 90 for sailing yacht  |
| $f_2$ | = 1.1 for unlimited service range and restricted service area <b>R0</b><br>= 1.0 for restricted service area <b>R1</b><br>= 0.95 for restricted service area <b>R3</b> and <b>RE</b> |
| $f_3$ | = 1.0 single propulsion shaft<br>= 0.9 double (or more) propulsion shafts  |
| $d_a$ | = actual outer propeller shaft diameter, in mm   |

$d_i$  = actual inner shaft diameter, in mm

$$d = \sqrt[3]{\frac{d_a^4 - d_1^4}{d_a}}$$

$L_0$  = distance between propeller CoG and centre of aft bearing, in m

$L_1$  = distance between bearing of propeller bracket and next radial bearing, in m

$L$  =  $L_0 + L_1$

$l$  = distance between centreline of shaft boss and hull support, in m

$\Delta l$  = distance between centreline of shaft boss and the intersection of the strut axes of double arm brackets, in m

$\beta$  = angle between centreline of shaft and strut axis, in degree.

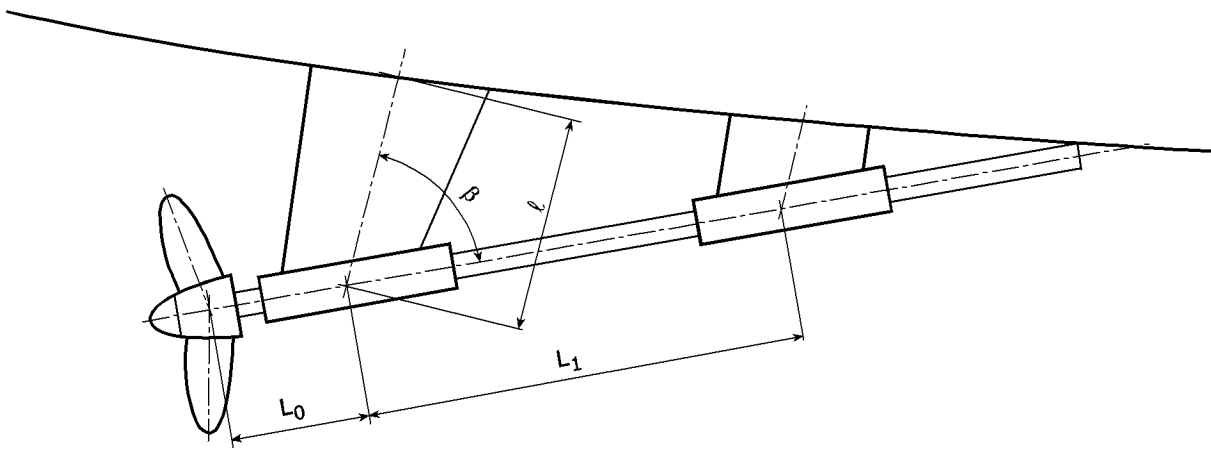

**Figure 1 Dimensions of propeller shaft brackets**

## 2.2 Double arm propeller brackets

The scantlings of solid or welded double arm shaft struts each shall be determined by following equations:

$t$  = strut thickness [mm]

$$t = \frac{c_1 \cdot d}{\sin(\beta)}$$

$A$  = area of strut section [cm<sup>2</sup>]

$$A = \frac{c_2 \cdot d_0^2}{100} \cdot \sqrt{2 + \cos(2\beta)} \cdot \left(1.0 + \frac{\Delta l}{2 \cdot l}\right)$$

$c_1$  = 0.32 for steel

= 0.54 for aluminium alloys

$c_2$  = 0.30 for steel

= 0.86 for aluminium alloys.

The thickness of the plating of constructed propeller brackets shall not be less than:

$$t_{\min} = 0.1 d_0 \text{ [mm]}.$$

## 2.3 Single arm bracket

The section modulus shall not be less than:

$W$  = section modulus of strut [cm<sup>3</sup>]

$$W = \frac{c_3 \cdot l}{1000} \cdot d_0^{2.5} \cdot \sqrt{n_0} \cdot \frac{L}{L_1}$$

$c_3$  = 0.102 for welded steel connection  
= 0.291 for welded aluminium connection.

Built-up (welded construction) shaft struts should not be used for single arm struts.

For cast resin foundation the value of factor  $c_3$  may be reduced to

$c_3'$  = 0.076 for steel struts which are not welded in way of foundation  
= 0.262 for aluminium struts which are not welded in way of foundation.

An increased strut length  $l$  (in comparison with welded strut joints) shall generally be taken into account for cast resin foundations.

A crack detection of the propeller brackets shall be employed every time when the ship is in dry-dock or on a slipway.

## 2.4 Intermediate struts

**2.4.1** The scantlings of intermediate struts may be determined by following equations:

$$t = \frac{c_1 \cdot d}{\sin(\beta)} \cdot \sqrt{\frac{L_0}{L_1}} \text{ [mm]}$$

$$A = \frac{c_2 \cdot d_0^2}{110} \cdot \sqrt{2 + \cos(2\beta)} \cdot \left(1.0 + \frac{\Delta l}{2 \cdot l}\right) \cdot \frac{L_0}{L_1} \text{ [cm}^2\text{]}$$

**2.4.2** And in addition for single struts:

$$W = \frac{c_3}{1150} \cdot l \cdot d_0^{2.5} \cdot \sqrt{n_0} \cdot \frac{L \cdot L_0}{L_1^2} \text{ [cm}^3\text{]}$$

## 2.5 Boss

The length of the boss is determined by the necessary length of the bearing for the propeller shaft according to Pt.4.

The wall thickness of the boss shall not be less than 0.2  $d$ .

### 3 Composite shaft brackets

The following assumption is based on the fact that the shaft bracket is failing subsequent to the propeller shaft itself. Failure of the propeller shaft is in rotational bending due to the imbalance force  $F_u$  between its supports, the shaft bracket and the stern tube bearing or other radial support bearing.

Design load in any radial direction:

$$F_u = 0.011 \cdot \frac{E_s}{210000MPa} \cdot d_0^2 \cdot \sqrt{n \cdot d_0} \cdot \left(1 + \frac{L_0}{L_1}\right)$$

where:

- $F_u$  = design radial force [N] in way of propeller CoG
- $E_s$  = Youngs modulus of propeller shaft material
- $d_0$  = propeller shaft diameter [mm]
- $n$  = shaft revolutions at nominal speed [1/min];  $n > 350$  /min
- $L_0$  = distance between bracket centre and propeller CoG
- $L_1$  = distance between bracket centre and next radial bearing.

Permissible material stresses/strains and safety factors for composite components of propeller brackets and associated structures subject to the load  $F_u$  are defined in [Ch.5 Sec.6](#), where these permissible strains/stresses shall be 1.2 times lower than those defined and safety factors 1.2 times higher than those defined.

## SECTION 8 SAILING YACHT KEELS

### 1 General

The structure of the ballast keel and also the yacht's bottom and floor structure in way of the keel attachment shall be able to withstand the structural loadings described below. All relevant structural components of such an assembly shall be assessed, at multiple locations, if necessary (e.g. keel fin, bearings, etc.).

#### 1.1 Design loads

The following design loads are for fixed keels, lifting keels and canting keels. In general, the below load cases apply to lifting keels only in fully-up (fixed) or fully-down (fixed) positions. For lifting and lowering sequences structures need to be sound under moderate motions of the vessel, lifting and lowering shall only be performed in relatively calm water. Lifting and lowering in shallow water may only be performed at zero speed over ground. A canting keel will have to undergo assessment with the keel canted in different angles. The following cases may be assessed separately for the purpose of deriving scantling requirements.

##### 1.1.1 LC1 keel load heeling

$$F_1 = \pm 1.0 \cdot mk_1 \cdot g \cdot c_d$$

where:

- $c_d$  = dynamic offset factor
  - = 1.0 for fixed keel or lifting keels with the boat heeled to 90°
  - = 1.0 for lifting keels with keel in fully-up position, when not used for sailing, with boat heeled to 30°
  - = 1.4 for canting keels with keel at maximum canting angle and boat heeled to 30°
- $mk_1$  = mass of keel (in general: fin and bulb) relevant to structural assessment
- $g$  = acceleration of gravity
  - = 9.81 m/s<sup>2</sup>.

For the determination of structural response on keel design forces  $F_1$ , relevant values of  $mk$ , occurring at pertinent centre of gravity in the direction of gravity, shall be taken to assess structural aspects at different locations, e.g. keel root, keel box, half span of fin or bulb attachment.

##### 1.1.2 LC2 keel load pounding

$$F_{2(z)} = -1.1 \cdot g \cdot (\Delta_F - mk_1)$$

where:

- $\Delta_F$  = displacement of vessel fully loaded.

For the determination of structural response, the vertical design force is acting upwards on the bulb bottom, in line with total keel centre of gravity with the boat upright; canting keels with keel in 0° cant position.

##### 1.1.3 LC3 keel load grounding

$$F_{3(x)} = -1.5 \cdot g \cdot (\Delta_F - mk_2)$$

$$F_{3(y)} = \pm 0.2 \cdot c_c \cdot F_{3(x)}$$

where:

$mk_2$  = concentrated mass of keel in way of grounding contact (in general: bulb)

$c_c$  = according to Ch.3 Sec.2 [1.1], but without minimum restriction.

For the determination of structural response, the design forces shall be applied to the foremost tip of the keel bulb with boat in upright situation and canting keel in 0° and max. canting angle position. x and y coordinates are in boat-fixed coordinate system.

## 2 Keel and keel attachment scantling determination

### 2.1 Metal construction

#### 2.1.1 Permissible stresses

Nominal stresses for all metal components of a keel arrangement subject to the loads as specified in [1.1] shall not exceed values as specified Table 1 and Table 2. Stress concentrations shall be assessed case by case.

**Table 1 Permissible stresses for keel structural elements not subjected to local stress concentration**

|                  | LC1   | LC2   | LC3   |
|------------------|-------|-------|-------|
| $\sigma_{v-all}$ | 145/k | 145/k | 180/k |
| $\sigma_{all}$   | 120/k | 120/k | 150/k |
| $\tau_{all}$     | 80/k  | 80/k  | 90/k  |

**Table 2 Permissible stresses for keel structural elements subjected to local stress concentration (e.g. threads, etc.)**

|                  | LC1   | LC2   | LC3   |
|------------------|-------|-------|-------|
| $\sigma_{v-all}$ | 125/k | 125/k | 150/k |
| $\sigma_{all}$   | 110/k | 110/k | 140/k |
| $\tau_{all}$     | 70/k  | 70/k  | 80/k  |

LC1 to LC3 are defined in [1.1.1] to [1.1.3].

$\sigma$ -stresses are axial stresses generated from tension, compression and bending.  $\tau$ -stresses are generated from shear forces and torque.

von Mises stresses  $\sigma_v$  shall be calculated as follows:

$$\sigma_v = \sqrt{\sigma^2 + 3 \cdot \tau^2}$$

### 2.1.2 Material factor $k$

The material factor  $k$  for steels and aluminum alloys for the use in keel design shall be determined as follows:

$$\left(\frac{235}{R_{eH}}\right)^{0.75} \text{ for } R_y > 235 \text{ MPa}$$
$$k = \frac{235}{R_{eH}} \text{ for } R_y \leq 235 \text{ MPa}$$

where:

$R_y$  = yield strength of material.

### 2.1.3 Fatigue assessment

A separate fatigue assessment is required, in particular for welded constructions. Relate to [Ch.4 App.D](#).

### 2.1.4 Fibre reinforced composites

Permissible material strains and safety factors for components of keel and associated structures subject to the loads as specified in [\[1.1\]](#) are defined in [Ch.5](#), where these permissible strains may be 1.4 times higher and safety factors 1.4 times lower for loadcase 3.

## SECTION 9 CHAINPLATES FOR SAILING YACHT

### 1 General

The following specifies scantling requirements for the chainplates and their structural attachment to the yacht's hull.

Sailing yachts shall have transverse bulkheads or equivalent structures in way of mast(s) in order to achieve adequate transverse rigidity. Bulkheads or deep brackets shall be provided in way of chain plates. Any other arrangement shall be subject to special approval.

### 2 Chainplates and substructures

#### 2.1 Design loads

Where no other indications are available, the dimensioning load will be equal to the breaking load of the attached shrouds and stays.

If there are two shrouds attached to a chainplate, the dimensioning load for the chainplate is  $F = 1.0$  times the breaking load of the stronger shroud plus 0.5 times the breaking load of the weaker shroud [kN].

#### 2.2 Permissible stresses

For dimensioning of chainplates made of metallic materials the following permissible stresses shall be complied with:

$$\tau = \frac{R_y}{\sqrt{3}} \text{ [MPa]}$$

— permissible bearing stress between chainplate and pin

$$\sigma_{LL, perm} = \frac{R_y + R_m}{2} \text{ [MPa]}$$

— for tension and shear loading:

$$\sigma_{perm} = R_y \text{ [MPa]}$$

$$\tau = \frac{R_y}{\sqrt{3}} \text{ [MPa]}$$

where:

$R_y$  is the steel's minimum nominal upper yield point  $R_{eH}$  or  $R_{p0.2}$  in case of aluminium alloys, respectively in MPa.

#### 2.3 Determination of chainplate geometry

##### 2.3.1 Metallic chainplates

Determination of geometry and thickness of a metallic chainplate according to [Figure 1](#)

$$a_{\min} = \frac{F}{2 \cdot t \cdot \sigma_{perm}} + \frac{2}{3} \cdot d_L \text{ [mm]}$$

$$c_{\min} = \frac{F}{2 \cdot t \cdot \sigma_{perm}} + \frac{1}{3} \cdot d_L \text{ [mm]}$$

where:

$d_L$  = pin hole diameter [mm]  
 $t$  = thickness of the chainplate [mm].

It is assumed that the gap between bearing hole and pin is smaller than  $0.1 d_L$ . Also the bearing stress limit according to [2.2] shall be observed.

### 2.3.2 Metallic chainplate structure

The dimensioning principles, i.e. design load and permissible stress for chainplates of metallic materials as outlined above shall be applied analogously to the metallic chainplate substructure, e.g. tie rods, etc.

### 2.3.3 Chainplates of composite materials

Regarding chainplate components made of composite materials, e.g. carbon fibre tapes, and composite structures to which chainplates are attached, e.g. FRP bulkheads, dimensioning shall be carried out as follows.

## 2.4

The relevant stress in the composite component, e.g. tension or shear, shall be calculated applying the design load according to [2.1].

## 2.5

The permissible stress shall be less than or equal to the ultimate stress of the composite component divided by 1.6.

### 2.5.1 Structural members in way of chainplates

Scantlings of structural members in way of chainplates shall ensure sufficient strength and rigidity of the hull under the consideration of the design loads defined in [2.1].

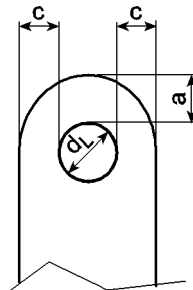

**Figure 1 Geometry of the chainplate**

## CHANGES – HISTORIC

### July 2018 edition

#### Changes July 2018, entering into force 1 January 2019

| <i>Topic</i>  | <i>Reference</i>      | <i>Description</i>  |
|---|-----------------------|---|
| Restructured Sec.1 for improved readability and clarity | <a href="#">Sec.1</a> | The section has been restructured for improved readability and clarity. |

### July 2017 edition

#### Amendments January 2018

| <i>Topic</i>                | <i>Reference</i> | <i>Description</i>                        |
|-----------------------------|------------------|---|
| Fibre reinforced composites | Sec.8 [2.1.4]    | Complete definition and correct reference |

#### Changes July 2017, entering into force 1 January 2018

| <i>Topic</i>        | <i>Reference</i>                | <i>Description</i>                                  |
|---------------------|---------------------------------|---|
| Sailing yacht keels | Sec.8 Table 1 and Sec.8 Table 2 | Correction of table based on engineering principles |

### October 2016 edition

#### Main changes October 2016, entering into force as from date of publication

- Sec.2 Metal rudders
  - Sec.2 [1.4.2]: Non-used definitions were deleted
  - Sec.2 [2.1.1]: Formula corrected
  - Sec.2 [3.1.1]: Formulas corrected
  - Sec.2 [3.2.1]: Formula corrected and units changed
  - Sec.2 [3.3.2]: Formula changed
  - Sec.2 [3.4]: Introduction of factor
  - Sec.2 [4.1]: Formula corrected
  - Sec.2 [4.3]: Formula corrected
  - Sec.2 [4.4]: Formula corrected
  - Sec.2 [5.2]: Formula corrected
  - Sec.2 [5.3]: Formula corrected
  - Sec.2 [5.4]: Formula corrected

- Sec.2 [5.5]: Formula corrected
- Sec.2 [6.2.1]: Formula corrected
- Sec.2 [6.2.2]: Formula corrected
- Sec.2 [6.3.1]: Formula corrected and units changed
- Sec.2 [6.3.2]: Formula corrected and units changed
- Sec.2 [7.2.1]: Formula corrected
- Sec.2 [7.2.3]: Formula corrected
- Sec.2 [7.4.4]: Formula corrected an units changed
- Sec.2 [7.5.1]: Formula corrected and change of unit
- Sec.2 [7.5.2]: Formula corrected
- Sec.2 [8]: Formula corrected.

- Sec.3 Composite rudders

- Minor corrections done.

- App.A Keel fatigue assessment

- Removed and reference change to Ch.4 App.D.

## **December 2015 edition**

---

This is a new document.

The rules enter into force 1 July 2016.

### **About DNV GL**

DNV GL is a global quality assurance and risk management company. Driven by our purpose of safeguarding life, property and the environment, we enable our customers to advance the safety and sustainability of their business. We provide classification, technical assurance, software and independent expert advisory services to the maritime, oil & gas, power and renewables industries. We also provide certification, supply chain and data management services to customers across a wide range of industries. Operating in more than 100 countries, our experts are dedicated to helping customers make the world safer, smarter and greener.

SAFER, SMARTER, GREENER