

**B3L** (gasoline)  
**D3L** (diesel fuel)

Air heaters independent of engine  
 for universal installation

VEHICLES HEATERS

J. EBERSPÄCHER  
 EBERSPÄCHERSTRASSE 24  
 D-7300 ESSLINGEN  
 TEL: (0714) 3109-0  
 TELEFAX: 7266426  
 TELEFAX: (0714) 3109-626

**B 3 L – consisting of:**  
 Basic heater with standard equipment  
 Universal installation kit  
 Control elements (to be ordered separately, see p. 2)  
 See Additional Equipment Catalog for other accessories

**Cat. No.**  
 20 1643 05 00 00 (12 V)

25 1482 80 00 00

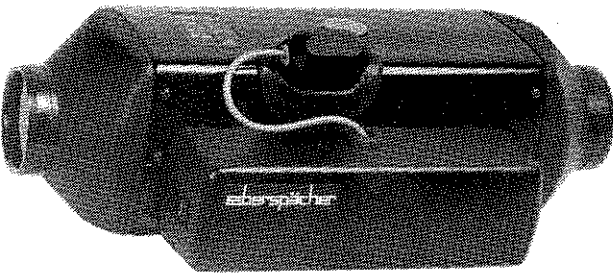

**D 3 L – consisting of:**  
 Basic heater with standard equipment  
 or  
 Basic heater with standard equipment  
 or  
 Basic heater with standard equipment and universal installation kit in each instance  
 Control elements (to be ordered separately, see p. 2)  
 See Additional Equipment Catalog for other accessories

**Cat. No.**  
 25 1482 05 00 00 (12 V)<sup>1)</sup>  
 25 1483 05 00 00 (24 V)<sup>1)</sup>

25 1640 05 00 00 (12 V)<sup>2)</sup>  
 25 1641 05 00 00 (24 V)<sup>2)</sup>

25 1573 05 00 00 (24 V)<sup>3)</sup>  
 25 1642 05 00 00 (24 V)<sup>7)</sup>  
 25 1482 80 00 00

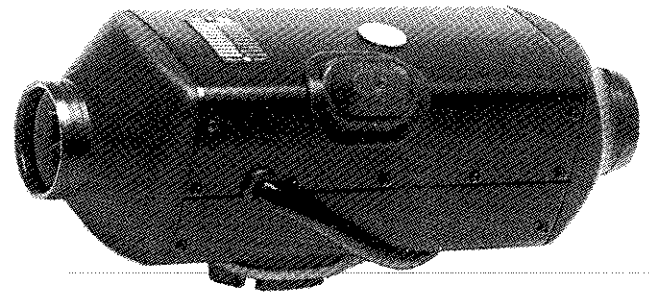

**Specifications**

Heating medium: Air  
 Heating-air flow<sup>4)</sup> (without counterpressure): 160 kg/h ± 10%  
 Heating capacity<sup>4)</sup>:  
 B 3 L: 3000 Watts ± 10%  
 D 3 L: Full: 3200 Watts ± 10%  
 Half: 1600 Watts ± 10%<sup>6)</sup>  
 Regulation of heating capacity:  
 B 3 L: On-Off, possible with room thermostat  
 D 3 L: Full-Half at On-Off switch or with room thermostat  
 Fuel:  
 B 3 L: Gasoline (commercial grade).  
 D 3 L: Diesel fuel (commercial grade). See also "Fuel at Low Temperatures".  
 Fuel consumption<sup>4)</sup>:  
 B 3 L: 0,39 l/h ± 5%  
 D 3 L: 0,38 l/h ± 5%  
 Rated voltage: 12 V or 24 V  
 Operating range:  
 Minimum voltage:<sup>5)</sup> 10 V or 20 V respectively  
 Maximum voltage:<sup>6)</sup> 14 V or 28 V respectively

Electric power consumption:<sup>4)</sup>  
 B 3 L: at start: 170 Watts ± 10%  
 in operation: 50 Watts ± 10%  
 D 3 L: at start: 280 Watts ± 10%  
 with 12 V: 520 Watts ± 10%  
 with 24 V: 45 Watts ± 10%  
 in operation:  
 Ventilation: Possible with suitable circuit arrangement  
 Degree of radio interference suppression: Remote, additional interference suppression measures possible  
 Weight: approx. 6.5 kg  
<sup>1)</sup> design with full-half setting of heating capacity and undervoltage safety device  
<sup>2)</sup> with glow plug current regulator, otherwise as <sup>1)</sup>  
<sup>3)</sup> design with cable harness, 2 m long, between heater and control unit, otherwise as<sup>1)</sup>  
<sup>4)</sup> at rated voltage  
<sup>5)</sup> An undervoltage safety device built into the control unit switches off the heaters when at around 10.5 and 21 V respectively.  
<sup>6)</sup> in the case of B 3 L an overvoltage safety device built into the control unit switches off the heaters when at approx. 15 V.  
<sup>7)</sup> design with cable harness, 2 m long, between heater and control unit, otherwise as <sup>2)</sup>

## Contents

	Page
Scope of delivery/Cat. No. . . . .	2
Installation instructions . . . . .	4
Approval, official regulations, general . . . . .	4
Typical installations/installation location . . . . .	4
Installing the heater . . . . .	5
Principal dimensions . . . . .	5
Permissible installation positions . . . . .	6
Running the heating air . . . . .	7
Running the combustion air . . . . .	8
Running the exhaust . . . . .	8
Fuel supply . . . . .	9
Electrics/wiring diagrams . . . . .	11
Description of operation . . . . .	15
Elimination of faults, fuel at low temperatures . . . . .	16
Operating instructions are supplied with control elements	

## Scope of delivery (See page 3 for illustration)

Item	Qty.	Designation
<b>B 3 L</b>	1	Basic heater with standard equipment: Cat. No. 20 1643 05 00 00 (12 V) including items 1, 4 and 5
1	1	Basic heater 20 1643 01 - (12 V) not available alone
4	1	Fuel metering pump
5	1	Intake silencer

for additional orders, see under D 3 L

<b>D 3 L</b>	1	Basic heater with standard equipment: Cat. No. 25 1482 05 00 00 (12 V) optionally { 25 1483 05 00 00 (24 V) 25 1573 05 00 00 (24 V) including items 1-5
1	1	Basic heater { 25 1482 01 (12 V) not available alone { 25 1483 01 (24 V) 25 1573 01 (24 V)
2	1	Control unit
3	1	Holder
4	1	Fuel metering pump
5	1	Intake silencer

or

1	1	Basic heater with standard equipment Cat. No. 25 1484 05 00 00 (12 V) 25 1485 05 00 00 (24 V) 20 1642 05 00 00 (24 V) including items 1-5
1	1	Basic heater { 25 1640 01 (12 V) 25 1641 01 (24 V) 25 1642 01 (24 V)

2	1	Control unit
3	1	Holder
4	1	Fuel metering pump
5	1	Intake silencer
-	1	<b>and, additionally to be ordered for B 3 L and D 3 L:</b> Universal installation kit Cat. No. 25 1482 80 00 00 including items 21 to 75
76	1	Reinforcing plate, if necessary Cat. No. 20 1577 89 00 03

## Control elements

<b>6</b>	<b>1</b>	<b>Heating timer, compl. (optional)</b> Cat. No. 25 1482 89 09 00 (12 V) 25 1482 89 10 00 (24 V) including items 6a-f
6a-f	1	Heating timer and fasteners
<b>7</b>	<b>1</b>	<b>Heating timer, compl. (optional)</b> Cat. No. 25 1482 89 19 00 (12 V) 25 1483 89 02 00 (24 V) including items 7a-7h
7a-h	1	Heating timer and fasteners

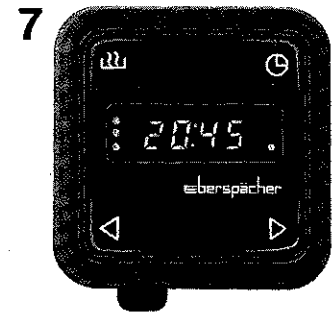

## 7.1



<b>Timer</b>	<b>Cat. No.</b>
12 V	25 1482 89 35 00
24 V	25 1483 89 07 00
Fasteners (only required for installation with screen)	
Cat. No.	25 1482 70 01 00

<b>8</b>	<b>1</b>	<b>Universal switch, compl. (optional)</b> including items 8a-8d Cat. No. 25 1380 89 04 00
8a	1	Universal switch
8b	3	Operating instructions plates
8c	3	Operating instructions
8d	1	Installations instructions for switch
9	1	Bulb Cat. No. 207 00 005 (12 V) 207 00 006 (24 V)



D 3 L version  
25 1482/25 1483

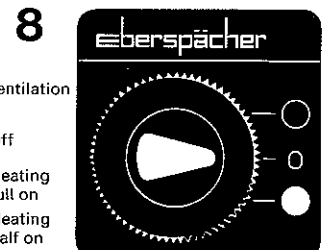

B 3 L  
D 3 L version  
25 1484/25 1485

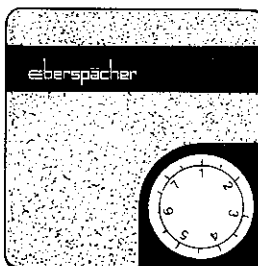

<b>18</b>	<b>1</b>	<b>Room thermostat</b> Cat. No. black 25 1557 80 01 00 brown 25 1557 80 07 00
-----------	----------	-------------------------------------------------------------------------------------

## Scope of delivery

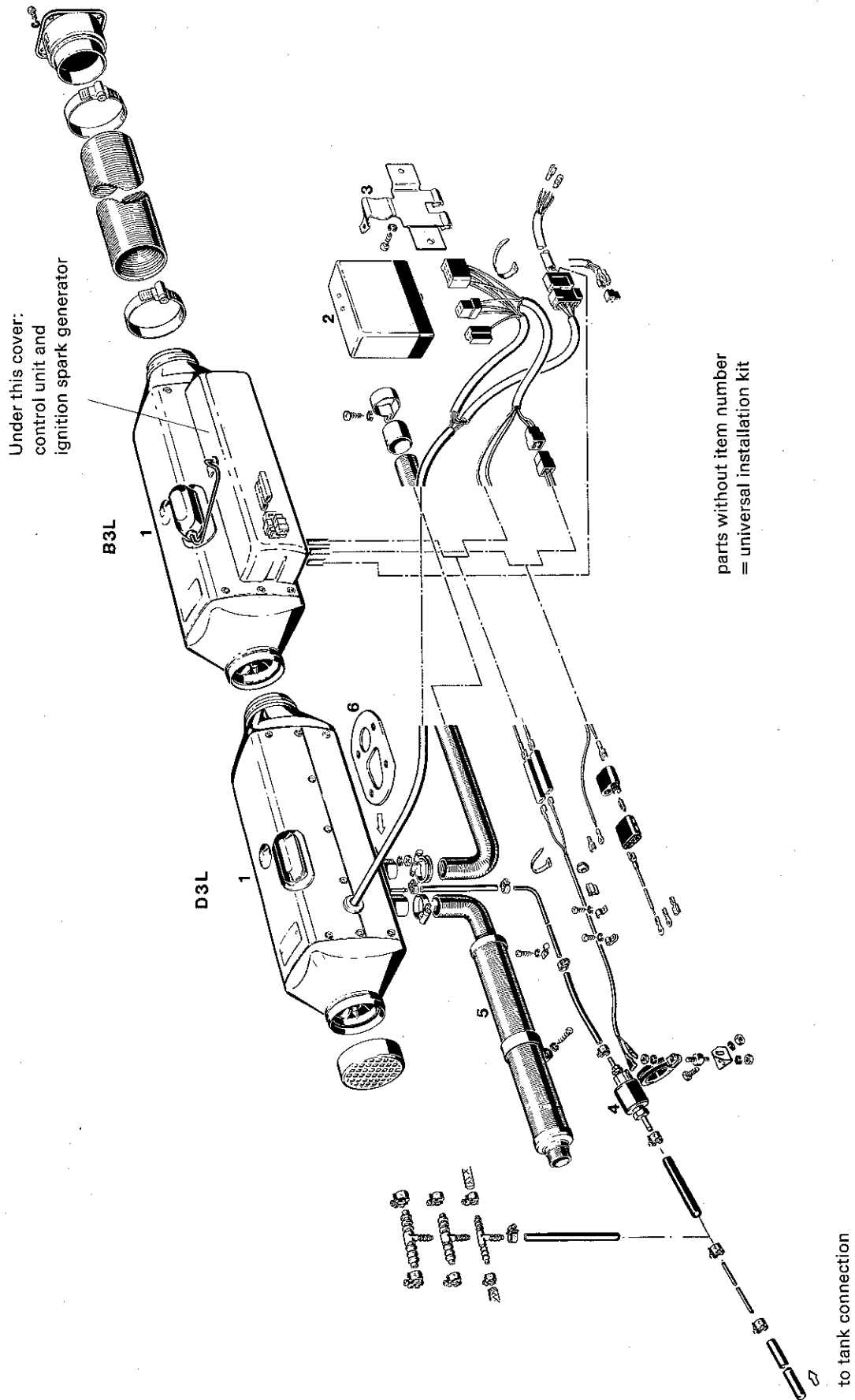

## Installation Instructions

The suggestions put forward in these installation instructions are only examples. Possibilities other than those illustrated (e.g. with regard to the choice of installation location, means of running air) are also permissible, provided they meet the requirements of the West German road traffic regulations (StVZO), and if necessary after consultation with the manufacturer.

### Approval, official regulations, general

1. For vehicles registered in West Germany (subject to the road traffic regulations StVZO), the heaters are approved by the Federal Motor Vehicle Office and receive an official test symbol (B3L  $\mathcal{W}$  S188, D3L  $\mathcal{W}$  S177) indicated on the name plate).

The year of first operation is a requirement of German approval not representing a model number.

2. If the heater is installed in special-purpose vehicles (e.g. vehicles transporting dangerous cargoes), the regulations applicable to such vehicles must be observed.
3. The heater must not be operated in closed rooms, e.g. garages.  
The heater must always be switched off when the petrol tank is to be filled.
4. The heaters must be installed by a workshop approved by the manufacturer and in compliance with the installation instructions.
5. The heaters may only be used for the purpose specified by the manufacturer and in compliance with the operating instructions supplied with every heater.

Operating the heater is not permitted where inflammable vapours or dust can build up (e.g. near fuel, coal or sawdust stores, grain silos etc.).

6. The proposed installations in the installation instructions are only examples. Other installation locations are also permissible, provided they comply with the general installation requirements: the manufacturer should be consulted if necessary. In all other respects, differences from the installation instructions, particularly with regard to wiring (wiring diagrams), fuel supply, combustion air and exhaust ducts, and use of operating and control elements not supplied by the manufacturer, are only permissible with the written approval of the manufacturer. Failing that, the manufacturer's warranty is null and void for the entire heater system, as is the general operating permit.
7. Every combustion process generates exhaust gas, which has toxic constituents. Because of this and the high temperatures generated, the exhaust duct must comply without fail with the installation instructions. Failure to comply with the instructions or operation of the heater in closed rooms (garages) harbours the risk of poisoning.
8. When the heater or the heating system is damaged, an authorized workshop must be called in to repair the damage in an expert manner and using genuine spare parts.  
Makeshift repairs (on one's own initiative) or the use of non-genuine spare parts are dangerous, and therefore not permitted. When carried out in cars, they invalidate the general design approval of the heater and consequently the general permit of the vehicle.
9. The warranty conditions are set forth in the heater booklet given to you by the after-sales service workshop when the heater is installed. Only our warranty conditions shall apply.

## Typical installations/installation location

### In truck:

D 3 L

1. on the rear wall of the cab
2. under the seat of the driver or co-driver

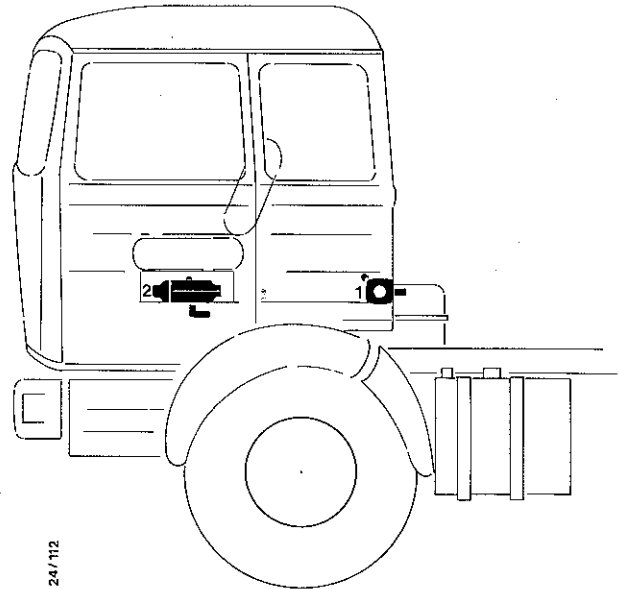

### In excavator:

D 3 L

in the cab

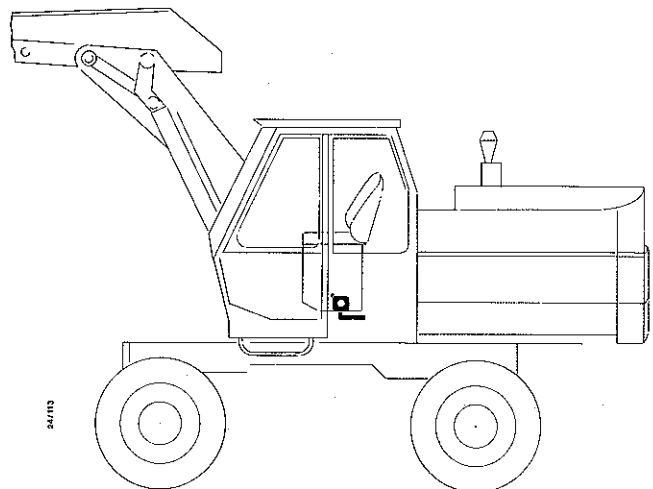

In van: B 3 L or D 3 L

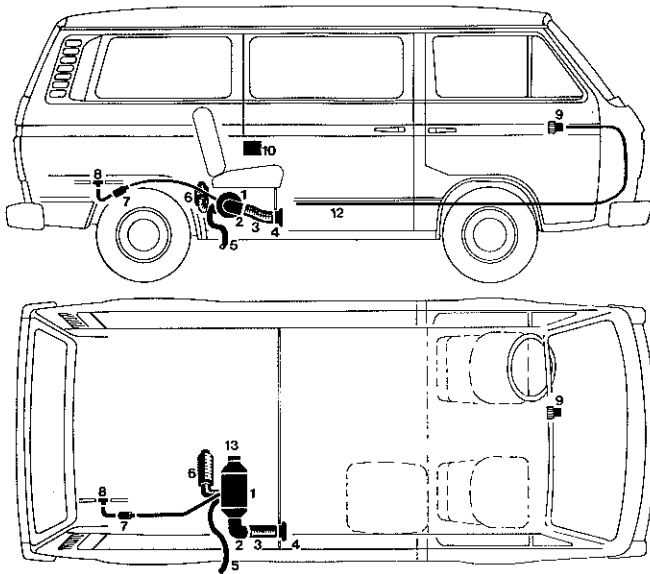

- 1 Heater
- 2 Pipe bend
- 3 Flexible pipe
- 4 Air outlet, rotatable
- 5 Flexible exhaust pipe
- 6 Intake silencer
- 7 Metering pump
- 8 Fuel branch
- 9 Universal switch
- 10 Room thermostat
- 12 Control cable
- 13 Protective grid

## Installing the heater

The B 3 L and D 3 L heaters are suitable and approved for installation in vehicle areas used by passengers.

In the case of installation in passenger areas, the exhaust, combustion air and fuel lines in these areas must not have any detachable connections, and must be splash-water-tight at the penetrations to the outside.

For this reason, the heater must be mounted by its base on an outside panel of the vehicle or on its floor, using the seal seated on the base.

**Principal dimensions of B 3 L and D 3 L.** Differing dimensions of B 3 L shown by dotted line.

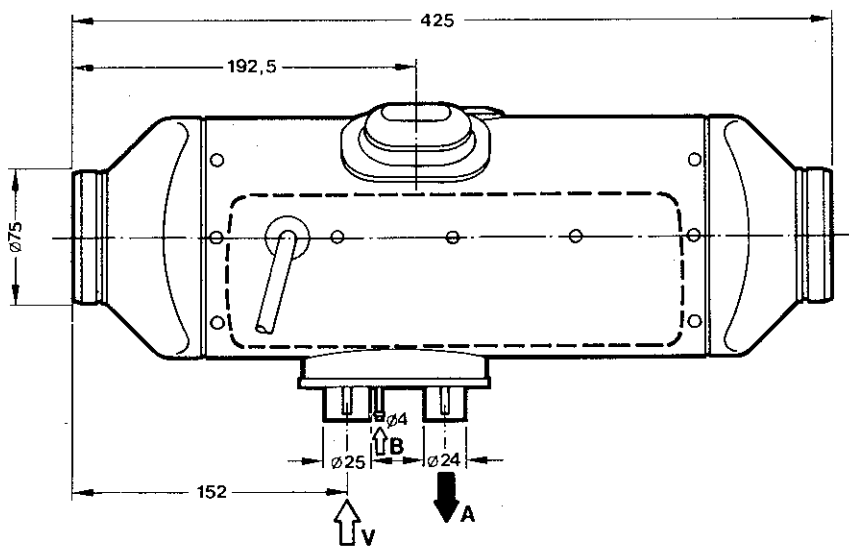

V = combustion air    A = exhaust    B = fuel

**Free space for fitting spark plug**

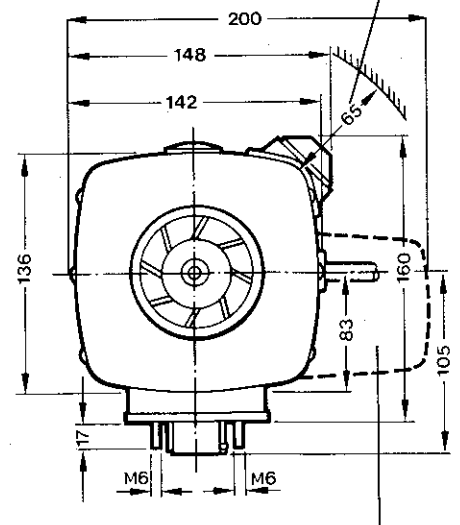

Control element can also be mounted separately or on the other side of the heater.

## Permissible installation positions

B 3 L and D 3 L  
either

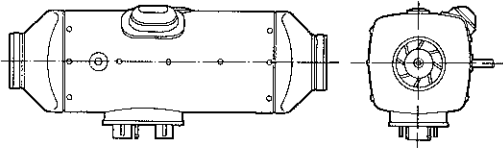

D 3 L only  
or

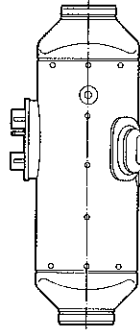

or

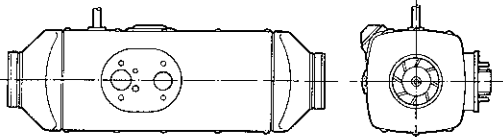

Installation should generally speaking be in the standard position, as illustrated.

If this is not feasible, please consult the manufacturer.

During starting and thermostatic operation, a heater installed in the standard position may deviate, due to the inclination of the vehicle during motion, by up to  $\pm 15^\circ$  in both axes from this standard position.

Continuous heating operation after starting is even possible at a deviation from the standard position of up to  $\pm 30^\circ$ . With deviations exceeding  $\pm 30^\circ$  a reliable continuous heating operation is no longer possible. This does not however lead to damage of the heater if the deviation occurs only for a short interval.

## Fastening to the vehicle wall/floor

Make penetrations in accordance with the hole pattern.

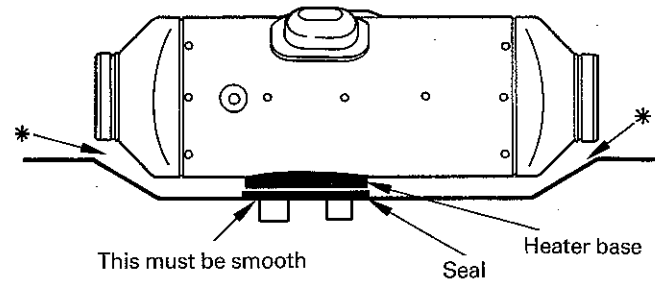
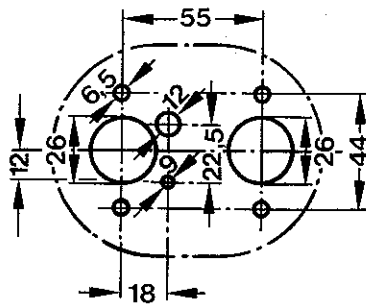

\* This must be kept free. Check for free running of fan wheel.

The mating surface for the heater base must be smooth. To drill the penetrations and if necessary to smooth the mating surface, a special tool is available from the manufacturer under Cat. No. 99 1201 46 53 29.

If the mating surface sheet is too thin (criterion: less than 1.5 mm), a reinforcing plate – Çat. No. 201577 89 00 03 can be installed additionally on the outside.

Special tool

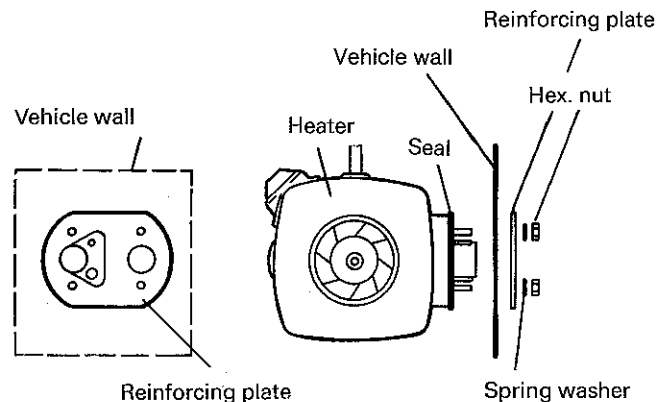
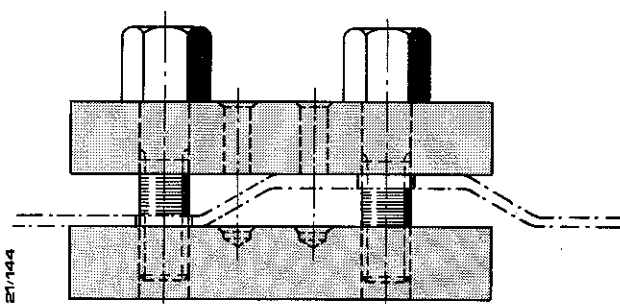

## Running the heating air

Standard heating air running parts. See Additional Equipment Catalogue for further parts.

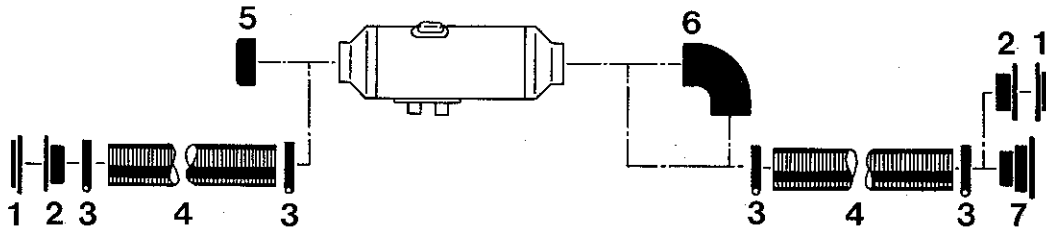

Item	Designation	Component rating	Cat. No.
1	Protective grid, round, nickel-plated	0.4	25 1226 89 05 00
2	Connection piece, 75 mm dia.	0.2	25 1226 89 00 12
3	Hose clip, 70–90 mm dia.	–	10 2064 07 00 90
4	Flexible pipe, 75 mm dia., lin. m	1.0 per lin. m.	10 2114 34 00 00
5	Protective grid, 75 mm dia.	2.0	25 1482 80 05 00
6	Pipe bend, 75 mm dia.	3.0	25 1482 80 00 05
7	Air outlet, rotatable, 75 mm dia.	1.0	22 1050 89 21 00
–	Pipe bend, 90°, of flexible 75 mm dia. pipe	1.0	

Do not connect too many parts. The sum of the component ratings may not exceed the heater rating.

### Example:

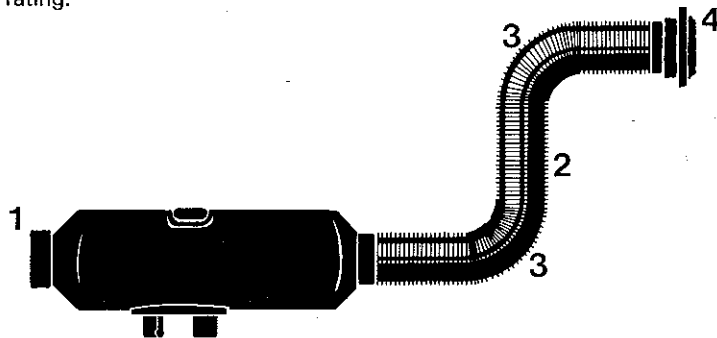

Item	Designation	Heater rating	
–	D 3 L/B 3 L heater	10	
Item	Designation	Component rating	Cat. No.
1	Protective grid, 75 mm dia., painted	2	25 1482 80 05 00
2	Flexible pipe, 75 mm dia., 4 lin. m.	4	10 2114 34 00 00
3	2 x 90° flexible pipe bends	2 x 1 = 2	
4	Air outlet, rotatable 75 mm dia.	1	
Sum of component ratings		9	

The sum of the component ratings does not exceed the heater rating of 10, installation is therefore permissible.

When checking an installation, the average outlet temperature should not at the outlet point significantly exceed 110°C with an intake temperature of 20°C. This will ensure that the safety thermal cutout switch will not respond under normal operating conditions.

Heating air intake openings shall be arranged in such a manner that exhaust from the vehicle's engine and from the heater cannot be expected to be sucked in under normal operating conditions, and the heating air cannot be contaminated.

When operating as a recirculating heater, locate the inlet for the heating air in such a way that the outflowing hot air cannot be sucked directly in again.

## Running the Combustion and Exhaust Air

Permissible diameters, lengths and bends of combustion air and exhaust lines

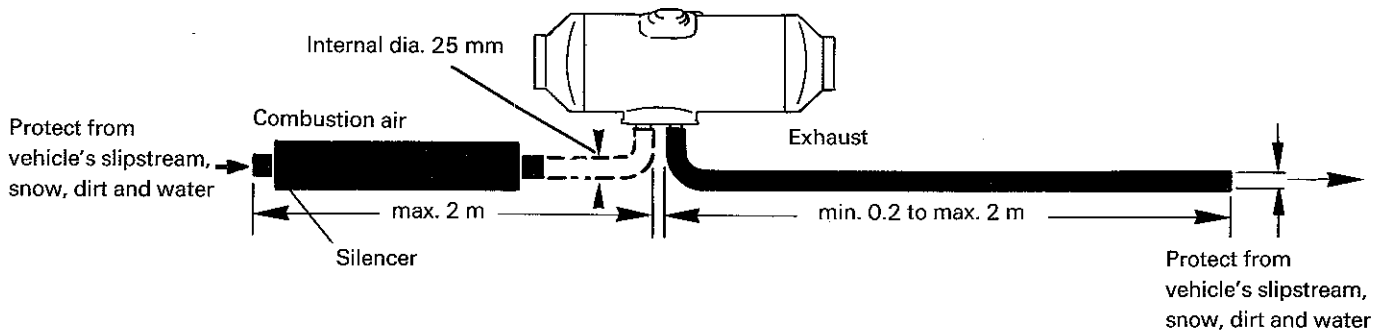

Permissible bends: exhaust line max. 180°; combustion air line max. 180°

The scope of delivery includes a flexible exhaust tube, internal dia. 24 mm, 1 m long, which can be shortened as required. Longer tubes are available as given in the Additional Equipment Catalog.

The intake silencer supplied with the heater must be employed at least. Extension to a total of 2 m (including silencer) is permissible.

The silencer must then be fitted on the free end of the extension.

Additional noise suppression is possible by installing an exhaust silencer (see chapter "Exhaust Parts" in the Additional Equipment Catalog). The permissible length of the exhaust line is reduced here by the length of the exhaust silencer.

**The combustion air must be sucked in from the outside, not from the passenger compartment or trunk.**

Do not install the intake opening facing the slipstream, but run it in such a manner that dirt and snow cannot enter and that any water which does enter can flow out.

Exhaust lines must not project beyond the sides of the vehicle. They must be laid either with a slight slope or with 5 mm dia. holes at the lowest points for draining off condensate.

It must not be possible to suck in the exhaust through the combustion air blower.

The exhaust outlet must be on the outside. Exhaust lines must be laid in such a way that neither the penetration of exhaust into the vehicle interior nor the intake of exhaust through the vehicle or heater blowers need be expected<sup>1)</sup>, and that the operation of essential vehicle parts is not affected (ensure adequate clearance). Place the outlet opening of the exhaust line in such a way that it cannot be clogged by dirt and snow and that any water which does enter can run off.

<sup>1)</sup> This requirement can be considered met if the outlet opening of the exhaust line is located at the usual places in motor vehicles (see examples on pages 4,5), e. g. in engine compartment, in wheel case, on the vehicle underside, or on the rear of the cab.

## Fuel supply

The instructions given here should not be disregarded as deviations may cause malfunctions.

### 1. Fuel intake from fuel line to engine (usually in passenger cars):

Precondition: the fuel line from the fuel tank to the engine must be tight, so that the flow of fuel is not interrupted when the engine is not running.

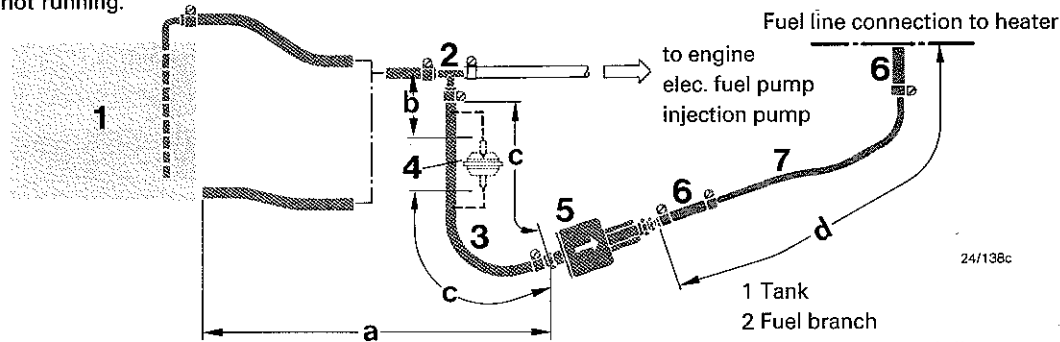

24/138c

Dimension a – max. 750 mm for gasoline  
max. 2000 mm for diesel oil

Dimension b – 50 mm

Dimension c – max. 300 mm

Dimension d – max. 4 m for gasoline  
max. 6 m for diesel oil

At all joints, fuel pipe (7) and connection pieces must touch.

- 1 Tank
- 2 Fuel branch
- 3 Fuel tube, internal dia. 5 mm
- 4 Fuel pre-filter (vertical, up to 30° downward if fuel line is tapped)  
Cat. No. 25 1226 89 00 37, only necessary if fuel is contaminated
- 5 Fuel metering pump (15° to vertical, inclined upward)
- 6 Fuel tube, internal dia. 3,5 mm
- 7 Fuel pipe, plastic, internal dia. 1,5 mm
- 8 Tank connection, internal dia. 2 mm
- 9 Tube or plastic pipe (max. internal dia. 5 mm)
- 10 Fuel pipe, plastic, internal dia. 2 mm

### 2. Fuel intake separately from fuel tank or separate tank (usually in trucks, construction machinery, agricultural machinery)

A = intake from above

B = lateral intake at tank

C = lateral intake at tank or beneath it, metering pump below lowest fuel level

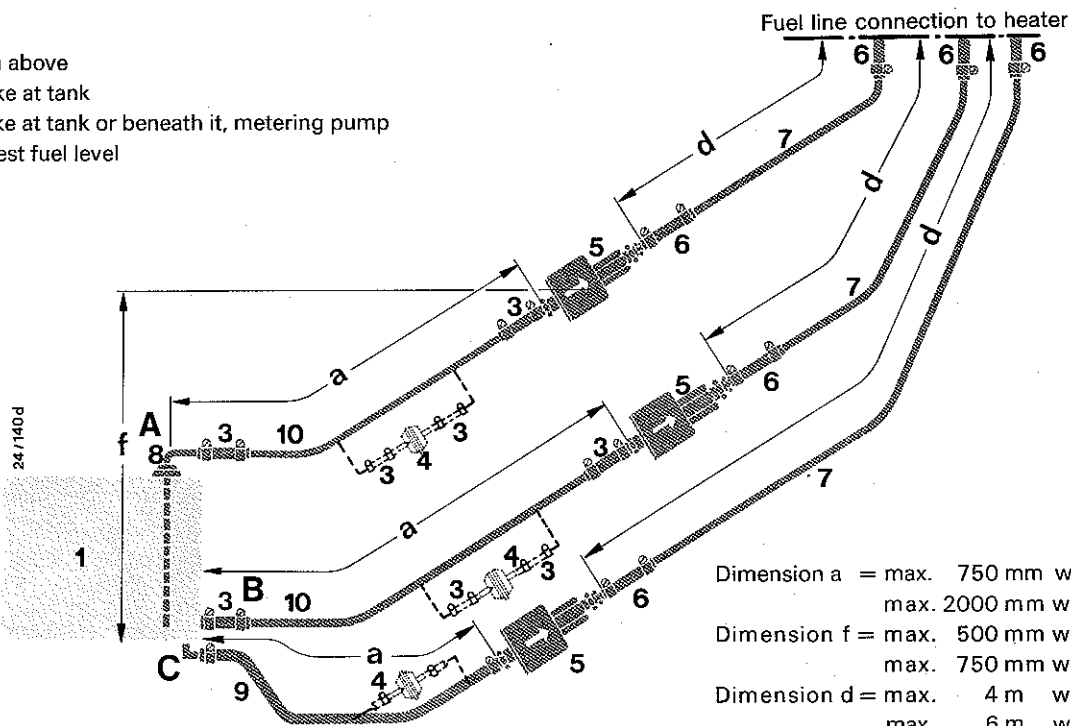

- Dimension a = max. 750 mm with gasoline  
max. 2000 mm with diesel oil
- Dimension f = max. 500 mm with gasoline  
max. 750 mm with diesel oil
- Dimension d = max. 4 m with gasoline  
max. 6 m with diesel oil

With connection types A and B, the intake line – A includes tank connection (8) – including all connection points must have an internal dia. of 2 mm, for this reason, fuel pipe (10) and connections must touch each other at every joint.

**3. Permissible suction and pressure heads for installation per 1. and 2.; permissible positioning of metering pump**

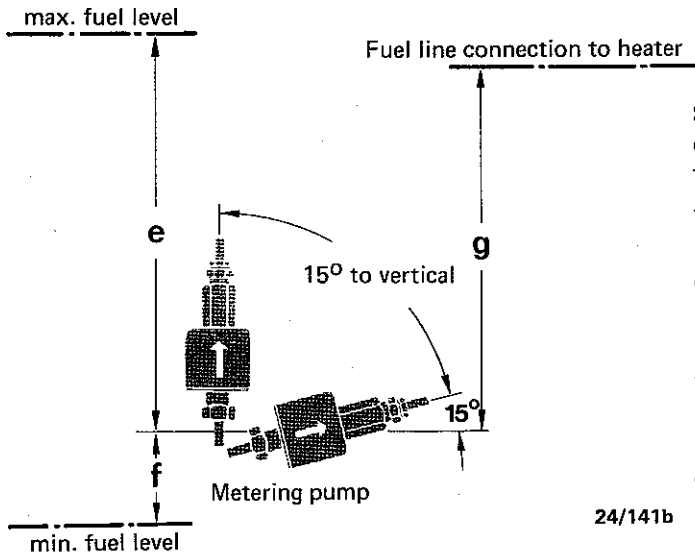

Supply pressure from tank to metering pump:

e = max. 3000 mm suction head:  
tank at zero pressure

f = max. 500 mm with gasoline  
max. 750 mm with diesel oil

Check whether tank ventilation works properly

intake from tank when underpressure occurs during operation  
(valve 0.03 bar in tank cap)

f = max. 150 mm with gasoline  
max. 400 mm with diesel oil

Pressure head metering pump to heater:

g = max. 2000 mm

24/141b Fuel line metering pump to heater should not have a slope if at all possible.

**4. Important**

Protect fuel lines, filter and metering pump from overheating; do not install near silencers and exhaust pipes. Temperatures above 30° C lead to gas bubbles and problems with gasoline.

When installing the fuel line, fuel filter and fuel metering pump near the rear axle, be sure to take the spring deflection of the rear axle into consideration.

Cut fuel tubes and pipes to length only with a sharp knife. Cuts may not be indented and must be burr-free.

For connection of the fuel branches, always use rubber tubing, never plastic pipe.

Fuel pipes connected by means of a fuel tube.

Fuel pipe sections must abut.

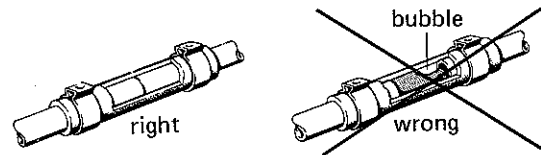

Do not let fuel tube sag.

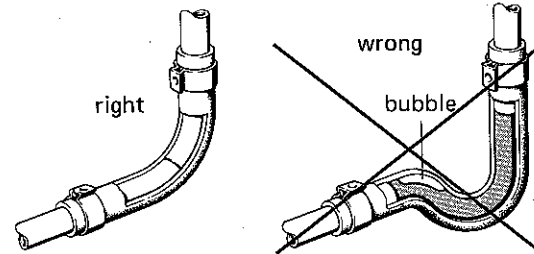

**Fuel grades**

**Fuel of D 3 L at low temperatures**

The heater can take without problem the fuel you use in your tank and which is commercially available. In the USA diesel fuel no. 1 and no. 2. Admixture of used oil is not permitted.

The refineries automatically adapt their fuels to normal winter temperatures (Winter Diesel).

Therefore difficulties can only arise at extremely low temperature (as in the engine – see the vehicle's instruction manual).

If the heater is operated from a separate tank, the following rules must be observed: at temperatures above 0° C any type of diesel fuel can be used.

If no special cold-weather diesel fuel is available at low temperatures, mix kerosine or gasoline according to the adjacent table.

Temperature	Winter diesel fuel	Additive
0° to -15°C**	100%	—
-15° to -25°C	50%	50% Petroleum or petrol
-25° to -40°C	—	100% Petroleum*

\* or special winter diesel fuels.

\*\* or in accordance with fuel manufacturer's specifications.

The fuel line and the fuel pump must be filled with new fuel by operation for 15 minutes.

**Fuel for special cases**

In special cases, the heaters can also be operated with extra-light fuel oil (above 0° C) or petroleum. If in doubt, please consult the manufacturer.

## Electrics

Arrange electric cables, switches and control units in the vehicle in such a way that their correct functioning cannot be impaired under normal operating conditions.

Fit the control unit so that it is protected from splash water (from both its own vehicle and preceding ones). Outside installation is thus not permissible. The unit is best arranged in the vehicle interior, with the plugs pointing downward.

Control unit  
Permissible installation angles

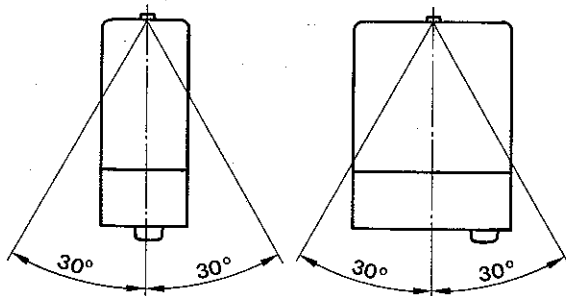

The pilot light (built into the switch or timer) should be within the field of vision of the driver, or at least be visible to him without great effort.

Install the room thermostat where it is sheltered from draughts and sunlight. Do not fit it to non-insulated outer walls.

The following cable cross-sections must be observed between battery and heater, in order that the maximum permissible voltage losses in the cables (0.5 at 12 V rated voltage and 1 V at 24 V) are not exceeded.

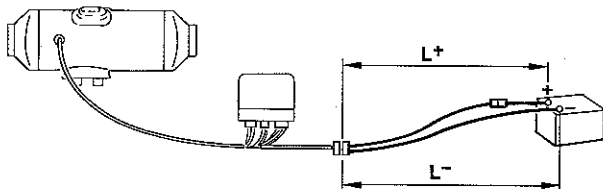

$L^+ + L^- < 5 \text{ m} \rightarrow$  cross-section  $4 \text{ mm}^2$

$L^+ + L^- 5 \text{ to } 8 \text{ m} \rightarrow$  cross-section  $6 \text{ mm}^2$

If the plus cable is to be connected to the fuse box (e.g. terminal 30), the vehicle's cable too from the battery to the fuse box must be included in the calculation of the total line length, and if necessary redimensioned in accordance with the above.

Smear plug and earth connections with contact protection grease outside the vehicle interior.

Wiring diagram D 3 L - 12 V - design 25 1482

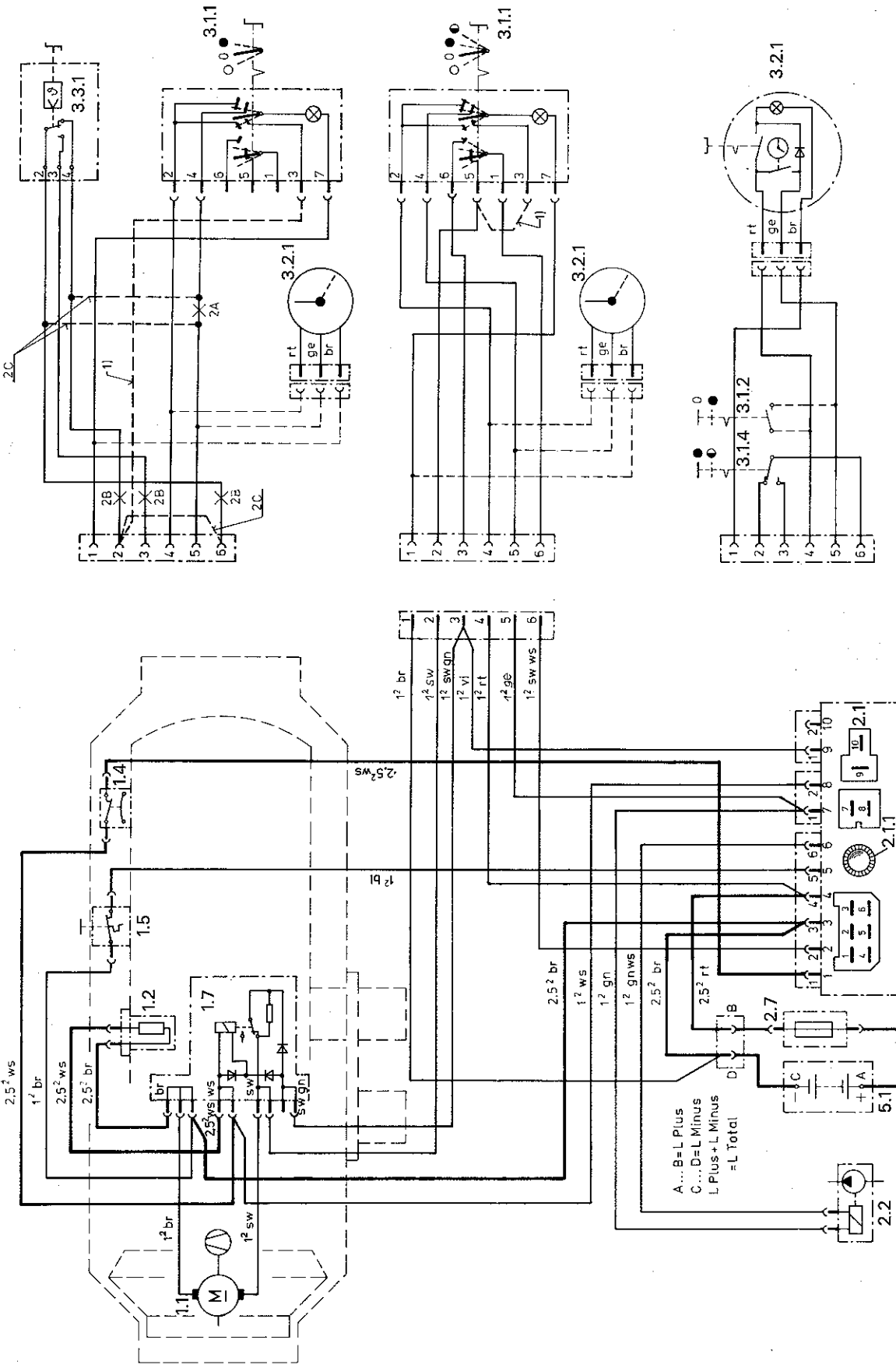

Parts list

- 1.1 Burner
- 1.2 Glow plug
- 1.4 Temperature switch
- 1.5 Safety thermal cutoff switch
- 1.7 Printed circuit board
- 2.1 Control unit
- 2.1.1 Motor fuse
- 2.2 Fuel metering pump
- 2.7 Main fuse, 16 A
- 3.1.1 Universal switch
- 3.1.2 Continuous operation switch
- 3.1.4 Additional Full-Half switch
- 3.2.1 Timer
- 3.3.1 Room temperature controller
- 5.1 Battery

Connection of room thermostat:  
"Full-Half" operation illustrated.

Proceed as follows for connection of "On-Off" operation:

- 2 A Break cable
- 2 B Cable not required
- 2 C Connect cables

1) Connect this cable for fan operation

Sp 25 1482 01 96 01 9

## Wiring diagram D 3 L - 24 V - design 25 1483 and 25 1573

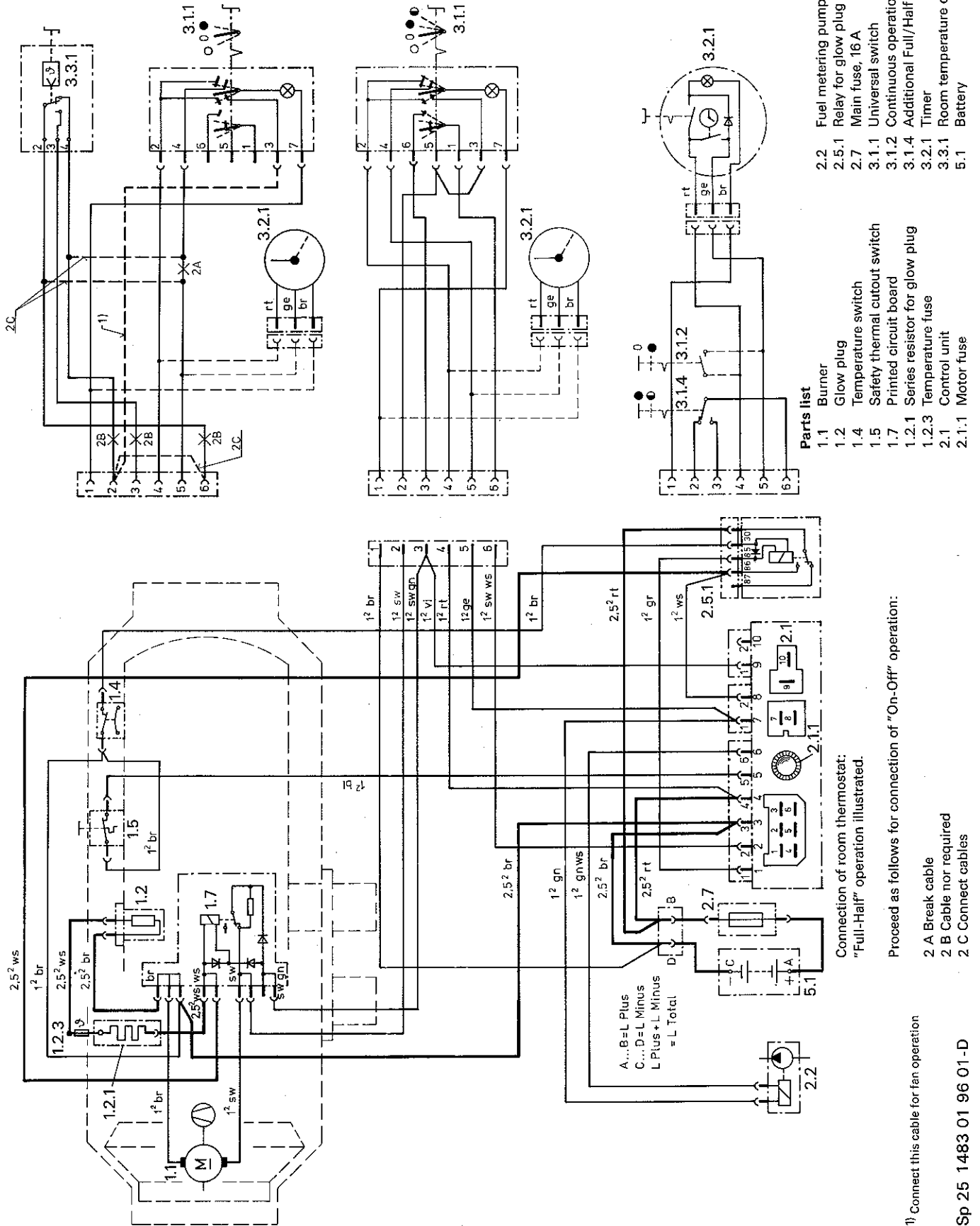



Wiring diagram D 3 L – 24 V – design 251641 / 251642

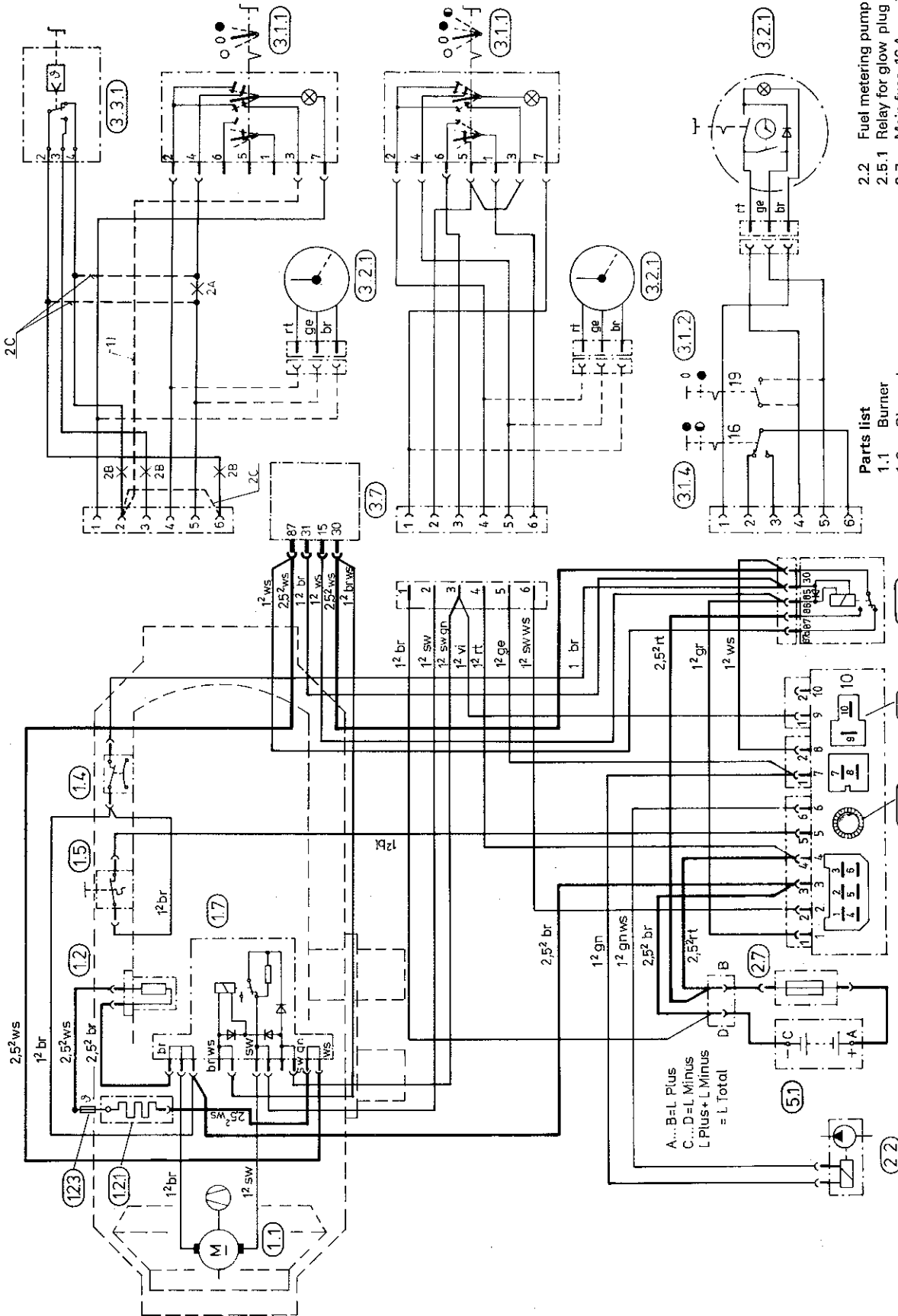

- Parts list**
- 1.1 Burner
  - 1.2 Glow plug
  - 1.4 Temperature switch
  - 1.5 Safety thermal cutout switch
  - 1.7 Printed circuit board
  - 1.2.1 Series resistor for glow-plug
  - 1.2.3 Temperature fuse
  - 2.1 Control unit
  - 2.1.1 Motor fuse
  - 2.2 Fuel metering pump
  - 2.5.1 Relay for glow plug
  - 2.7 Main fuse, 16 A
  - 3.1.1 Universal switch
  - 3.1.2 Continuous operation switch
  - 3.1.4 Additional Full/Half switch
  - 3.2.1 Timer
  - 3.3.1 Room temperature controller
  - 3.7 Glow plug current regulator
  - 5.1 Battery

1) Connect this cable for fan operation

Connection of room thermostat:  
 "Full-Half" operation illustrated.  
 Proceed as follows for connection of "On-Off" operation:

- 2 A Break cable
- 2 B Cable not required
- 2 C Connect cables

Wiring diagramm B 3 L - 12 V - design 20 1643

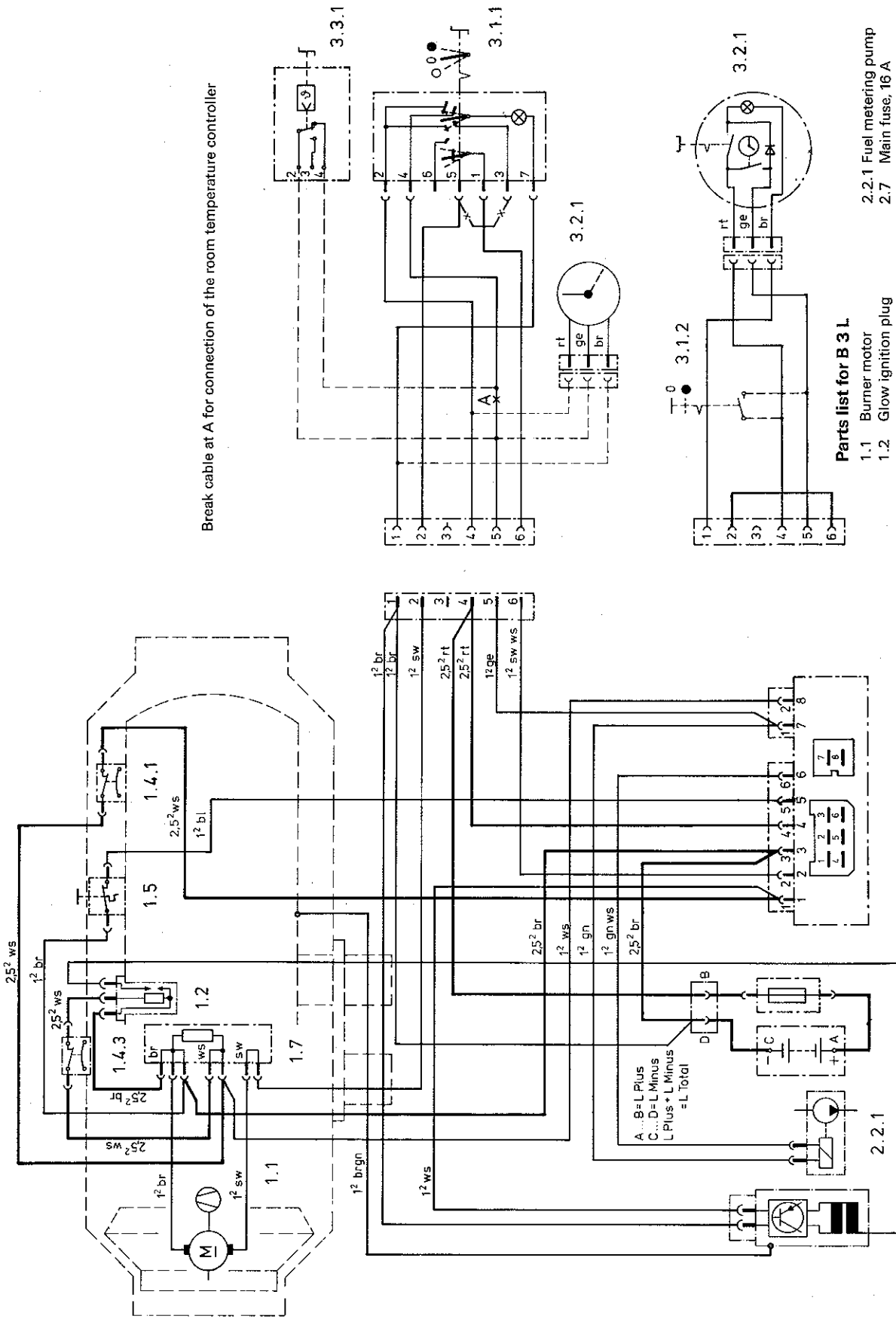

Break cable at A for connection of the room temperature controller

Parts list for B 3 L

- 1.1 Burner motor
- 1.2 Glow ignition plug
- 1.3 Ignition spark generator
- 1.4.1 Temperature switch
- 1.4.3 Heating coil switch
- 1.5 Safety thermal cutout switch
- 1.7 Distributor strip
- 2.1 Control unit
- 2.1.1 Motor fuse
- 2.2.1 Fuel metering pump
- 2.7 Main fuse, 16 A
- 3.1.1 Universal switch (x - x - x - for "Ventilation" operation)
- 3.1.2 Heating switch (continuous operation)
- 3.2.1 Timer
- 3.3.1 Room temperature controller (break cable at A to connect)

Sp 20 1643 00 96 01-C

## Description of operation (see page 16 for text)

D 3 L: shown complete

B 3 L: differences shown in inset

additional housing (12c) with control unit (12a) and ignition spark generator (12b) for the ignition plug

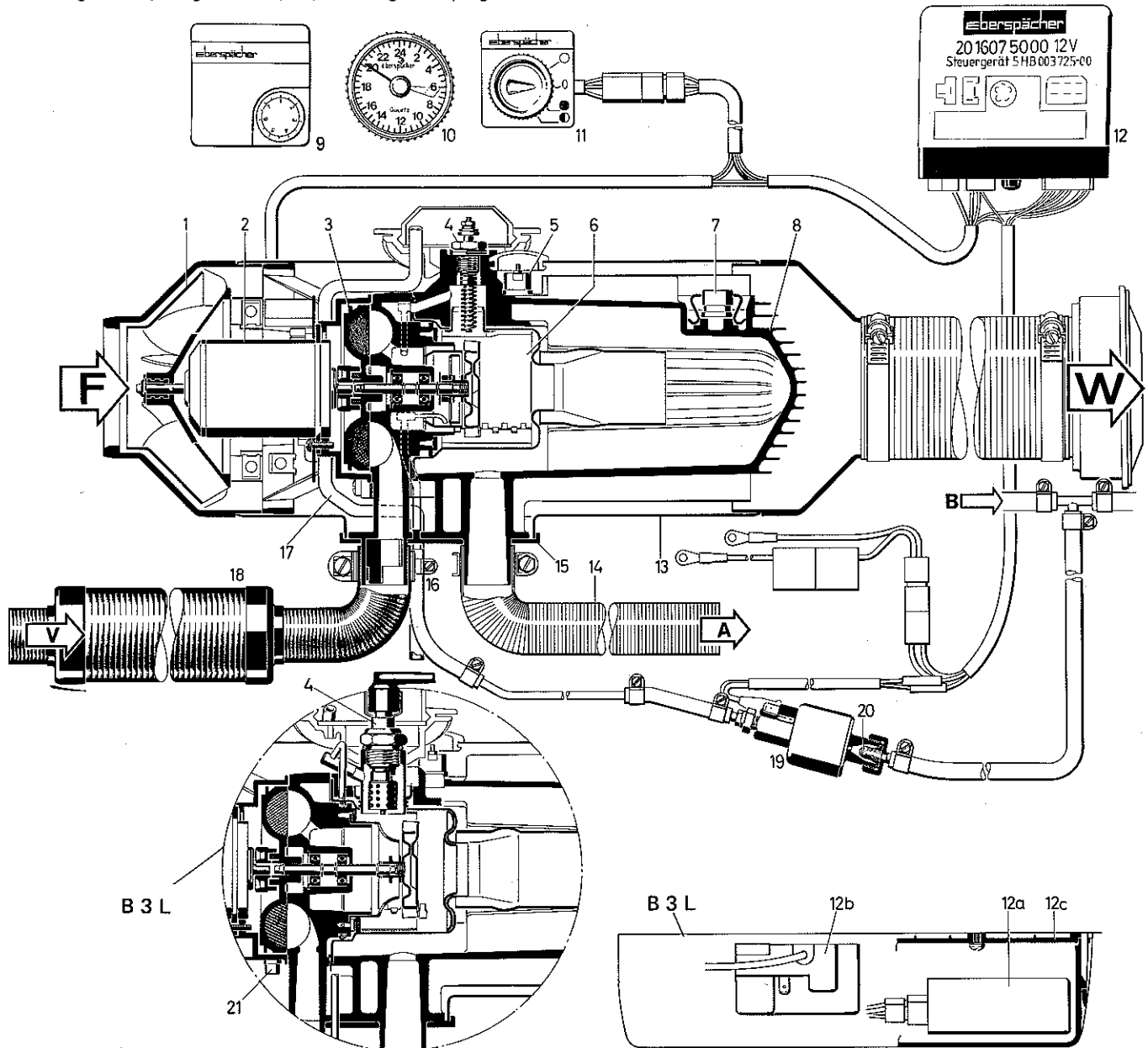

- 1 Fresh air blower wheel
- 2 Electric motor
- 3 Combustion air blower wheel
- 4 Glow plug: D 3 L  
Glow ignition plug: B 3 L
- 5 Safety thermal cutout switch
- 6 Combustion chamber
- 7 Temperature switch
- 8 Heat exchanger
- 9 Room thermostat
- 10 Timer
- 11 Universal switch
- 12 Control unit: D 3 L for  
"Full-Half" operation

- 12a Control unit: B 3 L
- 12b Ignition spark generator: B 3 L
- 12c Housing: B 3 L
- 13 Casing
- 14 Exhaust pipe
- 15 Connecting flange
- 16 Fuel connection
- 17 Plug area ventilation
- 18 Combustion air silencer
- 19 Fuel metering pump
- 20 Cup sieve built into  
fuel metering pump
- 21 Heating coil switch: B 3 L

## Description of operation (see Fig. on page 17)

Heaters D 3 L and B 3 L are of identical design wherever practicable. However, as a result of the differing fuel types (diesel/gasoline) and, in the case of D 3 L, depending on whether "Full-Half" setting is required or not, design differences are unavoidable.

## Control elements (see also page 2)

The following can be used optionally in D 3 L and B 3 L:

1. Universal switch<sup>1)</sup> (11)  
B 3 L: Heating/Ventilation  
D 3 L: Heating Full/Half Ventilation
2. Timer (10)  
Using the timer, the heater can be switched on at once or preselected up to 22 hours prior to switch-on time.
3. Room thermostat (9)  
Operation with thermostat is also possible in conjunction with universal switch or timer. Please bear in mind the following:  
On-Off or Full-Half regulation is possible with D 3 L. See wiring diagram for connection. With On-Off operation, the burden on the battery is greater, and heavier wear on the plugs must be expected. With B 3 L, regulation is of the On-Off type, but a built-in heating coil switch (21) ensures that the heater coil stays off in short regulation periods, in which the ignition sparks are sufficient to create a flame. This means that the battery is not too heavily taxed and that the plug wear does not increase.

## Procedure after switching on:

After switching on, the pilot light in the switch or timer comes on, the heating air blower and the combustion air blower begin to produce heating air and combustion air respectively<sup>2)</sup>. At the same time, the fuel metering pump provides precisely measured amounts of fuel to the combustion chamber.

D 3 L: Fuel supplied to a rotating, open fuel distributor on the blower shaft

B 3 L: Fuel supplied to the glow ignition plug connections.

Fuel and combustion air form an inflammable mixture in the combustion chamber. This mixture is ignited by the glow plug (D 3 L) or glow ignition plug (B 3 L). The combustion gases flow through the heat exchanger and actuate the temperature switch, which then switches off the heating coil.

The heating air is warmed up by the heat exchanger and passes through the outlet into the area to be heated. The pilot light goes out when the heater is switched off, but the blower motor continues to run until the heater has cooled down. It is then switched off automatically by the temperature switch.

## Controls and Safety Equipment

The flame is monitored by the temperature switch. This switch acts on the safety switch in the control unit, which shuts down the heater in the event of a malfunction.

- a) The temperature switch switches off the glow plug after a stable flame has been obtained. In addition, after the heater has been switched off, it automatically stops the blower once the heater has cooled down.
- b) If the heater fails to ignite, it switches off automatically not more than 3 minutes after being switched on.  
If a defect in the blower motor has caused the heater to switch off, the motor current fuse installed in the control unit may have been tripped. Check it and replace if necessary. The heater can be switched back on by briefly switching it off and back on again. If the motor current fuse blows repeatedly, have the blower fault remedied.
- c) If the flame goes out spontaneously during operation, the heater is automatically switched off after 4 minutes at the most. Restarting is by switching off and back on.
- d) The safety thermal cutout switch shuts down the fuel pump when the heater overheats, e.g. in the event of the heating air ducts becoming blocked. The heater then switches off automatically.  
See under "Malfunctions" for switching back on.
- e) The glow plug monitor in the control unit – heaters D 3 L only – prevents fuel being pumped when the glow plug is defective and when the temperature fuse on the glow plug series resistor has blown (D 3 L 24 V only).
- f) Undervoltage safety device  
An undervoltage safety device built into the control unit switches off the heaters when the voltage at the control unit drops below approx. 10.5 V or 21 V, as the case may be.
- g) Overvoltage safety device  
In the case of B 3 L and D 3 L heaters, models 25 1484 and 25 1485, an overvoltage safety device built into the control unit switches off the heaters when the voltage at the control unit exceeds 15 V and 30 V respectively.

## Maintenance:

The heater should also be switched on briefly (about 10 minutes) once a month during the warm season.

## Malfunctions

You can remedy the following malfunctions yourself:

1. The blower cannot be heard after the heater is switched on:
  - a) Check the 16 A fuse in the cable harness of the heater;
  - b) Check the motor current fuse in the control unit.  
**Important:** Only the following Eberspächer spare part fuse inserts (special monitored design) may be used:  
for 12 V fuse insert TT4,  
blue marking, No. 460 26 016  
for 24 V fuse insert TT2,  
yellow marking No. 460 26 000  
The use of other fuse inserts may lead to damage to the heater in the event of a malfunction.
  - c) Check the glow plug, and replace it if necessary (D 3 L only).
  - d) Consult the workshop.
2. After the heater is switched on, the blower only runs for about 3 minutes, the heater does not ignite and is switched off automatically:  
Briefly switch the heater off and back on again (not more than twice). If the heater still does not ignite:
  - a) Check the glow plug, and replace it if necessary (B 3 L);
  - b) Have the trouble seen to in the workshop (B 3 L and D 3 L).
3. After the heater is switched on, the blower only runs for about 20 seconds, the heater does not ignite and is switched off automatically. Check battery voltage. If the voltage is less than 10.5 or 21 V respectively, the undervoltage safety device has been activated. Start the vehicle engine or charge the battery, then switch the heater off and back on again.
4. The heater goes out during operation:  
If the fault is due to overheating, switch the heater off, eliminate the cause of overheating (e.g. blocked heating air lines). Press the safety thermal cutout switch (1) through the rubber cap, switch the heater back on.

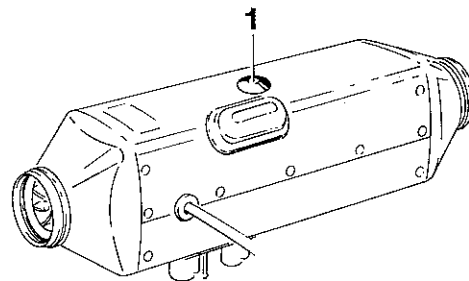

Remember that heaters D 3 L only start to work some 5 seconds after being switched on.

The pilot lamp in the universal switch comes on at once when the heater is switched on.

- 1) If other switches that are usual in motor vehicles are used, they should be able to take at least 10 A.
- 2) With heaters D 3 L the blower does not run until approx. 5 seconds after switch-on, and the fuel metering pump not until after approx. 25 seconds.