

# Boordnet VAART

Accu schema / Zonnepaneel schema / Walstroom schema  
Zie aparte pagina

1 2  
3 4  
5 6  
7 8  
9 10  
11 12

MIN = blauw en zwart  
PLUS = rood en bruin

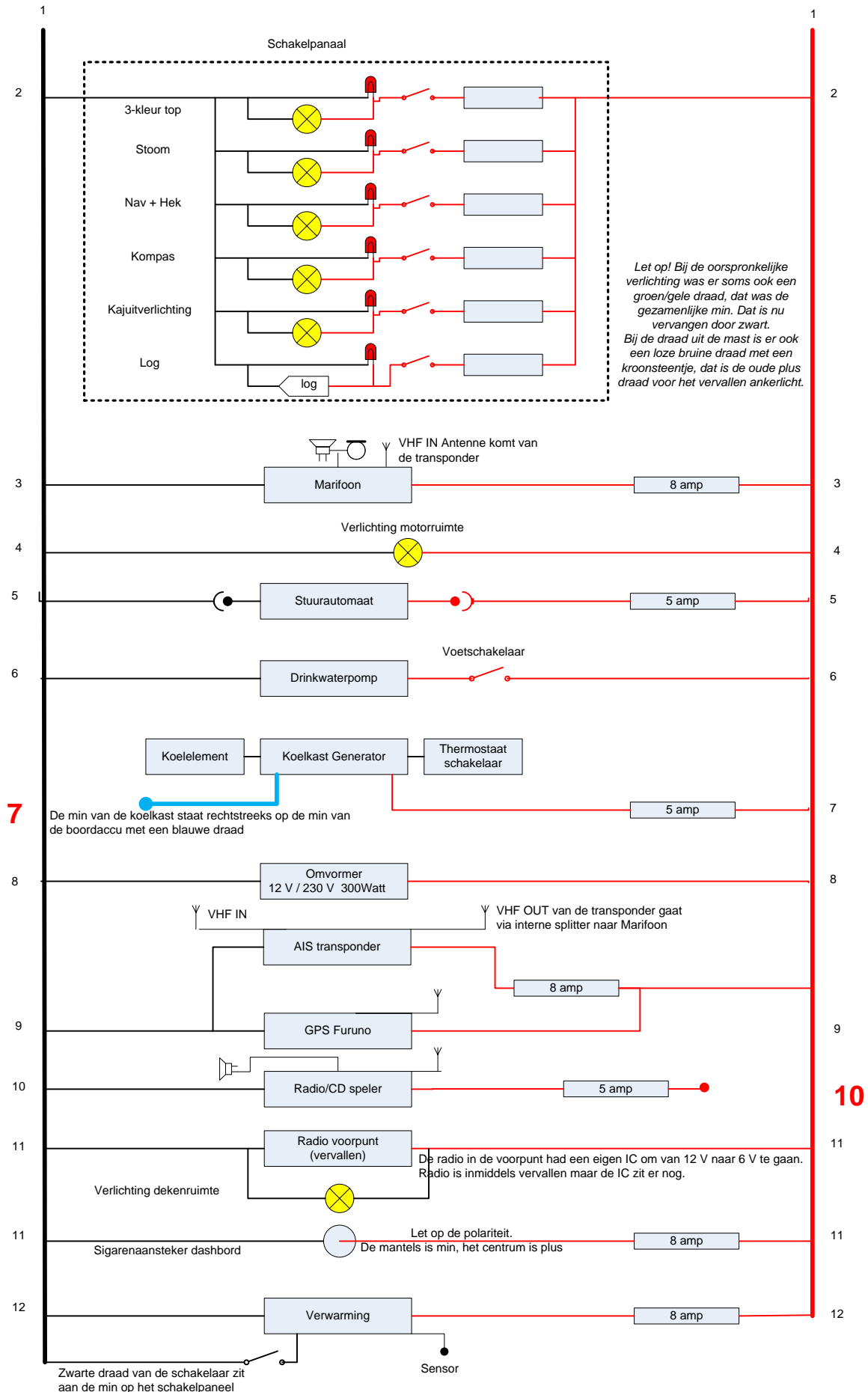

# Accuschema

## Zonnepaneel aansluiting

### Accu(-druppel)lader

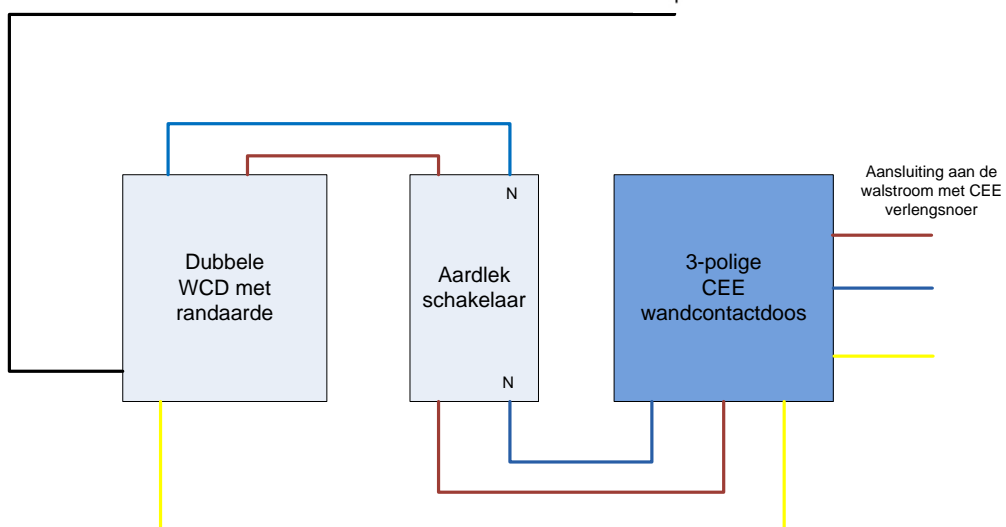
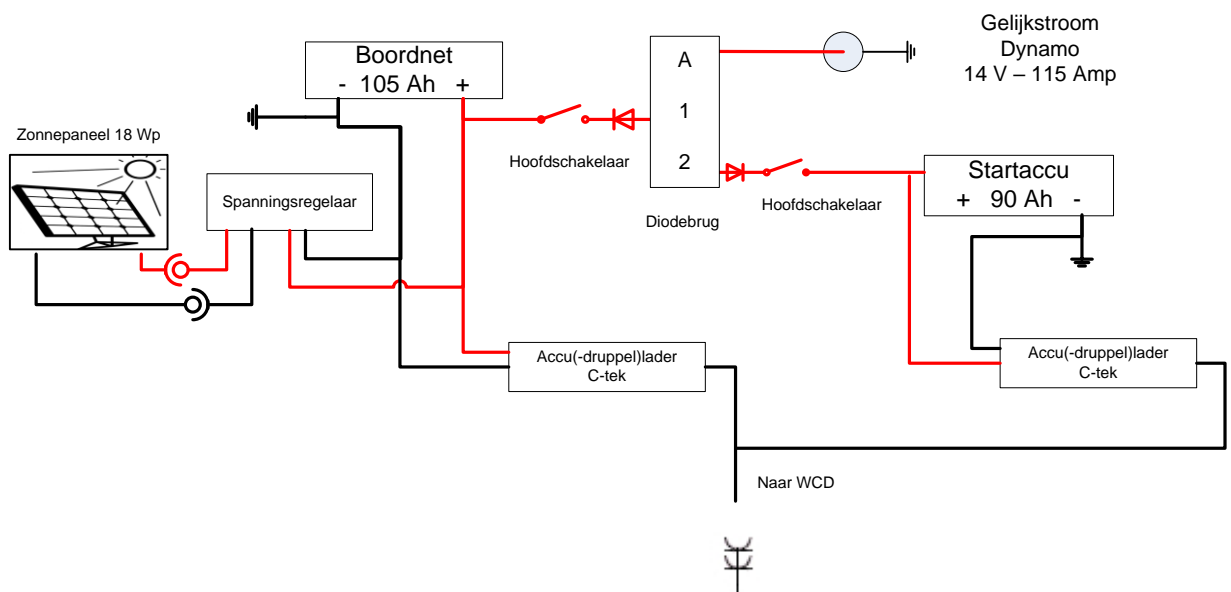

## Walstroom schema

# NMEA schema

Via Multiplexer van de  
Transponder

