

---

S E R V I C E M A N U A L

BOAT HEATER - MINIMAX

## Contents

<u>Page</u>	<u>Name</u>
1	General
1	Technical data
2	Design
3	Start of heater
4	Operation
5	Components
9	Electrical connections
10	Fault tracing
11	Fault tracing table
13	Repair instructions
19	Periodic overhaul
20	Drawing

## GENERAL

This service handbook is intended as a supplement to the instruction book supplied to the purchaser with the heater.

The service handbook is for use by the authorized workshops and provides more detail, especially in the section on fault tracing and repair.

The heater is designed to meet the present regulations for testing of boat heaters.

The heater has furthermore been given the following characteristics which are important for use in leisure boats, type sail or engine:

- low current consumption
- low internal and external sound level
- adjustable power

The MINIMAX boat heater is driven by Diesel oil and fed with 12 V or 24 V tension. Fresh air is warmed up and distributed to the cabin by means of hoses and other parts in the installation kit. This kit can be completed with other accessories as thermostat. (Operation of thermostat, see OPERATION.)

The heater is connected to the normal or a separate battery and to a separate supply unit.

## TECHNICAL DATA

Heating capacity	0,6 - 3,0 kW
Voltage	
Nominal	12 volt
Operation range	12 volt $\pm$ 15 %
Current consumption during operation	0,6 - 0,8 A
Current consumption at ignition (2 min)	4,5 A
Warm air quantity (without hoses)	110 m <sup>3</sup> /h
Fuel tupe*	Diesel oil or paraffin
Fuel consumption	0,08 - 0,35 l/h
Weight, heater unit	8,5 kg
Dimensions, heater unit	390 x 160 x 230 mm

\* The Diesel oil must be of such a quality that the turbidity point is not reached at the utilization temperature.

## DESIGN

The principal components are:

- Burner unit with glow unit and re-cooling thermostat
- Heat exchanger
- Fresh air fan and a overheating thermostat built-in into the outlet
- Combustion air fan
- Fuel pump
- Printed circuit card.

The following main components are seen outside the case:

- Control panel with cabling
- Outer cabling with current feed via fuse and earth connection
- Fuse box with switch for heat and ventilation and an adjustable control for heat effect.

The heater is operated by the control panel.

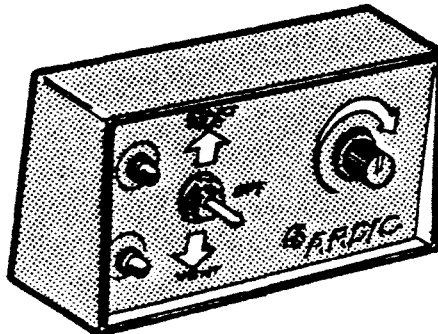

## DESIGN

The principal components are:

- Burner unit with glow unit and re-cooling thermostat
- Heat exchanger
- Fresh air fan and a overheating thermostat built-in into the outlet
- Combustion air fan
- Fuel pump
- Printed circuit card.

The following main components are seen outside the case:

- Control panel with cabling
- Outer cabling with current feed via fuse and earth connection
- Fuse box with switch for heat and ventilation and an adjustable control for heat effect.

The heater is operated by the control panel.

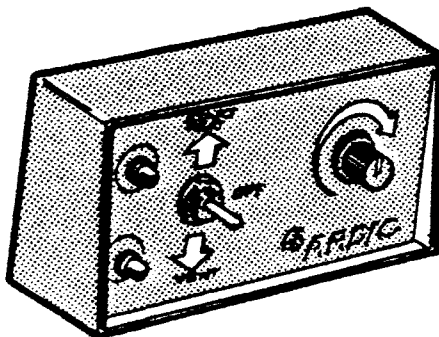

## START OF HEATER

N.B. ALWAYS REMOVE THE PROTECTION COVER FROM THE CHIMNEY BEFORE STARTING THE HEATER.

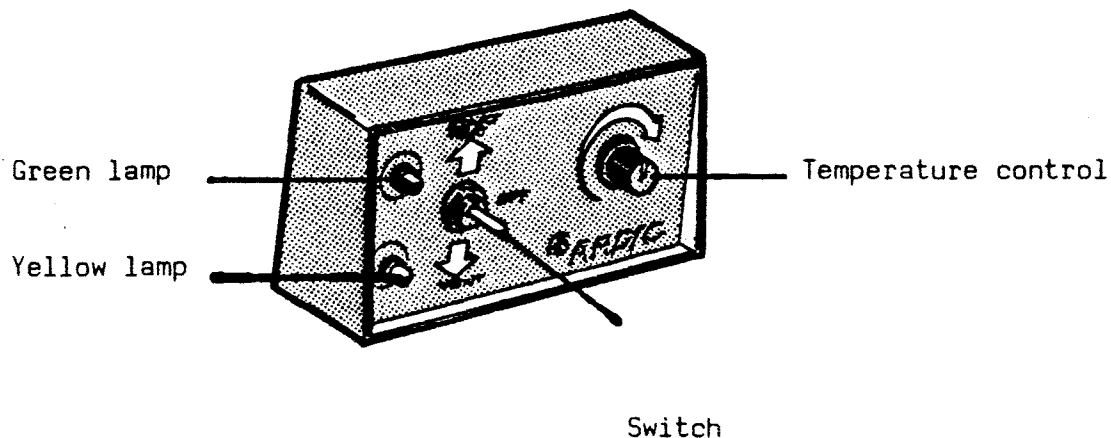

1. Set the switch on the control panel to position "START HEAT" (the green lamp goes on).
2. When the yellow lamps goes on (after about 5 - 10 minutes) the heater goes to the set position of the temperature control. (The heater output capacity can thus not be adjusted until the yellow lamps has gone on.)

N.B. At first start, or if the supply unit is empty, two start attempts may be necessary. The fuel pump will suck a fuel column of about 0,5 m/min, measured on the semi-transparent pipe in the kit.

## RE-START OF HEATER

1. When starting the heater before the yellow lamp has gone out, set the temperature control with the marking upwards.

## STOP HEATER

1. Set the switch in position "OFF". The fan will not stop until the heater as cooled down so that the re-cooling thermostat breaks the electric circuit and the yellow lamps has gone out.

THE HEATER MUST NOT BE SWITCHED OFF UNTIL THE YELLOW LAMP HAS GONE ON.

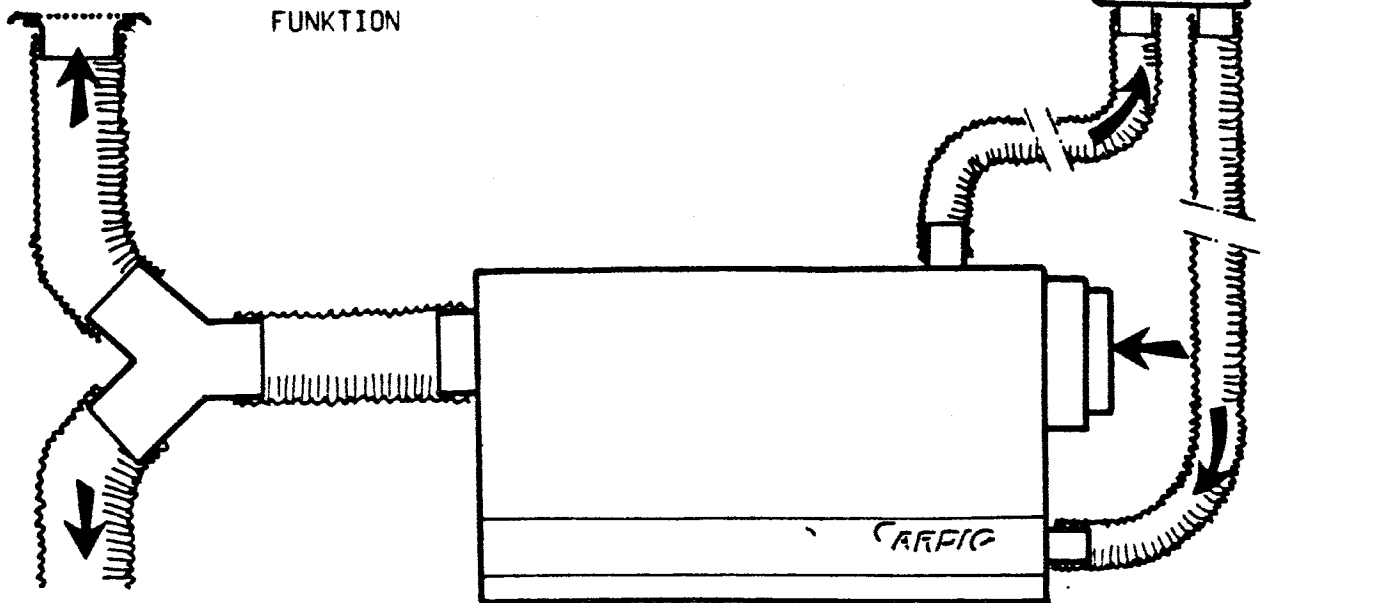

The heater is operated by the control panel, se "START OF HEATER".

When the heater is switched on (green lamps goes on), the fresh air fan, combustion air fan, fuel pump and glow unit are activated. The glow unit is switched off after about 2 minutes. The combustion starts and when the flame is sufficiently developed (about 5-10 minutes), the re-cooling thermostat cuts in (yellow lamp goes on).

The combustion gases passes the stainless heat exchanger and go out through the exhaust outlet.

The fresh air is sucked in by the fan motor and passes inside the heat exchanger, is heated and distributed in the boat.

The heater is continuously burning. Avoid switching on and off of the heater when it is being used.

The fan motor will continue to operate after switching off until the burner unit temperature has gone down and the yellow lamp has gone out.

N.B. The heater must not be switched off until the re-cooling thermostat has closed.

The heater must not be switched off with the main circuit breaker of the boat until the re-cooling thermostat has stopped the fan.

If the heated air temperature is too high, the overheating thermostat will break the current to the fuel pump. The overheating thermostat can after cooling be reset to closed position by pushing the centre button.

Glow unit

The glow unit is specially designed for the Mini-Max heater. The current consumption is about 4 A.

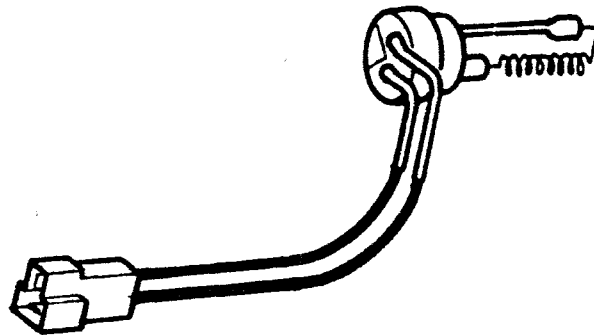

Heat exchanger

The heat exchanger is made of stainless steel and is a tight welded mantle with the exhaust outlet directed upwards.

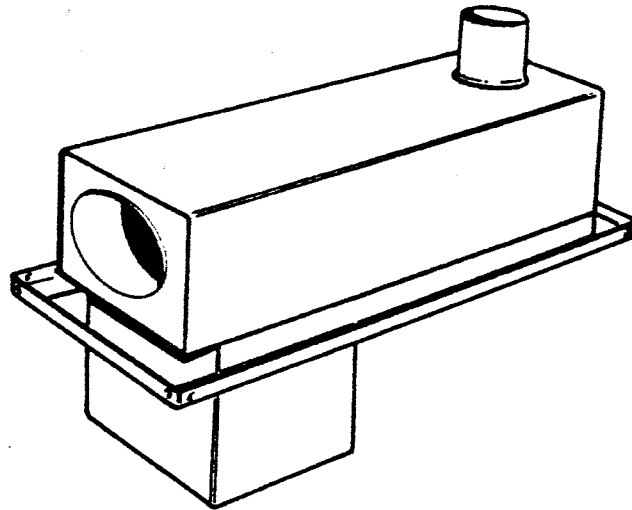

Fresh air fan - combustion air fan

The fans are silent high quality fans with low current consumption for the distribution of warm air and combustion air.

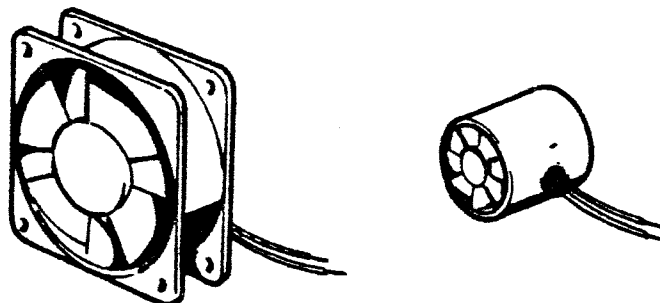

If the heater does not ignites at start, the safety circuit will stop the heater automatically after 15 - 20 minutes.

Connection of cabin thermostat (accessory)

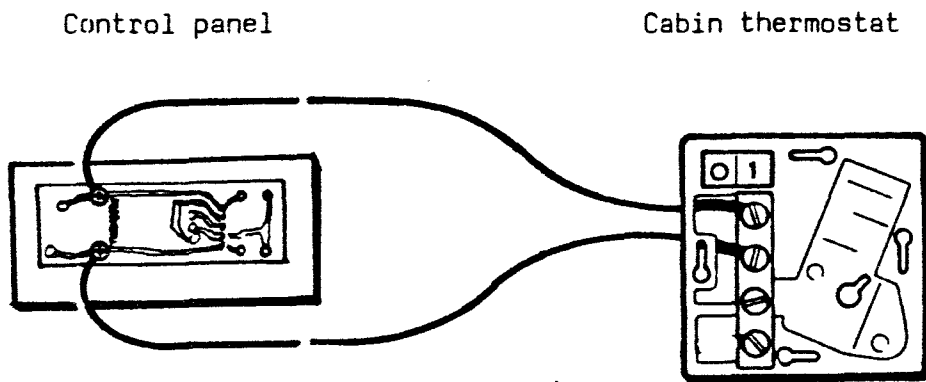

When connecting the cabin thermostat, the heater will not stop but will adjust itself between maximum and set value on the control panel.

COMPONENTS

Burner unit

The burner unit consists of the following components: Burner casing (1), flame holder (2), four frames (3) and four rings (4). On the bottom of the burner casing a glass fibre mat (5) is mounted.

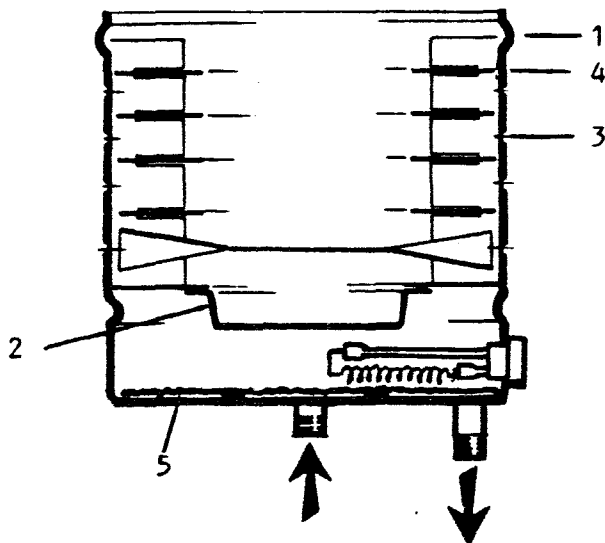

### Fuel pump

The fuel pump is a membrane dosage pump. An electrical motor operates the fuel pump. The fuel flow to the heater can be adjusted by a potentiometer on the printed circuit card. See REPAIR INSTRUCTIONS.

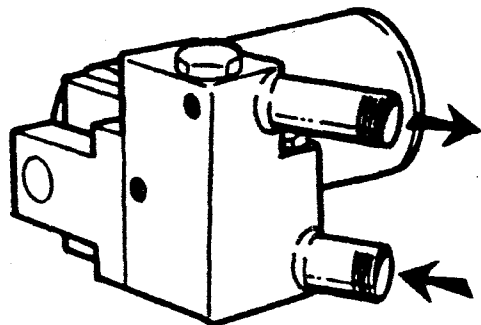

### Printed circuit card

Turning potentiometer

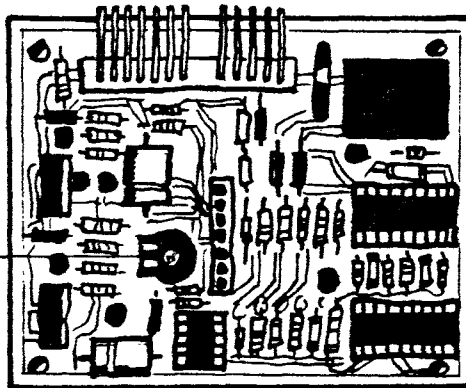

The printed circuit card controls the heater functions. The following circuits are integrated in the card:

#### Two-minutes circuit

Pre-heating time, during which the glow unit is engaged.

#### 17-minutes circuit

If the re-cooling thermostat does not close within this time (yellow lamps goes on), the heater will stop automatically.

On the printed circuit card there is also a turning potentiometer to

### Fuel pump

The fuel pump is a membrane dosage pump. An electrical motor operates the fuel pump. The fuel flow to the heater can be adjusted by a potentiometer on the printed circuit card. See REPAIR INSTRUCTIONS.

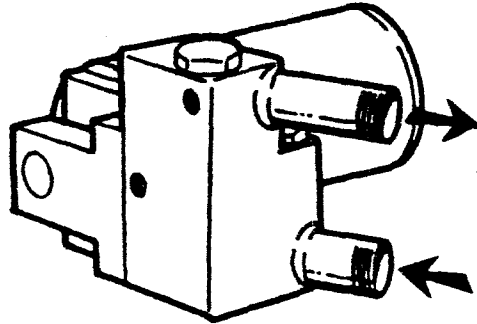

### Printed circuit card

Turning potentiometer

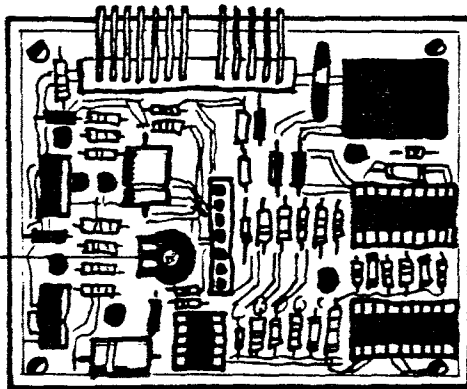

The printed circuit card controls the heater functions. The following circuits are integrated in the card:

#### Two-minutes circuit

Pre-heating time, during which the glow unit is engaged.

#### 17-minutes circuit

If the re-cooling thermostat does not close within this time (yellow lamps goes on), the heater will stop automatically.

On the printed circuit card there is also a turning potentiometer to adjust the fuel flow and pins for connection of the control panel cables.

### Overheating thermostat

The heater is equipped with an overheating thermostat. It is situated in the warm air outlet. The thermostat is reset by pushing the centre button after cooling.

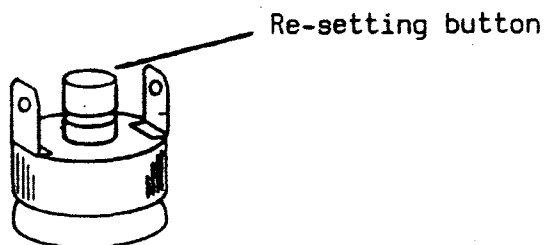

### Re-cooling thermostat

The thermostat controls the connection of the fans to obtain re-cooling after switching off the heater.

The yellow indicator lamp on the control panel goes on when the thermostat closes.

The thermostat stops the fans when the temperature in the burner unit has gone down sufficiently.

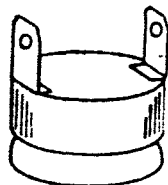

ELECTRICAL CONNECTIONS

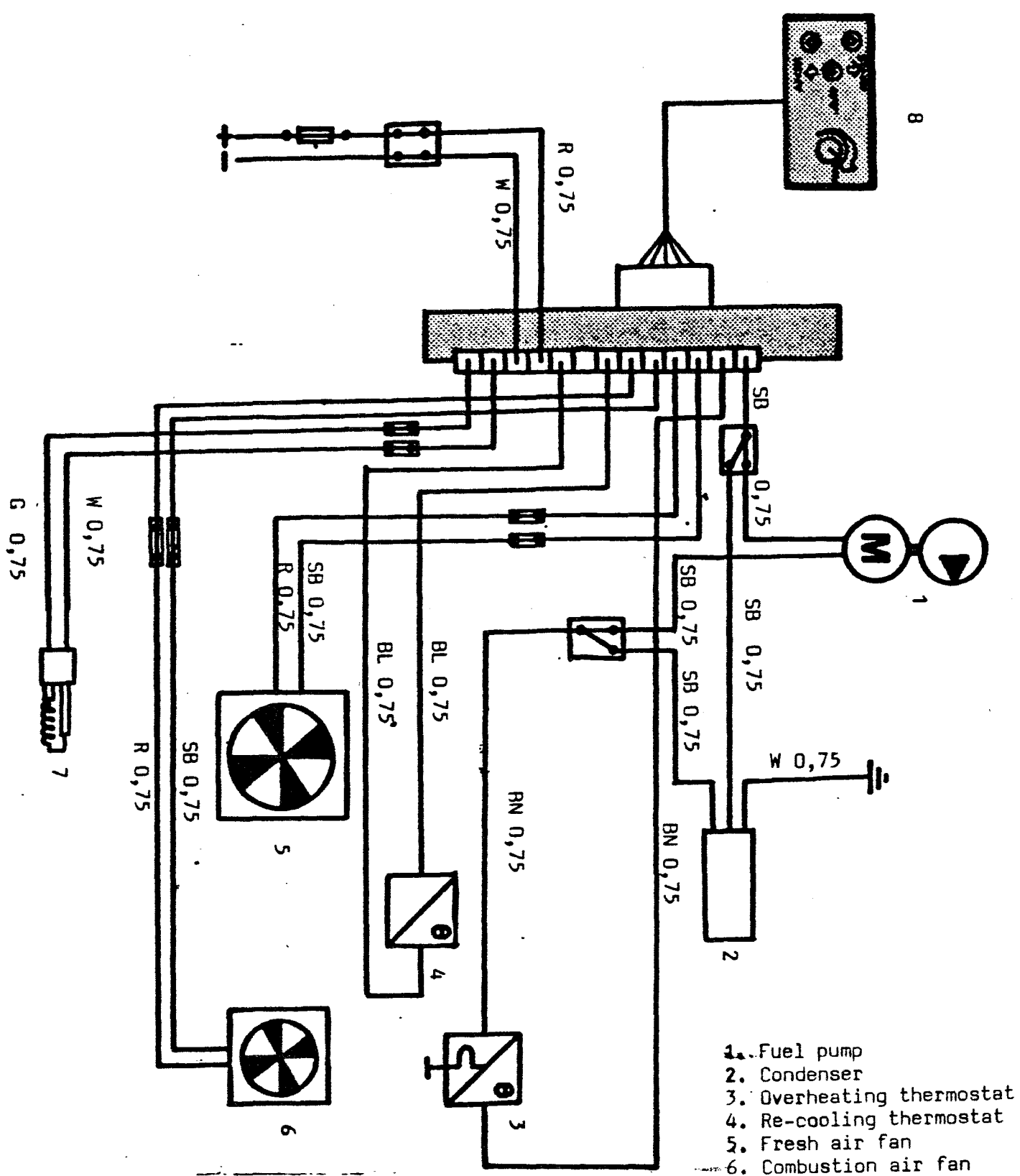

- 1. Fuel pump
- 2. Condenser
- 3. Overheating thermostat
- 4. Re-cooling thermostat
- 5. Fresh air fan
- 6. Combustion air fan
- 7. Glow unit
- 8. Control panel

R = Red  
 W = White  
 SB = Black  
 BL = Blue  
 GR = Grey  
 BN = Brown

## FAULT TRACING

### Fault types

1. Heater does not start (no current).
2. Heater starts, but does not ignite (breaks on the safety circuit).
3. Heater starts and ignites but breaks on the safety circuit.
4. Heater starts and ignites but goes out after a while.
5. Heater smokes and/or soots.
6. Fans do not stop.

### Fault tracing table

The fault tracing table on the next page covers fault tracing and action to correct the types of faults described.

### Service tools

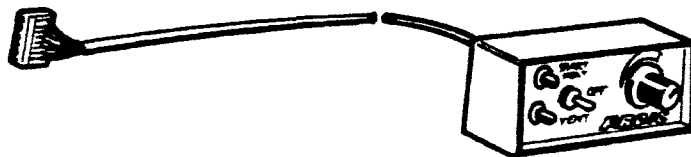

## FAULT TRACING TABLE

Type of fault	Indication	Check/remedy
1. Heater does not start (no current)	Blown fuse	Look for short circuit Replace fuse
	Cable fault (interruption or oxidation)	Check cables, battery, control panel-printed circuit card-earth
	Defective control panel	Check control panel Replace control panel
2. Heater starts but does not ignite (breaks on safety circuit)	Defective glow unit	Check glow unit visually Replace glow unit
	No fuel feed	Check fuel pump Remedy possible blocking in fuel pipe Check that there is voltage from pump to printed circuit card
	Overheating thermostat in warm air output released	Check that there is no blockage in hoses Lower the voltage to the fuel pump on the printed circuit card Check fan motor Replace fan motor Check overheating thermostat Replace thermostat
3. Heater starts and ignites but breaks on safety circuit	No combustion air	Check combustion fan
	Too low fuel flow	Check exhaust temperature Adjust voltage to fuel pump on printed circuit card.
	Re-cooling thermostat does not break	Check thermostat Replace thermostat

Type of fault	Indication	Check/Remedy
4. Heater starts and ignites but shuts down after a while	Overheating thermostat in warm air outlet releases	See fault type 2
5. Heater smokes and/or soots	Wrong fuel flow  Defective combustion fan motor	See fault type 3 Check rubber connections  Check fan rotation speed about 13 000 r/m Replace fan motor
6. Fans do not stop	Re-cooling thermostat does not break	Yellow lamp does not go out Replace re-cooling thermostat

The printed circuit card is not found in this fault tracing table. If fault still remain despite of the above checks/remedies, try replacing printed circuit card.

## REPAIR INSTRUCTIONS

### Setting of fuel flow

Set the fuel flow when test running the heater.

1. Connect a 200 mm long air hose on the outlet.
2. Start the heater and when the yellow lamps goes on, turn the temperature control to maximum. Measure the the exhaust temperature after approx. 5-10 minutes. The temperature increase  $\Delta t$  shall be  $75-80^{\circ}$  C.

$$(\Delta t = \text{temp}_{\text{out}} - \text{temp}_{\text{in}})$$

### Adjustment of fuel flow

1. Loosen the rubber bushing (A).
2. Turn the potentiometer (B) so the correct temperature increase is obtained (to the left - lower temperatur, to the right - higher temperature).

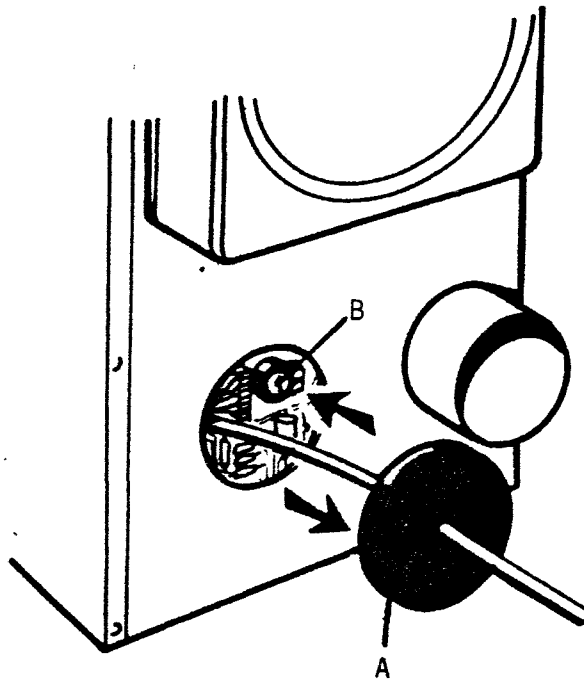

### Replacement of overheating thermostat (C)

1. Fold the thermostat bracket outwards, see drawing.
2. Loosen the electrical cables and replace part.
3. Mount new part in reverse order.

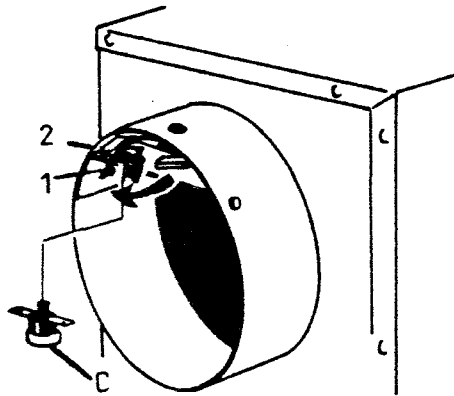

### Replacement of fan motor (D)

1. Loosen the electrical cables on the fan motor.
2. Loosen the 4 screws holding the fan motor in position.
3. When mounting new fan motor, don't forget to install the protective grating.

N.N. Connect red cable to + on the fan.  
Connect black cable to - on the fan.

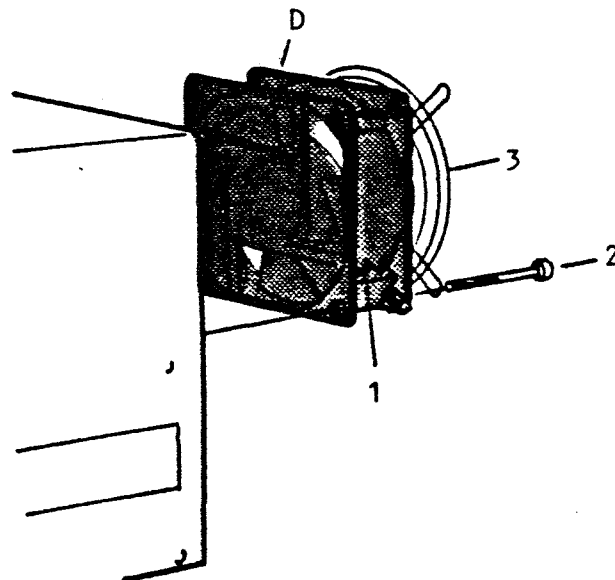

When carrying out the following repairs, the heater shall be removed from the boat and the base plate dismantled (6 screws).

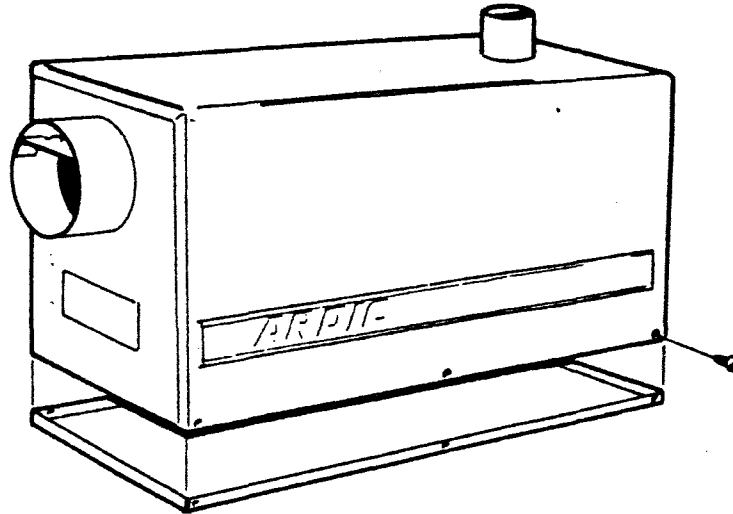

#### Replacement of fuel pump (E)

1. Loosen the electrical cables on the fuel pump.
2. Loosen the fuel hoses.
3. Cut the clamp holding the condenser.
4. Loosen two screws holding the bracket in the heater.
5. Loosen the bracket from the fuel pump.
6. Mount new fuel pump i reverse order.

N.B. Clamp the condenser and connect the brown cable to + on the pump and black to - on the pump. If connected incorrectly, the electrical motor will rotate in the wrong direction and can be damaged.

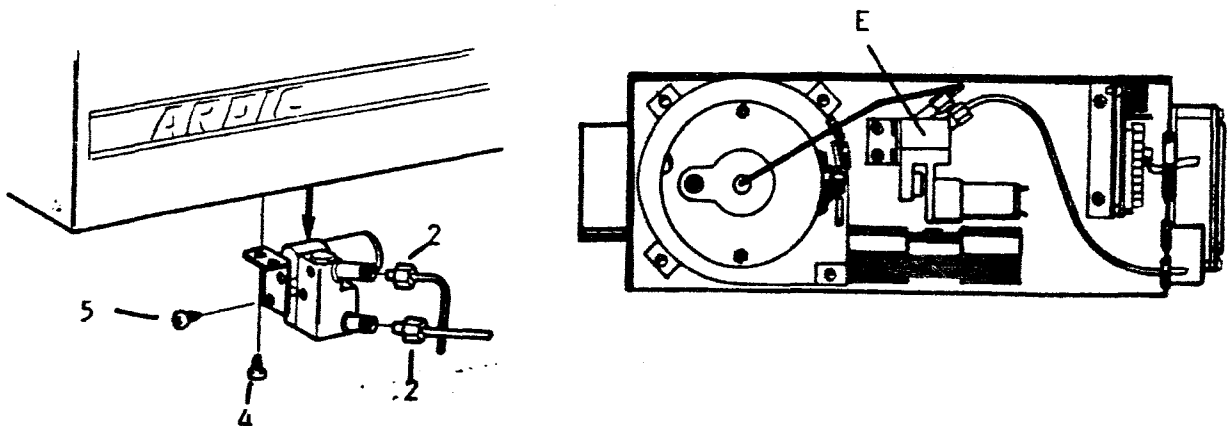

### Replacement of combustion fan (F)

1. Loosen the electrical cables at the joint sleeves.
2. Loosen the fan from the rubber hoses.
3. Install new combustion fan in reverse order.

N.B. Ensure that the arrow on the fan is turned in the correct direction. Be careful and don't press the fan wheel!

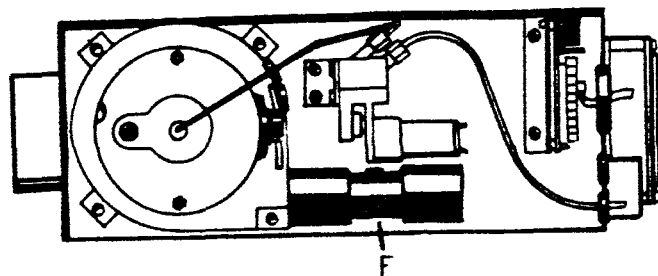
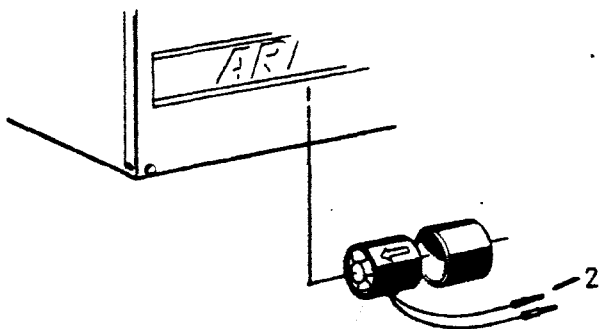

### Replacement of printed circuit card (G)

1. Loosen the contact piece from the printed circuit card.
2. Loosen two screws.
3. Lift up printed circuit card with bracket.
4. Loosen the printed circuit card from the bracket.
5. Mount new printed circuit card in reverse order.

N.B. Connect the cable to the condenser.

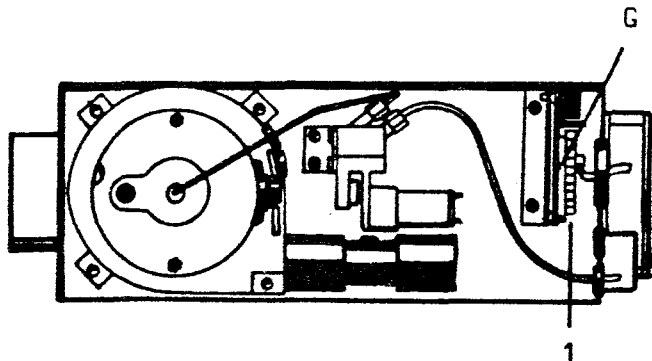
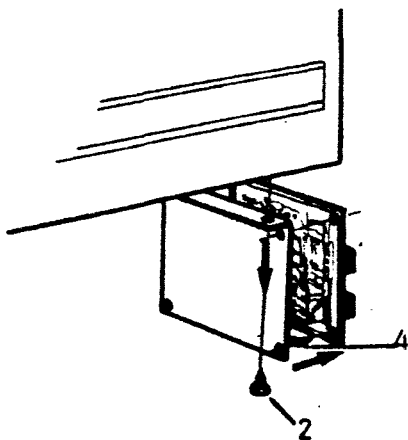

### Replacement of return nipple (H)

1. Remove the rubber washer.
2. Loosen four screws.
3. Remove the burner bottom.
4. Loosen the return nipple.
5. Mount new return nipple in reverse order.

N.B. Tighten the return nipple by hand, use no tool. The return nipple and the return pipe must not be screwed on during operation.

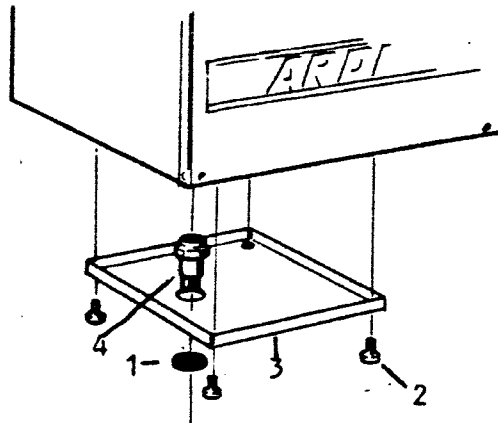

### Replacement of glow unit (I)

1. Disconnect return nipple as described above.
2. Loosen the coupling nut on the burner unit.
3. Disconnect the electrical connection for the glow unit.
4. Loosen the nuts for the burner unit fitting.
5. Remove the bottom plate.
6. Lift up the burner unit.
7. Loosen the screw and remove the bracket.
8. Take out the glow unit.
9. Mount the glow unit in reverse order.

N.B. Be careful when mounting a new glow unit.

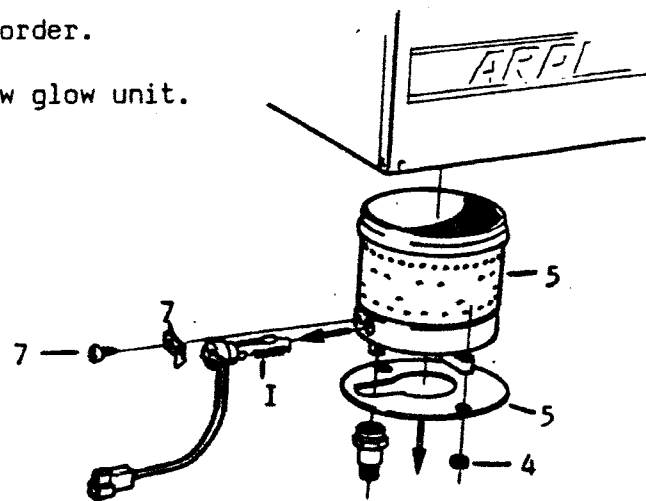
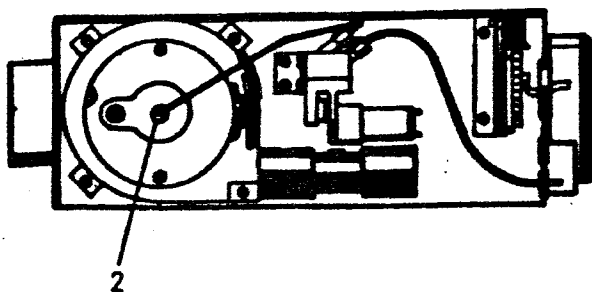

### Replacement or cleaning of burner parts

1. Disconnect burner unit as described above.
2. Remove the locking for the rings.
3. Lift up the rings and flame holder. Clean and replace parts if necessary.
4. Mount in reverse order.

N.B. Check with a thread that the flame holder does not cover the row of holes, see drawing.

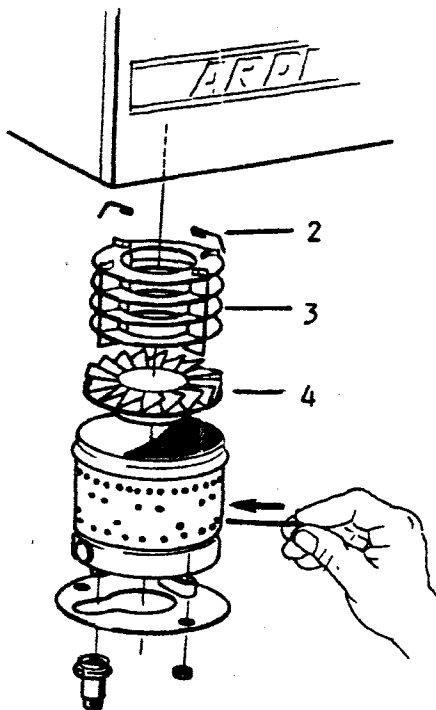

### Replacement of glass fibre wick

1. Disconnect the burner unit as described above.
2. Remove the glass fibre wick from the burner casing bottom.
3. Replace glass fibre wick and mount in reverse order.

### Replacement of re-cooling thermostat (K)

1. Loosen the burner bottom as described earlier.
2. Loosen the electrical connection to the glow unit.
3. Loosen the coupling nut.
4. Disconnect electrical connections to re-cooling thermostat.
5. Loosen four screws and lift up the burner bottom.
6. Loosen two screws holding the bracket and thermostat.
7. Replace thermostat and mount in reverse order.

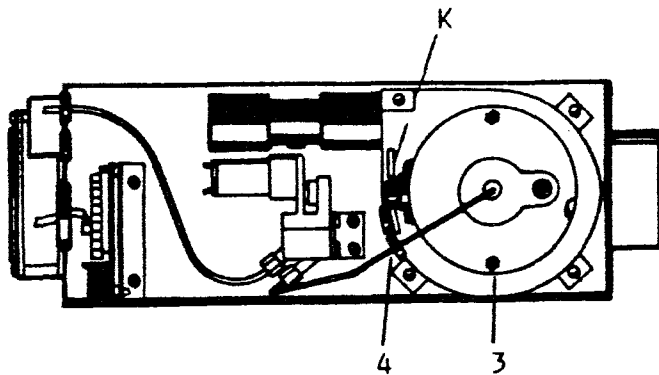
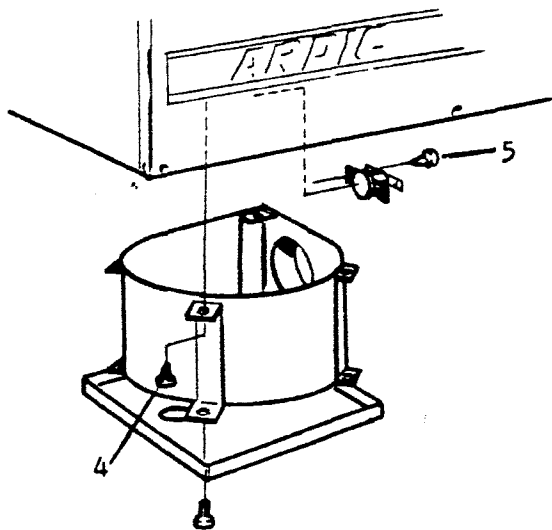

## PERIODIC OVERHAUL

### Prior to warranty work

Heaters which have been installed for a period of four months or longer must undergo a routine service before any warranty work is carried out.

This also applies to heaters in commercial use etc, which have been in operation for a period of 400 operating hours or more.

## GENERAL SERVICE

The routine service should be carried out after 400 hours of operation, or at least once a year.

### The service includes

Removal of burner unit, cleaning and checking.

Check

- that all components are securely attached,
- that the air hoses are not blocked,
- that the combustion air intake is not blocked,
- that the exhaust pipe is not damaged and routed so that no flammable components are touching or in close proximity of the hot parts of the exhaust system,
- that the fuel hoses are not damaged and that the hose clamps are not loose,
- that the cables are properly connected and the fuse intact,
- that the electrical connections are not corroded,
- that there are no voltage drops and that the battery condition is good.

After servicing - start the heater and check it's function and measure outgoing air temperature.

## DRAWING

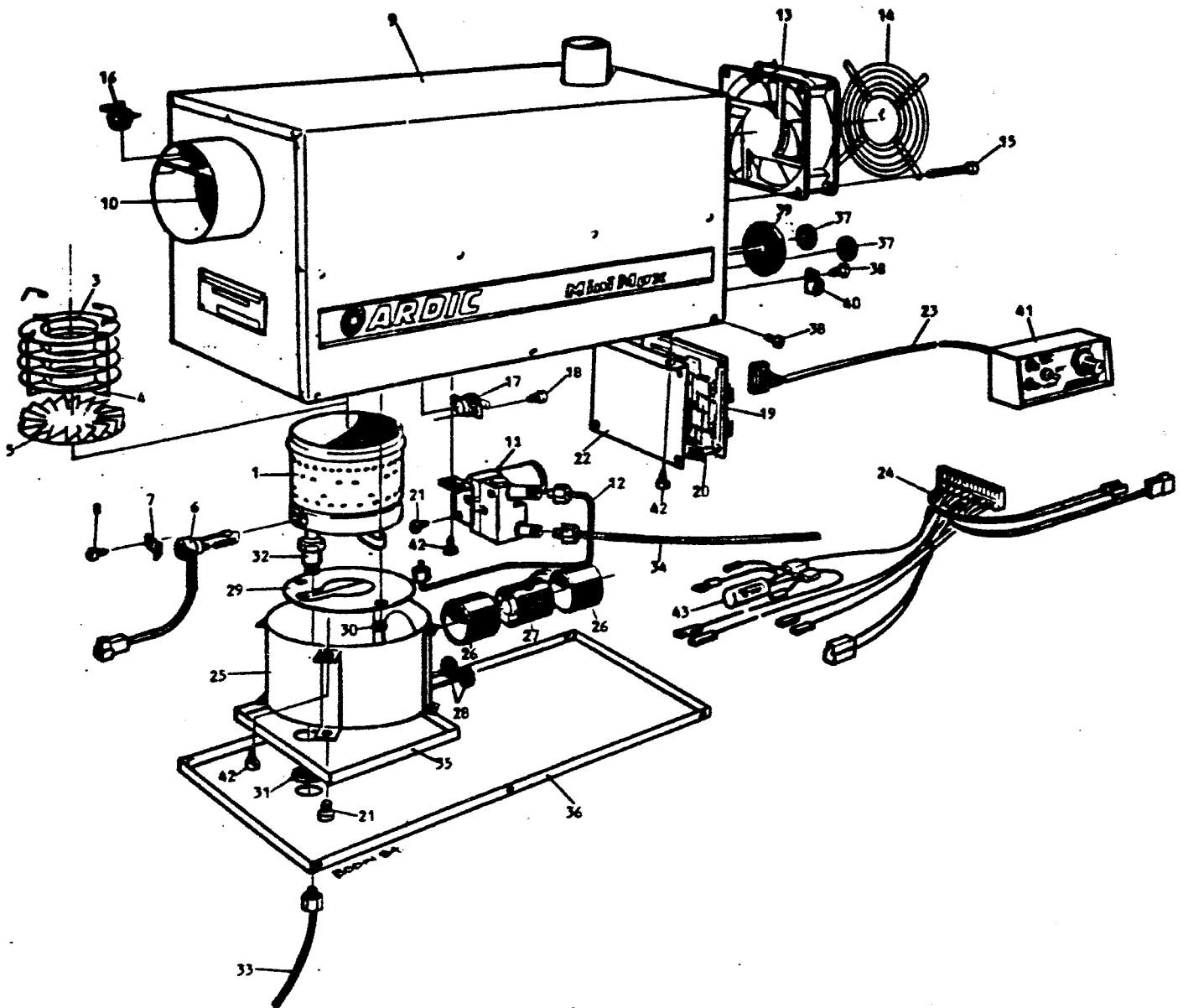

1	3713514	Burner incl wick	23	3713624	Outer cabling
2	3713104	Wick	24	3713572	Inner cabling
3	3713523	Ring	25	3713562	Burner mantle
4	3713524	Frame	26	3713177	Rubber hose
5	3713526	Flame holder	27	3713178	Combustion fan
6	3713531	Glow unit	28	941262	Protective bushing
7	3713581	Brace	29	3713566	Bottom plate
8	965232	Screw	30	944456	Nut
9	3713533	Heater casing	31	469478	Rubber sealing
10	3713534	Heat exchanger	32	8047228	Return nipple
11	3713571	Fuel pump	33	8047124	Return pipe compl
12	3713552	Fuel pipe	34	8047123	Fuel pipe comp
13	3713154	Fresh air fan	35	3713567	Burner bottom
14	3713367	Fan grating	36	3713569	Heater bottom
15	956071	Screw	37	941267	Protective bushing
16	3713558	Overheating thermotat	38	955125	Screw
17	3713148	Re-cooling thermostat	39	943920	Protective bushing
18	955119	Screw	40	3713417	Clamp
19	3713559	Electronics	41	3713379	Control panel
20	3713653	Holder	42	955129	Screw
21	955127	Screw	43	3713422	Condenser
22	3713561	Bracket			