

Hints and advice

on rigging and tuning of your Seldén mast



Instructions for rigging. Conditions for valid guarantee.



Introduction	2
Rig types	4
Longitudinal rigging	6
Lateral rigging	8
Running rigging	10
Preparing the yacht for rigging	13
Checking the mast	14
At the crane	20
Keel-stepped masts	22
Alternative rigging of jib furling system	26
Tensioning the cap shrouds	28
“The folding rule method”	29
Tuning for safety	30
Masthead rigs	32
Fractional rigs	42
19/20 rig and similar	48
Bergström-Ridder rig	50
Booms	53
Rodkicker	56
Working aloft	57
Unstepping the mast	60
Winter maintenance	61
Damage or cosmetic flaws?	65
Storage	66
Mounting new fittings	67
Masts which are seldom unstepped	68
Boat ashore with the rig still in place	68
Calculating mast and rig dimensions	69
Positive roach + in-mast furling	72
Sail slides and sail entry (MDS)	73
The Seldén product range	74
Notes	80
Conversion factors	81

The rig

The rig – a combination of masts, booms, rigging and all types of equipment. It is obvious that the rig is a large and vital part of your yacht. Tuning for the best mix of performance, reliability and operating safely requires a degree of knowledge. With “Hints and advice”, we aim to share with you our practical experience. You probably know most of this, but there is always something new to learn.

The first part of the book describes stepping masts and preparations in general. It is **absolutely essential** that you read this information, no matter what type of rig you have.

After you have done that, please follow the rigging instruction appropriate to your rig type. **This is, of course, important from a safety point of view, but it is also a condition of our guarantee.**

We will also give you an insight into how our rigs should be handled in practice, and the best way for you to look after your rig to ensure that it performs well for many years.

When you read “Hints and advice”, you might come across some unfamiliar technical terms. Nautical language is famous for using words which are unfamiliar to many people. We suggest you have our product catalogue to hand alongside “Hints and advice”, as it has an alphabetical index and illustrations of most of the components of a rig.

We hope you’ll find “Hints and advice” useful.

Fair winds,
The Seldén Group



Bear in mind that, as the yacht's Owner, you are responsible for any accidents or damage resulting from negligence or poor handling. Seldén's "Hints and advice" is an educational aid, but ultimately, the safety of vessel and crew depend on the care and judgement exercised by the yacht's skipper.

Rig types

Masthead rig

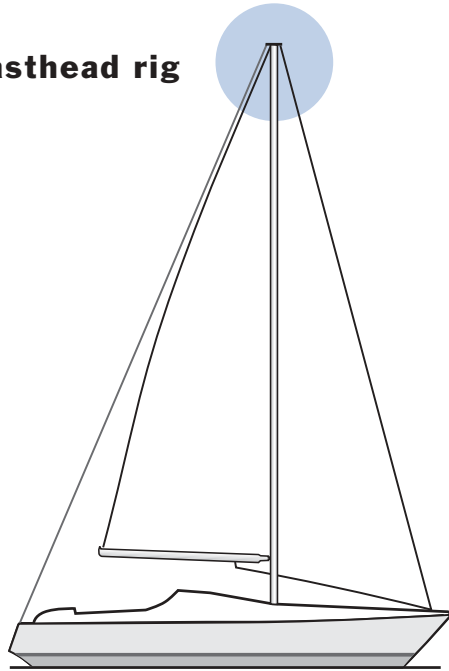

Fractional rig

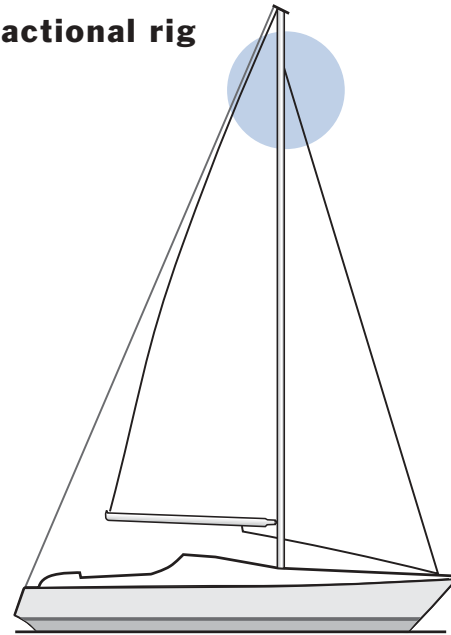

Deck-stepped mast

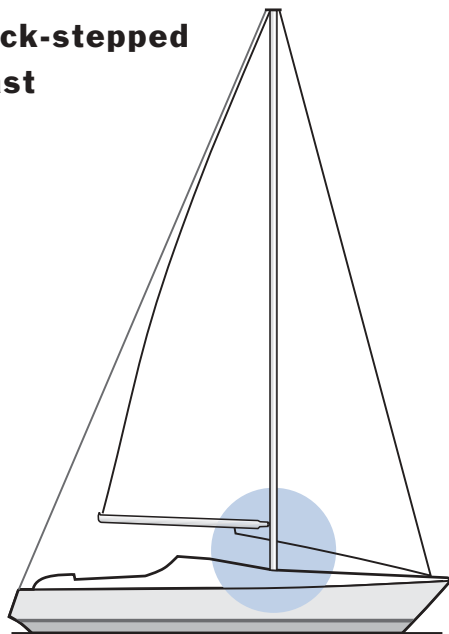

Keel-stepped mast

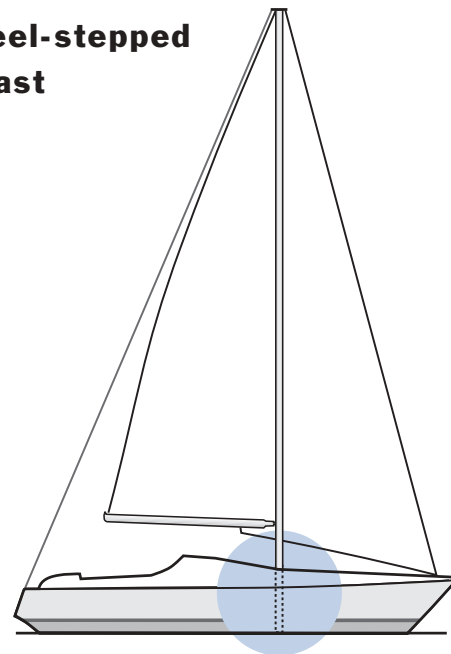

Single or multiple-spreader rigs

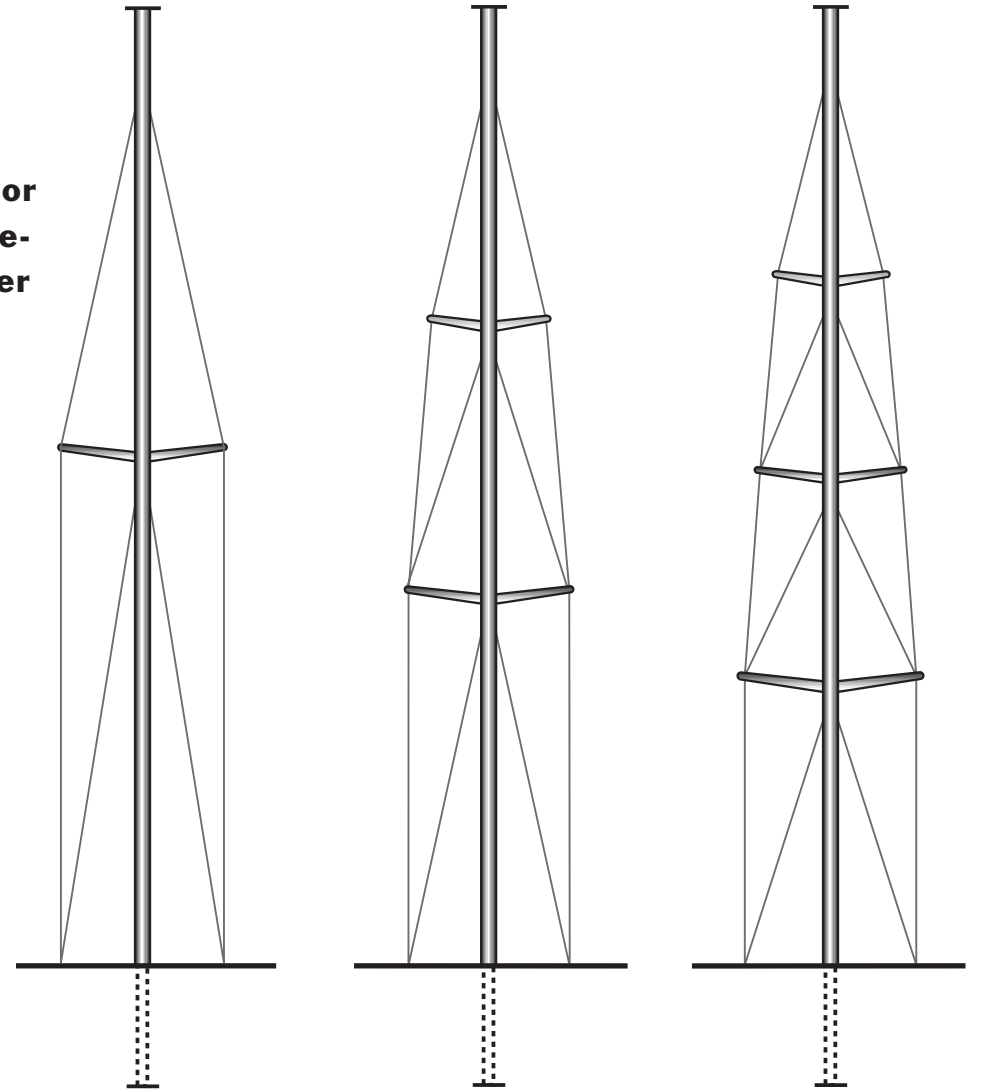

In-line spreaders

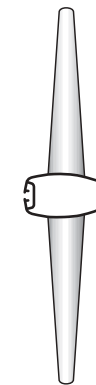

Swept spreaders

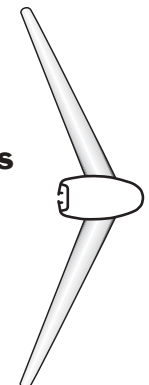

Longitudinal rigging

Backstay: Stays the top of the mast against movement forwards. The backstay tension is adjusted using some form of tensioning device to control mast-bend and forestay tension.

Forestay: Sail-carrying stay for the genoa and jib. Prevents the top of the mast moving aft. The tension of the forestay is affected by the backstay, cap shrouds (on rigs with swept spreaders), runners and the sheeting of the mainsail.

Cutter stay: Sail-carrying inner stay for jib or staysail. On a masthead rig, if it can be attached within 6% of the fore-triangle height below the forestay fitting, it can be tensioned by the backstay. If it is attached lower down, runners or possibly forward-angled jumpers must be used.

Inner forestay: Attached about 60% of the fore-triangle height above the deck. This stay does not carry a sail, but is intended only to stay the mid-section of the mast fore-and-aft, in conjunction with checkstays.

Baby stay: Attached in the region of the lower spreaders. The stay is not sail-carrying, but is intended to stay the lower panel of the mast fore-and-aft, in conjunction with aft lower shrouds.

Runners: Also known as "running backstays". On a masthead rig, runners interact with a cutter stay. They are more commonly found on fractional rigs, where they are used to tension the forestay. Runners consist of two wires attached to the sides of the mast. The runners are adjusted using tackles at their lower ends. The windward runner is always under tension. The leeward runner is always slack, otherwise it would interfere with the mainsail and boom. Runners fitted close to the yacht's midships line only affect the fore-and-aft staying of a mast with in-line spreaders. If they are fitted to the yacht's quarters they also affect the lateral rigging.

Checkstays: Function in principle as runners, but are attached lower down the mast. They are intended to stabilise the mid-section of the mast to prevent uncontrolled mast-bend and pumping. Checkstays normally interact with the inner forestay.

Triatic stay: Forestay for a mizzen mast. Attached between the masthead fittings. On smaller yachts, the stay is led through a block at the mizzen mast top down to the deck, where the length can be adjusted.

Masthead rig

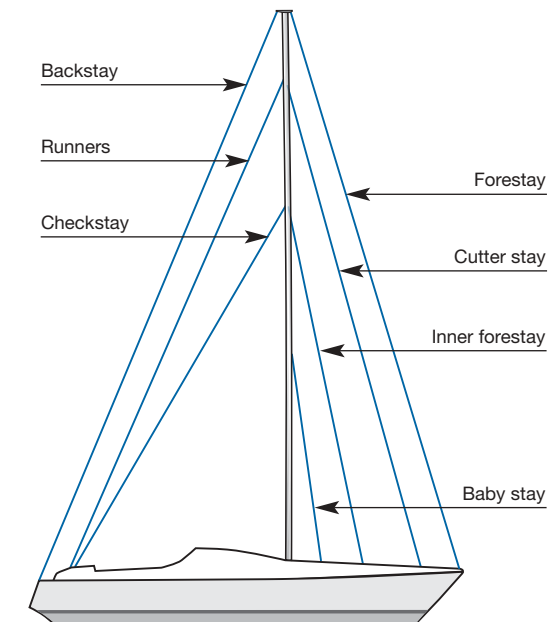

Fractional rig

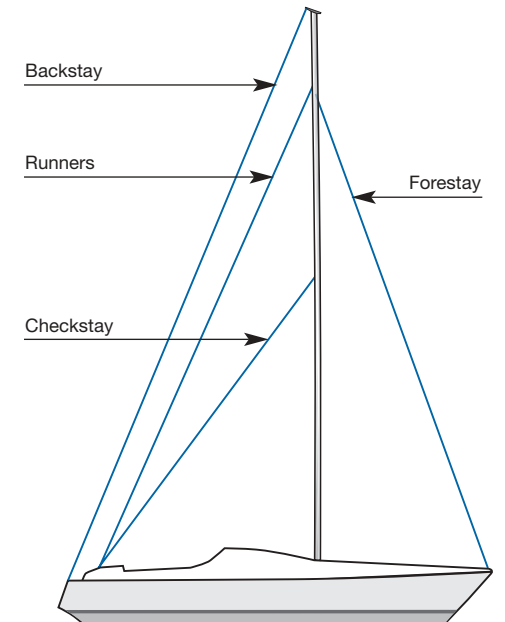

Lateral rigging

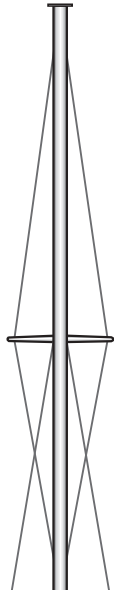

Jumper arrangement
 This type of arrangement is designed for fractionally rigged yachts. The jumper struts are normally angled forward. The jumper arrangement stays the top mast, not only athwartships but also fore-and-aft. The use of jumper struts enables the top mast to be given a more slender taper. A jumper arrangement might be necessary when using a masthead gennaker/spinnaker or for stabilising the top of the mainsail.

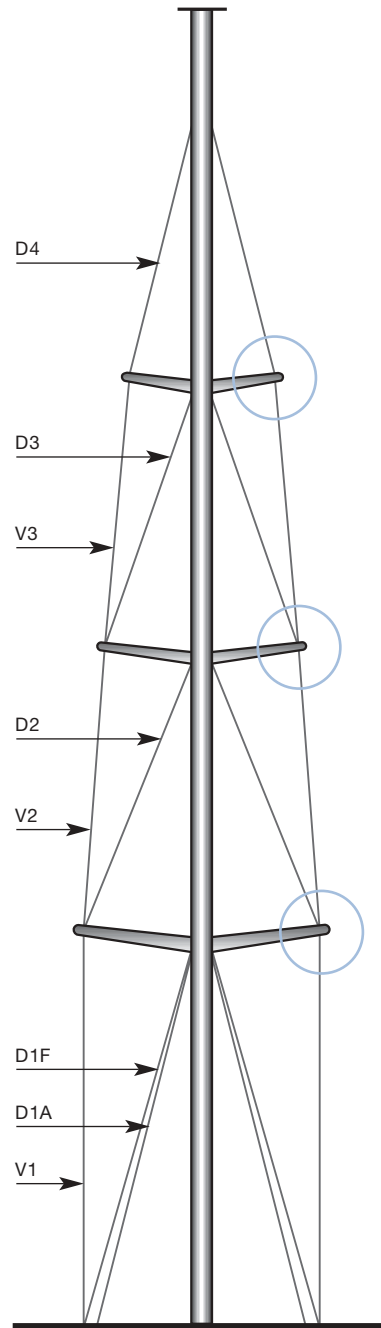

D = Diagonals V = Verticals

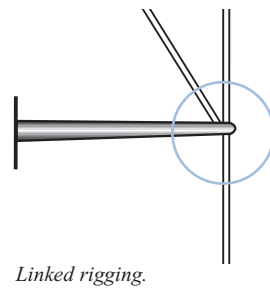

Linked rigging.

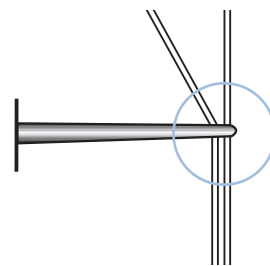

Continuous rigging.

Cap shrouds: (V1-V3, D4) Stay the mast against lateral (athwartship) loads. Attached near the masthead on a masthead rig, and at forestay level on a fractional rig. The cap shrouds are led via spreaders to the boat's chain plates.

Jumper stay ("jumper"): Permanent arrangement for staying a long mast top on a fractionally rigged mast.

Intermediate shrouds: (D2-D3) Fitted on multiple-spreader rigs, and attached in the area of the upper spreaders. Fitted with links in the lower spreader tips (linked rig) or pass over the spreader tips and continue down to the deck (continuous rig). The intermediate shrouds stay the upper spreader area against movement athwartships.

Lower shrouds: Attached in the area of the lower spreaders. Stay the spreader-area athwartships. Often fitted as forward lowers (D1F) and aft lowers (D1A), which also stabilise the mast fore-and-aft, as well as determining mast-bend.

Running rigging

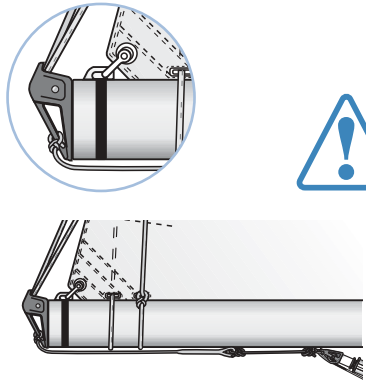

To facilitate the use of a preventer guy, a rope strop can be fitted permanently between the end fitting of the boom and the kicker slider. Tie the strop to the end fitting. The forward end has a spliced eye and a "guardrail" type lashing. When not in use, the lashing is tensioned to take up the slack.

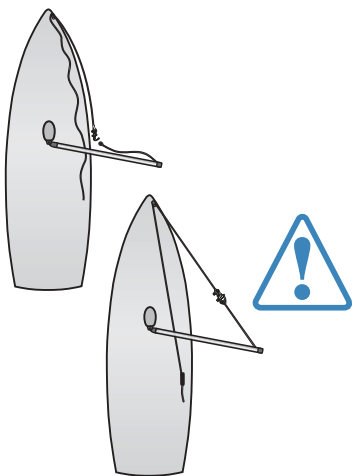

When connected, tension the bow line. Secure it to a bow cleat, or a cockpit cleat via a turning block.



Halyards: Rope or a combination of rope/wire for hoisting sails. Seldén normally colour-codes the halyards as follows:

- Genoa halyard: Blue
- Main halyard: White
- Spinnaker halyard: Red

Prevent over-tensioning of the genoa halyard

The forestay must be properly tensioned each time the sail is hoisted. You should therefore tension the backstay and any running backstays **before** tensioning the luff. If the sail is hoisted firmly before the forestay is tensioned, this may put excess strain on the halyard, halyard swivel (if a jib furling system is used) and sail.

Mainsheet: Tackle for sheeting the mainsail. Attached to the end of the boom (end-sheeting) or further forward on the boom (centre-sheeting). The lower part of the mainsheet is usually fitted to a car which runs on the mainsheet track. The car's position on the track depends on how you want to trim the sail.

Genoa/jib sheet: Line for sheeting the foresail. Led via fairleads/deck blocks to sheet winches. The location of the deck blocks can usually be altered fore-and-aft, depending on how you want to trim the sail.

Preventer guy: Used to prevent accidental gybes. Attached to the outer end of the boom, and led forward to a cleat or led via a snatch block on the foredeck, then aft to the cockpit. The preventer guy must not be fitted to the centre of the boom since that could cause damage, especially if the end of the boom goes into the water as a result of rolling.

Outhaul: Used to adjust the foot of the mainsail.

Reefing lines: Used to reef the mainsail. In Seldén's Single-Line booms, both the leach and the luff are reefed by pulling one line. Seldén colour-codes the reefing lines as follows:

- Reef 1: Blue line.
- Reef 2: Red line.

Cunningham: Line for tensioning the luff of the mainsail.

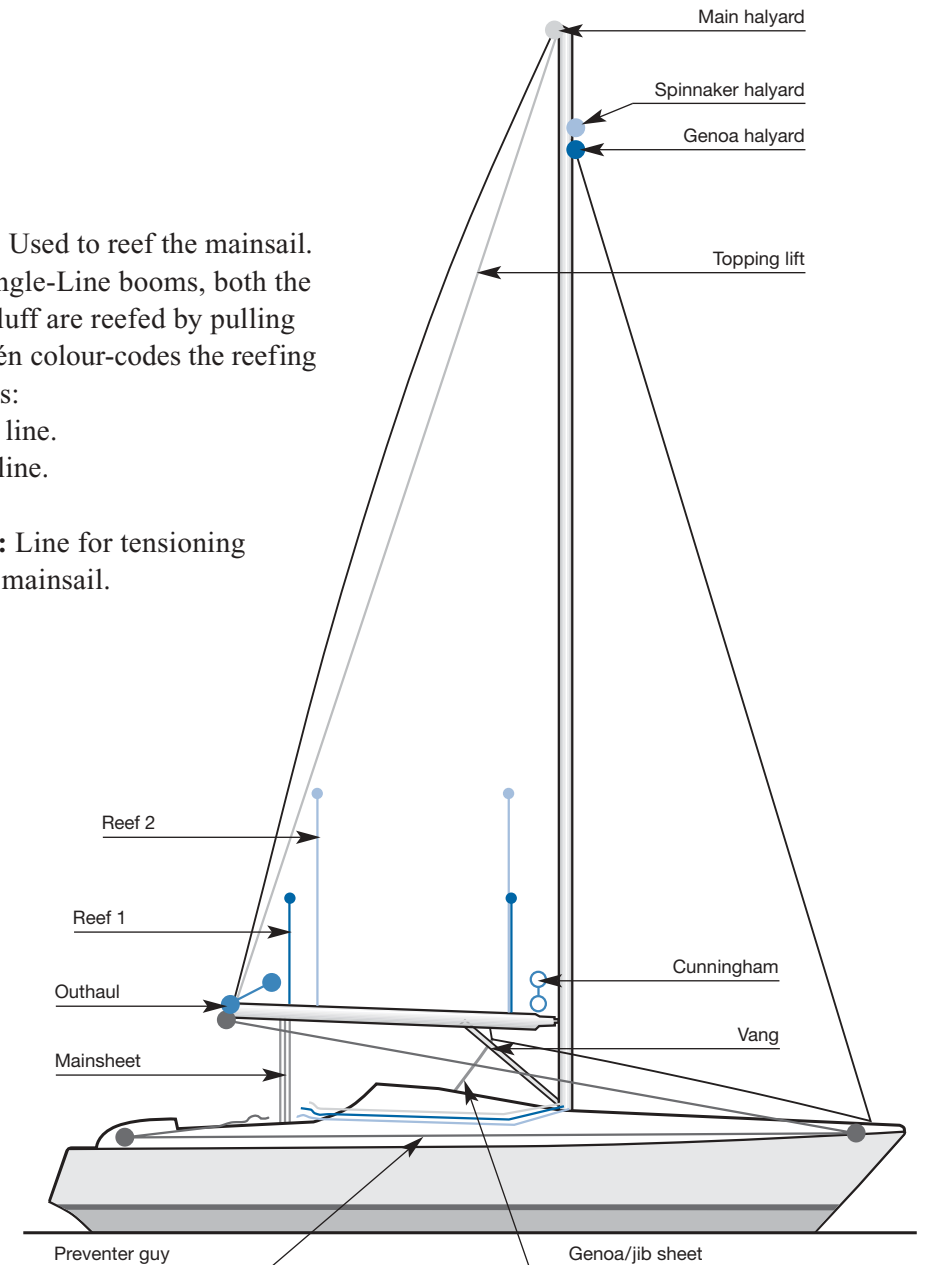

Topping lift: Used to prevent the boom end dropping into the cockpit when not supported by the sail, for example while reefing.

Vang (Kicking strap): Prevents the boom end from "lifting" when sailing downwind. Flattens the sail, and reduces twist. Often combined with Seldén Rodkicker, which takes over the function of the topping lift.

Continued...

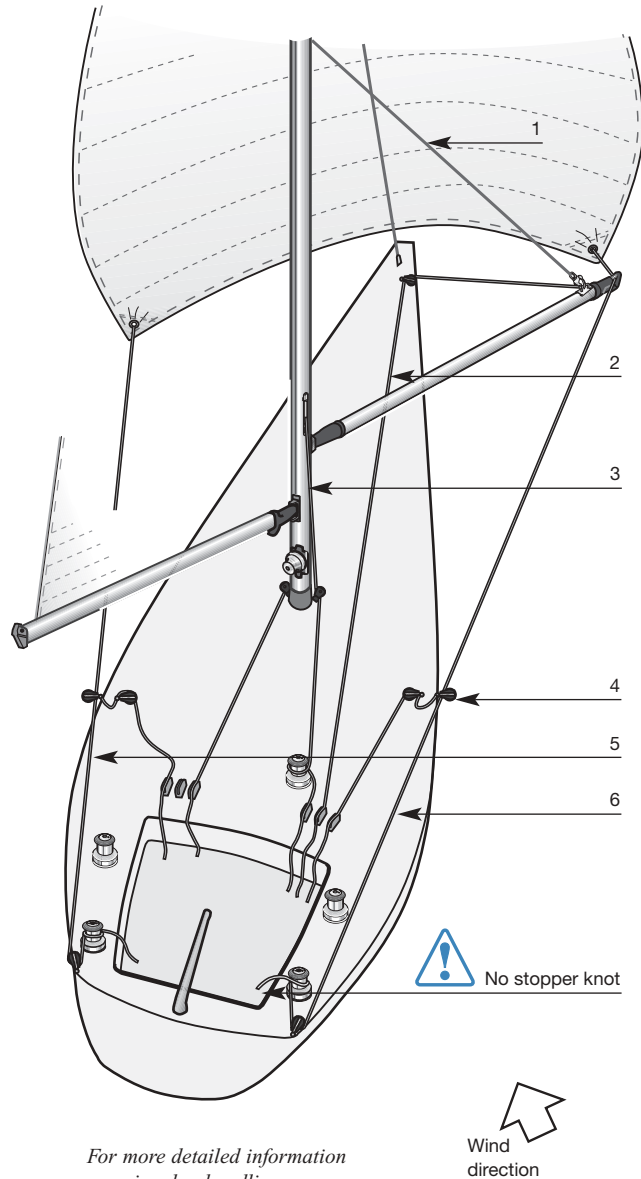

For more detailed information on spinnaker handling, see our booklet "Using a spinnaker", Art. No. 595-560-E.

Wind direction

Lift: Used to lift the spinnaker boom or support its weight. Attached to the spinnaker pole and led via a block on the mast to the deck. (1)

Downhaul: Used to set the horizontal position of the spinnaker pole in conjunction with the lift. Sometimes attached via a bridle. (2)

Pole heel lift: Line for adjusting the height of the spinnaker traveller on its track for trimming purposes. Also used for a vertical spinnaker pole stowage (VPS). (3)

Barber hauler: Line fitted to a block which runs amidships on the spinnaker sheet. Used in heavy weather to reduce the risk of the spinnaker oscillating. (4)

Spinnaker sheet: Line for sheeting the spinnaker clew (on the leeward side). Led to winches via snatchblocks on the quarters. Required length is 2 x boat length. (5)

Spinnaker guy: Windward spinnaker sheet. (6)

Preparing the yacht for rigging

The following points should be taken care of before moving the yacht to the crane

- Take out all the tools you will need during rigging.
- Make sure all rigging screws are cleaned and lubricated with rigging screw oil.
- Rigging screws with the upper thread swaged onto the wire (stud rigging screws) are threaded for extension by twisting the body clockwise. Fit this type of rigging screws to the standing rigging.
- Fit all other rigging screws to the yacht's chain plates with the left-hand thread downwards. Extend the rigging screws to the maximum extension by twisting the body clockwise. Ensure that the clevis pin at the upper end of the rigging screw can be removed quickly. All rigging screws will now operate in the same direction, and it will be easier to attach the shrouds and stays.
- Fit backstay adjuster.

The fork-ended rigging screw shown right may only be used if the chainplate is angled correctly and the rigging screw able to align with the stay. If not, a toggle must be inserted or a rigging screw with a toggled fork used.

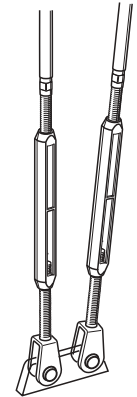

Stud rigging screws.

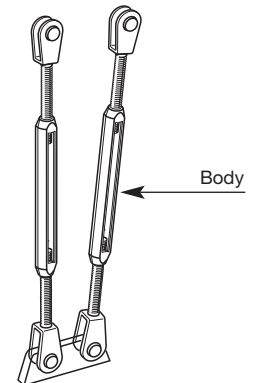

Fork/fork rigging screws.

Checking the mast and the standing and running rigging prior to stepping the mast

New mast being rigged for the first time



Halyard knot.

- **Establish the centre of gravity** of the mast by laying the mast on a trestle like a seesaw. Mark the centre of gravity with a piece of tape on the forward side of the mast. You will use this mark later when positioning the lifting strop. Normally 60% of the mast height will do.
- **Marking the halyards.** It is important to mark the halyards to indicate when the sail is fully hoisted. This prevents the splice jamming in the halyard box/head box, damaging the sheave. Jamming will not occur if the halyard shackle is fixed by a knot. All new rope halyards will get a certain permanent elongation after the initial load. Make a temporary mark with a waterproof felt-tip pen. After some time sailing, check the marking and make it permanent using whipping twine. Using this mark together with trimming tape (a self-adhesive strip with graduated markings) on the mast or in the cockpit, assists consistent halyard trimming.
- **Genoa halyard and jib halyard.** Set the halyard shackle so that the splice or knot is just clear of the masthead sheave. Attach a length of inelastic line to provide resistance. Put a load on the halyard equal to the normal extension with the foresail, and mark the halyard at a suitable place, such as the top edge of the winch plate or where it emerges from the slot fitting or forward of the stopper in the cockpit.
- **Main halyard.** Locate the main halyard shackle so that the head of the mainsail will reach the lower edge of the calibration mark. Then proceed as above.

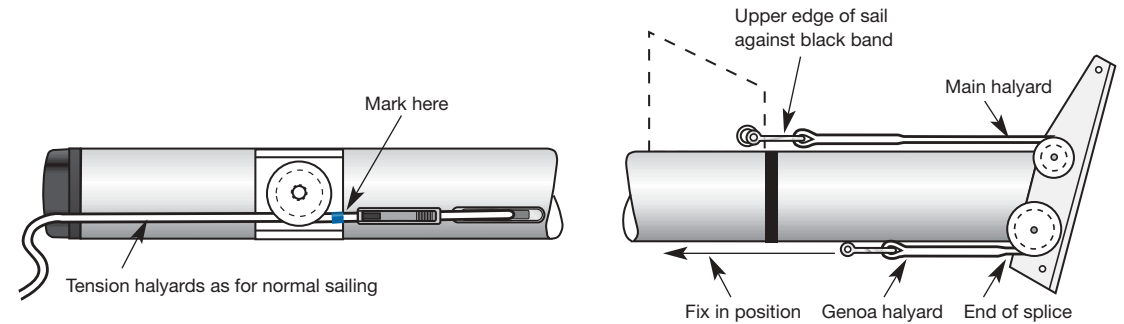

Preparing the cap shrouds and intermediate shrouds

- Attach the cap shrouds to the mast. Extend them along the mast, and check that they are the same length. If they are not, mark the difference on a piece of tape and attach the tape to one of the shrouds (e.g. "+ 7 mm"). You can compensate for the difference using the rigging screws.
- Attach the intermediate shrouds to the mast and lay these and the cap shrouds along the mast.

Continued...

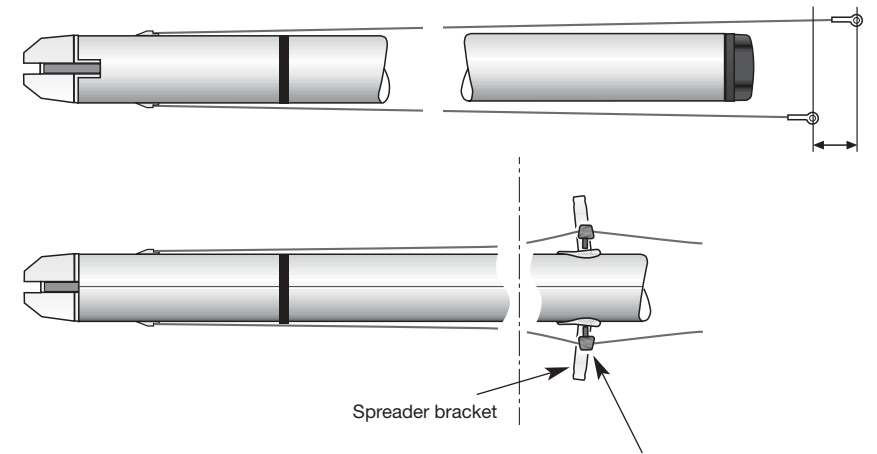

Clamping end plug to be fixed in line with spreader brackets, with shrouds tensioned along the mast. Final vertical spreader angle must always be 6°.

Continued: Checking the mast and the standing and running rigging prior to stepping the mast.

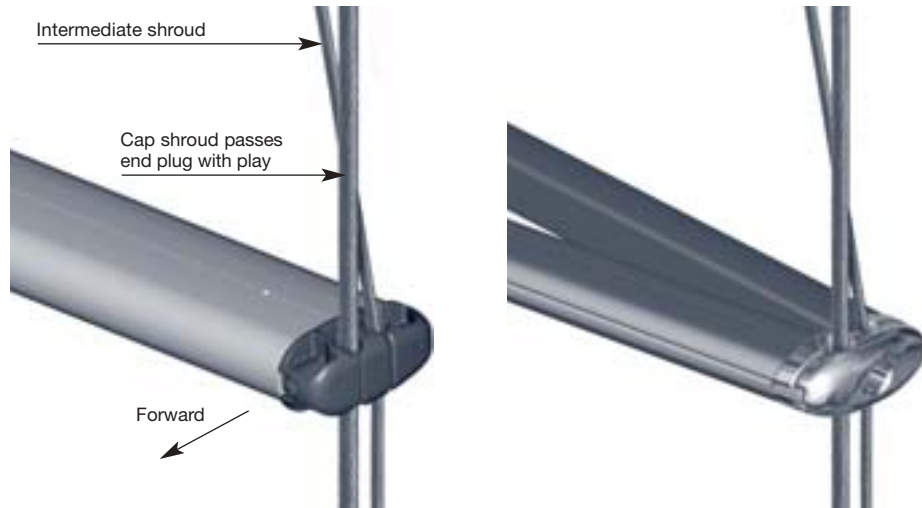

Spreader end plug for continuous rigging.

Spreader end plug for V-spreader.



Spreader end plug for linked rigging.

Spreader end cup for Rod Tip Cup.

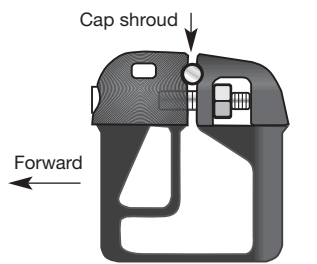

Clamping end plug for single spreader rig or top spreader on multi-spreader rig.

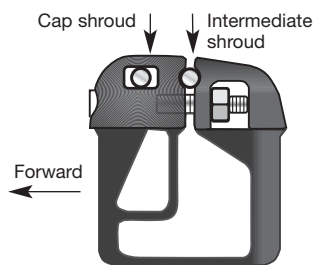

Clamping end plug for continuous rigging.

Clamping end plugs

- This is the type of spreader end used for single-spreader rigs or on multi-spreader rigs when the intermediate shroud continues on beyond the spreader tip and down towards the yacht, “continuous rigging”.
- Locate the spreader end plugs on the cap shroud and intermediate shrouds, immediately in line with the spreader brackets with the shrouds tensioned along the mast. Correct location depends on spreader length, but the final vertical spreader angle must always be 6°.
- The lower spreader end on a multi-spreader rig clamps around the intermediate shroud, whereas the cap shroud passes the end plug with some play.
- Connect the lower shrouds to the spreader brackets or to their tangs.
- Connect the spreaders to the mast.

- Fit the spreader end plugs into the spreaders. Tighten the vertical locking screw hard to fix the plug in the spreader. Tighten the horizontal locking screws hard. The spreader ends must never, under any circumstances, be allowed to slide on the shrouds. When the mast has been stepped, it must be possible to stand on the spreaders without the ends sliding.

Linked spreader ends

Fit the cap shrouds and intermediate shrouds as per illustration. Extend the intermediate rigging screw.

Rod Tip Cups

Fit the cap shrouds and intermediate shrouds as per illustration. Extend the intermediate rigging screw.

Continued...



Through-bar spreader bracket, incorporates attachments for lower shrouds or intermediate shrouds.

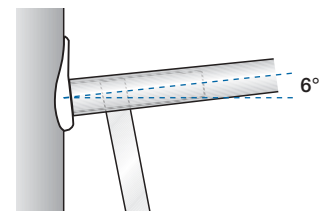

Spreader angle.

Mast, previously rigged on your yacht

- Wash the mast, boom, spinnaker pole, jib furling system and rigid vang, as well as all associated parts using a mild detergent solution. Rinse thoroughly. Treat with yacht polish or wax.
- Lubricate the sheaves with silicone spray.
- Winches should be maintained in accordance with the manufacturers' instructions.
- Lubricate the jib furling system/in-mast furling ball bearings with waterproof grease, in accordance with the separate instruction book.
- Treat any ball-bearing full batten system with silicone spray.

Electronics

- Check that the navigation lights, deck lights and wind instruments on the mast are working. A 12V or 24V battery must be available for this. This check ensures that you don't have to climb the mast after it is stepped to change bulbs or carry out repairs.
- Check all cables. If a cable has been damaged, identify the cause and rectify it.
- Lubricate all electrical connections with Vaseline to avoid corrosion.
- Never use any part of the rig for electrical ground (earthing).

Standing rigging

- Attach all shrouds and stays. The clevis pin which attaches the backstay to the masthead toggle should be fitted so that the head is towards the halyard. This prevents the halyard catching on the split pin.
- Split pins must be 1.5 x the diameter of the clevis pins in length, and the legs must be bent about 20° to them. If opened up more than this, they are difficult to remove.

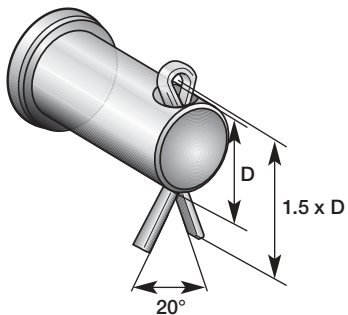

- Tape all split pins and split rings which may come into contact with running rigging and sails. Use fabric tape. Bear in mind that a spinnaker is very easily ripped if it comes into contact with anything sharp, and that in an unsuccessful attempt to lower the spinnaker, the sail can touch just about any part of the rigging.
- Lash the standing rigging temporarily to the lower end of the mast so that it does not trail around when the mast is lifted by the crane.
- If a jib furling system is to be fitted, it is laid on the forward side of the mast. Attach a line to the lower part, so that one person can control the jib furling system when the mast is being lifted by the crane. A jib furling system can also be fitted after the mast has been stepped. See pages 26-27.

Running rigging

- Check that all halyards etc. have stopper-knots (figure-of-eight) to prevent them becoming lost in the mast.
- Check that all halyards etc. run free and that none of the running rigging passes between the mast/spreaders/shrouds.
- Polish and lubricate the shackles. Consider attaching a short release cord (without loop) to quick-release shackles to make them easier to open.

Other equipment

- Fit Windex, wind instruments, aerials etc. at the mast-head if the mast can be stepped without damaging them. Alternatively, fit this vulnerable equipment afterwards.
- Reeve the flag halyards to lower spreaders.

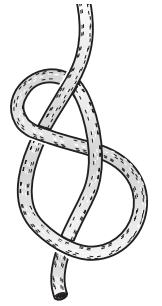
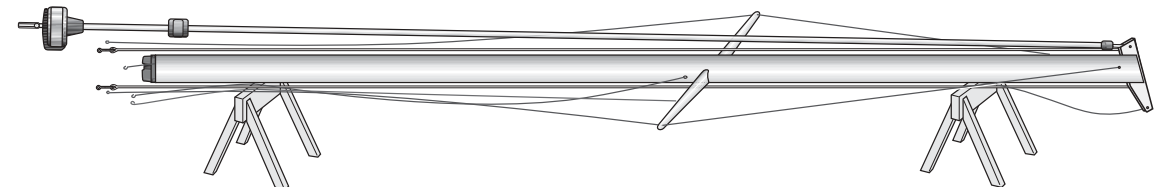

Stopper-knot (figure-of-eight).



Snap shackle with release line.

NB! Make sure that the Furlex halyard swivel is level with the sail feed before you raise the mast. Otherwise the swivel can slide down along the forestay extrusion and damage the sail feed and the person holding the Furlex bundle.

At the crane

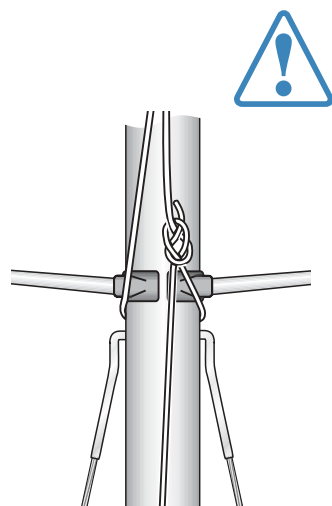
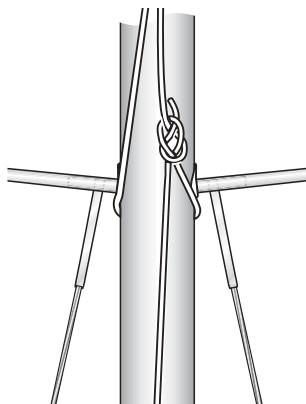

Make sure the strop does not interfere with the lower shroud attachments.

This is an operation which requires considerable care and concentration. A botched crane lift causes material damage at best, but there is a clear risk of personal injury through carelessness. Adopt the following measures:

- **Locating the yacht.** Moor the yacht so that it is stationary under the crane, with the lifting hook centred immediately forward of the T-base or deck ring.
- **External conditions.** Avoid stepping a mast in a strong wind. Ensure that onlookers are at least a mast-length away.
- **Manning.** The absolute minimum is three people. One person is appointed “captain” to take charge of the work. The captain’s task is to guide the mast over the yacht, and he/she **will not let go of the lower end of the mast until it is stayed** (for keel-stepped masts, please see page 23). Another person operates the crane, on the directions of the captain. A third person assists the captain when the mast is being lifted and swung out over the yacht. When the mast is placed on the T-base, this person attaches the shrouds and stays. Later in the book, we give a description of the order in which this is to be done for different rig types.
- Place the **mast** below the crane with the luff-groove facing downwards and top of mast facing out.
- **Locating the lifting strop.** Locate the lifting strop close to or above the mast’s centre of gravity. If the strop is placed too far down, the mast will be “top-heavy”, which

would cause a serious imbalance and make it difficult to hold the foot of the mast. Secure the strop with a strong rope carefully tied to a suitable fitting lower down the mast. For single-spreader rigs the strop is normally located underneath the spreader brackets. Make sure the strop does not interfere with the lower shroud attachments.

- **The hook** should be fitted with a locking device to prevent the lifting strop from slipping off. If this is not done, the strop must be fixed to the hook as shown in illustration on right.
- **The lifting strop** should be made from suitable rope, using a sheet bend. Check that all shrouds and stays are outside the strop. For multi-spreader rigs, if the strop is made long enough it will be possible to detach it from the hook after the mast has been stepped, without having to climb the first spreaders. However, make sure the crane is high enough to handle a long strop.
- **A keel-stepped mast** must be lifted high enough to be lowered straight down through the deck ring. Make sure the crane has sufficient vertical lift.
- **When the mast has been stayed,** move away from the mast crane as soon as possible to make room for the next yacht.

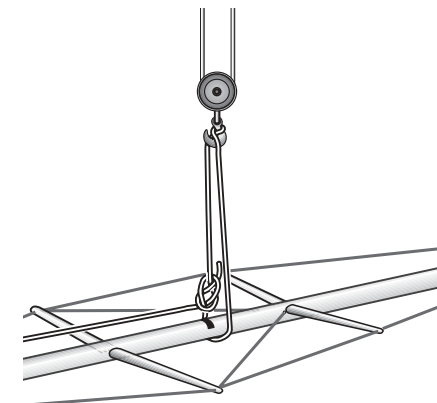

Lifting strop secured at the mast's centre of gravity.

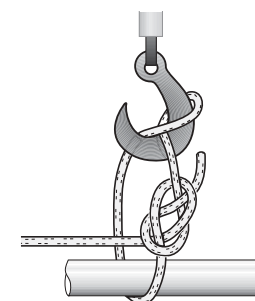

If there is no locking device, secure the line around the hook.

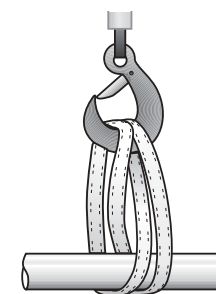

Lift hook with locking device and endless lifting strop.

Tip

- Pad the hook and the hook attachment with soft rags or foam rubber before raising the mast. This prevents damage to the mast.
- Attach a line to the lifting strop to make it easier to pull the strop down.

Keel-stepped masts

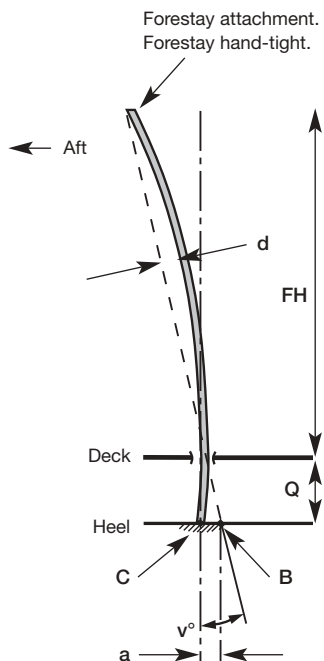

The location of the heel for rake and pre-bend of keel-stepped mast

A keel-stepped mast must take up an even curvature (convex forward) right down to the mast heel. This means that the mast heel must be located aft of a line from the forestay attachment on the mast through the centre of the deck ring (dashed line). Before you raise the mast, it is difficult to decide precisely where the mast heel should go. Start from the guide position as described below. The location of the mast heel can usually be adjusted later.

Standard configuration: Seldén calculates the standard hand-tightened forestay length for a 1° aft rake. The normal location of the heel is vertically below the centre of the deck ring which makes for 0.5% pre-bend. You can adjust both mast rake and pre-bend to suit your own ideas, based on the following principles.

Standard values

- $v = 1^\circ$
- $a = 0.017 \times Q$ (17 mm per meter Q)
- $d =$ Depth of curvature
 - 0.5% x FH
 - d must not exceed 2% (1.5% for in-mast furling).
- FH = Fore-triangle height
- Q = Distance keel to deck

The length of the forestay determines the mast rake. For 1° rake aft and a straight mast, the heel must be located $0.017 \times Q$ forward of the vertical line from the centre of the deck ring. We call this point B. The mast must not, however, be straight. It should have a certain amount of pre-bend. 0.5% of the fore-triangle height is normal. To set this amount of bend, the heel is located $0.017 \times Q$ aft of the B point. This is point C. The backstay is then tensioned to 15% of its breaking load.

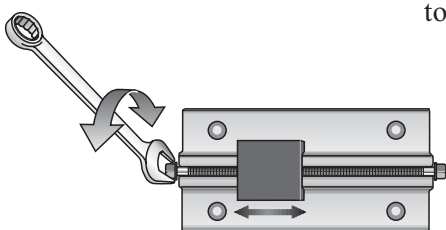

Adjustable T-base. Release rigging tension and adjust with mast still in place.



Convex underside of heel plug – distributes compressions load on the mast section.

At the crane

- Lift up the mast and lower it carefully through the deck ring. To avoid damage to the mast, cloth or thick paper can be used as protection. One person must be below deck to handle the foot of the mast. Another person should be on deck and a third at the crane. The person on deck feeds the mast through the deck ring and will relay instructions from the person below decks to the crane driver.
- Lower the mast onto the T-base. Ensure the heel is securely located fore-and-aft and in-line.
- Attach the shrouds, forestay and backstay. Tighten them by hand until the mast is held fairly steady in the deck ring.
- Take off the lifting strop and leave the crane.
- Insert the aft rubber mast wedges and lubricate the forward fixing wedge with soapy water. Tighten the nut of the forward fixing wedge in the deck ring, so that the mast is held securely.
- Unless a permanent Tie-rod arrangement is installed as a structural part of the boat, attach Seldén Tie-rod fittings, one at each side of the mast. Connect their lower parts to the mast and the bolts through the deck ring.
- Tune the standing rigging in the same way as for the equivalent deck-stepped rig.
- Tighten the Tie-rods just enough to prevent them from rattling.
- Fit the mast coat to the deck ring.



Contoured rubber chockings for perfect fit.

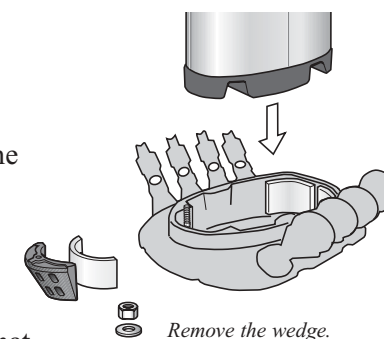

Remove the wedge.

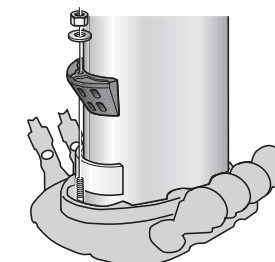

Step the mast and replace the wedge.

Continued...



Tie-rods prevent the running rigging from lifting the deck.

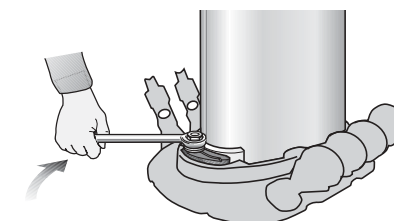

Secure the mast by tightening the nut on the wedge.

Deck ring assemblies for large masts

Mast sections: C321/171 F324/169
C365/194 F370/192

For these mast sections a two-piece deck ring assembly is used. The lower part is fitted to the deck, the upper part is supplied on the mast. A rubber o-ring is fitted between these parts. When the upper part is tightened to the lower, the o-ring compresses and secures the mast. Tie-rods are not incorporated in these deck rings as a permanent Tie-rod arrangement should always be provided by the boat builder.

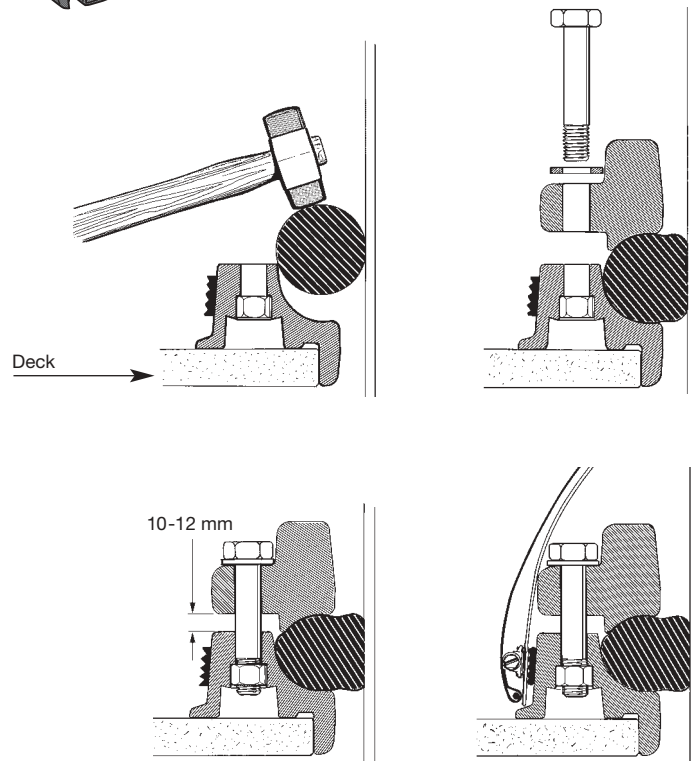
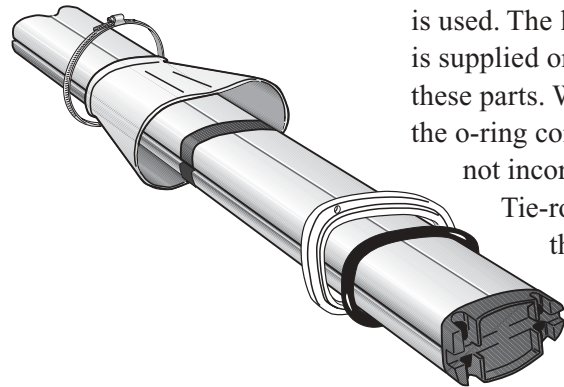

Tuning under sail

Lateral

- Due to the through-deck fit, it is not possible for a keel-stepped mast to be straight throughout its length. So, while you are sailing, check that the mast takes a smooth curve from masthead to deck. If necessary, make adjustments using the lower shrouds and intermediate shrouds.
- Reef the sail and check for lateral tuning.

Longitudinal

- While sailing, check the fore-and-aft trim of the mast. Apart from the location of the mast foot, this is also affected by the backstay/forestay, inner forestay/check-stays, double lower shrouds or aft lower shroud + baby stay. The mast must have a slight positive pre-bend at the spreader area.
- For keel-stepped masts, it is important that the lower part of the mast makes a fair positive curve, not an S-shaped curve. Sight up the mast from deck level. It may be necessary to slacken the rigging, adjust the heel position on the T-base and reset the rigging.
- With an increasing load on the forestay, the masthead will want to move forwards, with the risk of a negative bend. This must be prevented. Even if the masthead in its original position is well aft, it is usually necessary to use some sort of backstay tensioner to counteract this movement.
- In other respects, the tuning is checked in the same way as for the corresponding deck-stepped rig type.

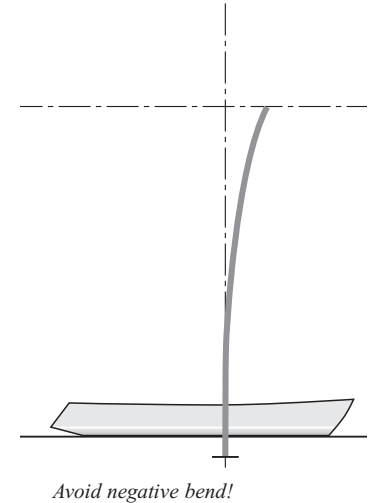
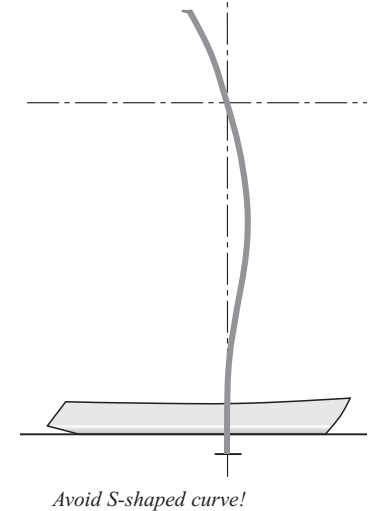

Alternative rigging of jib furling system

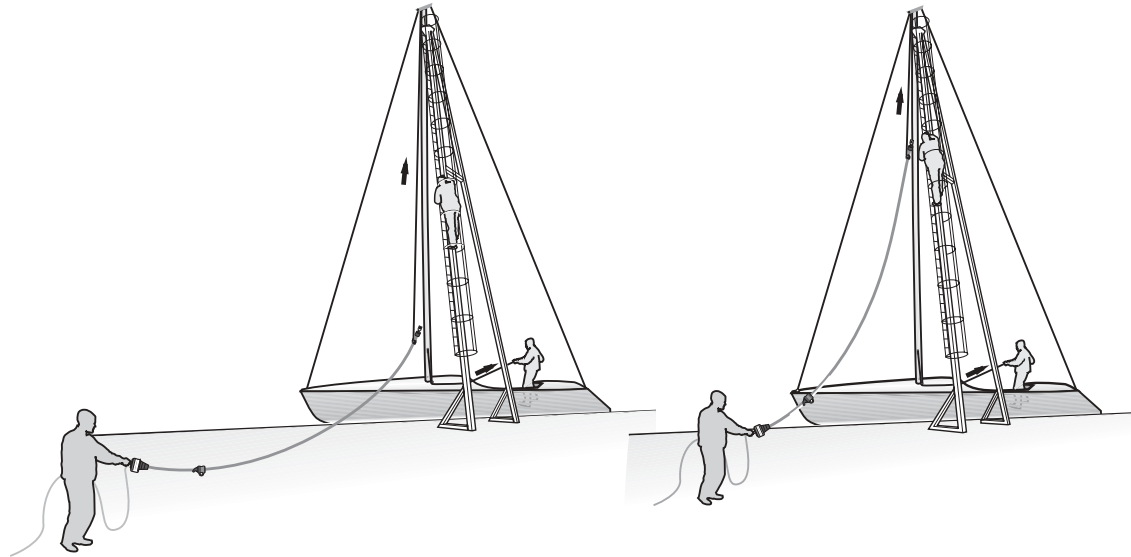

Normally, the jib furling system is placed on the forward side of the mast when the mast is being lifted by the crane. One person is detailed to prevent the system damaging the mast or yacht. The extrusion used in the furling system can cope with large radius bends without any problems, but may break in the event of uncontrolled buckling.

If you feel that the jib furling system will be in the way during the mast lift, there is an alternative approach. This takes longer, but simplifies mast-stepping. It requires access to a crane fitted with a ladder from which you can reach the forestay fitting on the mast. The installation can also be done from a bosun's chair.

- Lay the furling system on the dock beside the crane.
- Step the mast without the jib furling system, and use the genoa halyard as a temporary forestay. The halyard is tied

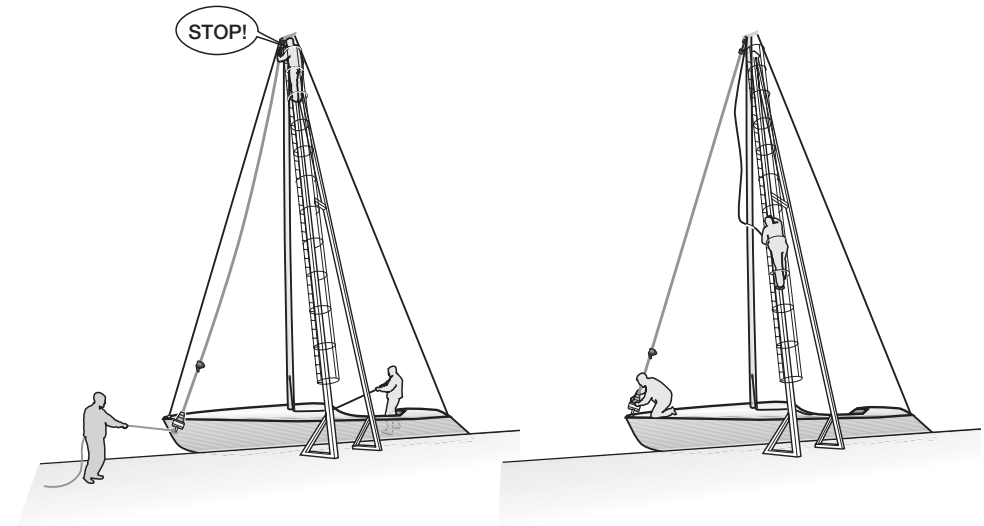

to the outermost (as seen from the dock) mooring cleat in the bows. Do not rely on key shackles or snap shackles.

- Tighten the genoa halyard, and ease off the backstay/cap shroud to bring the forestay attachment fitting forward.
- Tie the spinnaker halyard to the top of the jib furling system using a non-slip knot, according to illustration.
- One person now climbs the ladder on the crane until the forestay attachment can be reached. Another person raises the jib furling system using the spinnaker halyard. A third person lifts the lower end of the jib furling system to prevent it dragging along the ground.
- The furler is attached to the mast, and the person aloft brings the spinnaker halyard down.
- The lower end of the system is attached to the forestay deck fitting.
- Cast off the genoa halyard and tighten the backstay/cap shrouds.

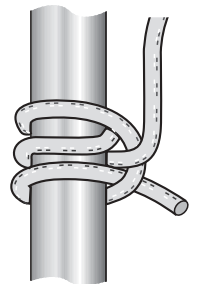

Non-slip knot.

Tensioning the cap shrouds

Wire diameter, mm	Breaking load, kN / lbs	
Ø 3	8	1,770
Ø 4	14	3,090
Ø 5	22	4,860
Ø 6	31	6,845
Ø 7	43	9,490
Ø 8	56	12,360
Ø 10	88	19,425
Ø 12	126	27,815
Ø 14	171	37,750
Ø 16	216	47,680

The breaking loads for various dimensions of 1 x 19 strand wire.

It is a fundamental requirement for all rig types that the cap shrouds are correctly tensioned. The cap shrouds are adjusted at the dockside, but final tuning is done while sailing. The table beside applies to standing rigging using 1 x 19 stainless wire. This is the most commonly used material for standing rigging.

Your aim should be to tension the cap shrouds to 15-20% of the breaking load (the final check on tuning should be left until you are under sail). Then you know that the lateral staying is optimal both for the security of the rig and for sailing performance.

There are measuring instruments of greater or lesser reliability for this purpose on the market. Seldén has developed a simple method of obtaining the information you need with material you probably already have. What you need to know is:

- All 1 x 19 stainless wire stretches under load, but returns to its original length when the load is removed. 1 mm stretch per 2 m wire is equivalent to 5% of the breaking load, irrespective of the diameter of the wire.
- A grp hull, on the other hand, changes its shape permanently when the rig is put under load. This makes it necessary to set up the rigging again after some time. This applies particularly to new yachts.
- At the dockside, both cap shrouds always have the same load. If you tension the starboard shroud, the port shroud is affected to precisely the same extent.

“The folding rule method”

The following materials are required:

1. A 2 metre long measuring rod (a folding rule is recommended)
2. Adhesive tape
3. Vernier callipers

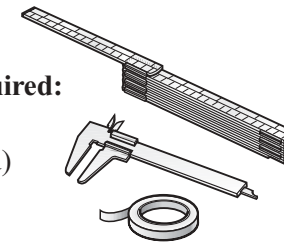

- Start with the cap shrouds only hand-tight. The rig is stayed with the lower shrouds and the forestay and backstay.
- Tape the upper end of the folding rule to the starboard cap shroud. The lower end of the folding rule must be approximately 5 mm above the upper end of the wire terminal. Measure the distance between terminal and folding rule exactly. This is index 0, let's call it point A.
- Tension the starboard cap shroud until the distance is $A + 1.5$ mm between the terminal and the folding rule. Measure using the vernier callipers.
- Leave the folding rule attached to the starboard shroud, and move across to the port side and tension the shroud rigging screw the equivalent amount.
- At intervals, check the starboard side to see how much the folding rule has moved from the end terminal. When there is a gap of $A + 3$ mm, the cap shrouds are tensioned to 15% of the breaking load of the wire ($3 \times 5\% = 15\%$).

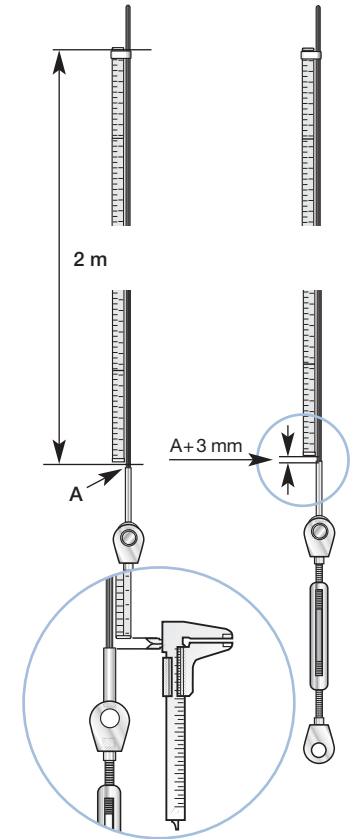

Hint! Count how many turns on the rigging screw corresponds to 1 mm elongation (5% of the breaking load). Make a note of it. This is useful to know if you ever need to tension “another 5%”.

If the mast is not straight, adjust the lower shrouds, intermediate shrouds etc. There is more information on this in the chapter dealing with your rig type.

The folding rule method can be used on other stays, such as the backstay and forestay (without jib furling system). It can also be used for Dyform- or rod rigging, but please take the difference in stretch into account compared to 1 x 19 wire.

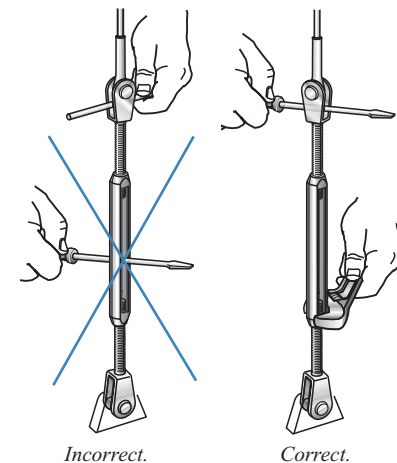

Stretch per 2 meter

	1 x 19 wire	Dyform	Rod
5% of breaking load	1 mm	0.95 mm	0.7 mm

Tuning for safety

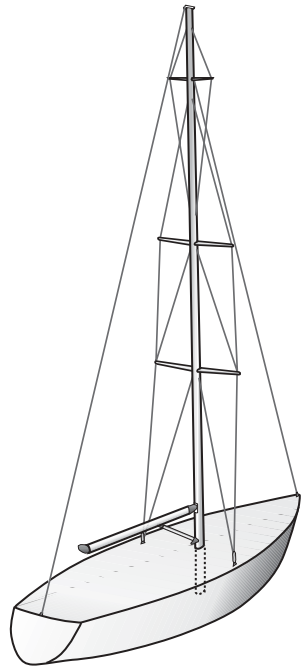

The rig is tuned for two reasons. Safety and speed. There are fundamental rules governing rig safety which apply to all rig types. Others are specific to fractional and masthead rigs respectively.

Factors which have a positive effect on mast stability:

Lateral

- Correct adjustment of the lateral rigging. The aim is to achieve a straight mast in the lateral plane during sailing. A keel-stepped mast, however, must have an even curve.

Longitudinal

- **Fractional rig:** A tight (not necessarily tensioned) backstay reduces the risk of the mast inverting. Inversion means that the mast creates a negative bend (the spreader area moving aft) until the mast buckles backwards. When the spreader area tries to move aft, the masthead wants to move forward, but this movement is prevented by a tight backstay.
- **Masthead rig:** Correctly tuned babystay or forward lower shrouds creating a positive pre-bend of the mast. This prevents inversion even if the backstay is slackened.

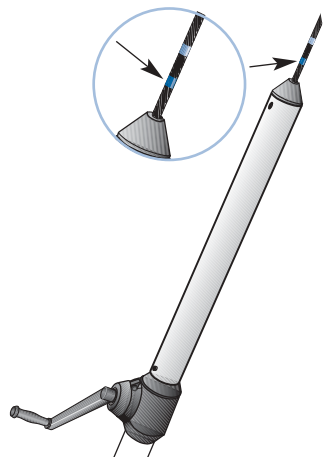

Mark the backstay with two pieces of tape at normal- and maximum load. The tape markers will enable you to re-tension the stay accurately.

In addition ...

- A stiff hull which resists deformation. This prevents the tension in shrouds and stays being “wasted” in hull deformation.



Factors which have a negative effect on mast stability	Action
<i>Lateral rigging adjusted incorrectly. The most common fault is that the rigging is not tight enough.</i>	Adjust the lateral rigging in accordance with the instructions before leaving the dockside, and then check under sail.
<i>Excessive mast bend. It must not exceed 2% of the height of the fore-triangle. For in-mast furling, the limit is 1.5%.</i>	Reduce bend by easing off the backstay and/or tension checkstays. Pre-bend is adjusted by the interplay between the baby stay and the aft lower shroud or the forward/aft lower shrouds. On keel-stepped masts, the fore-and-aft location of the mast heel can be adjusted.
<i>Sailing or motoring in high seas. The mast is subject to acceleration and deceleration forces in the fore-and-aft direction, “pitching”.</i>	These forces are caused by the weight and movement of the mast. Damage is avoided if the rigging is adjusted to prevent movement of the mast. This reduces dynamic stresses on the whole rig.
<i>Reefing the mainsail until the head-board is considerably below the forestay fitting. There is a risk that the mast will take on a negative bend.</i>	Give the mast a positive pre-bend by adjusting the backstay, baby stay/forward lower stay and any inner forestay.
<i>Pressure from the spinnaker pole on a broad reach (the spinnaker pole is close to the forestay).</i>	The mast pre-bend is important. Adjust the fore lower shroud or baby stay so that these counteract the acting pressure from the spinnaker pole.
<i>Pressure from the spinnaker pole if it hits the water during heavy rolling when running.</i>	Alter the lead of the spinnaker sheet using a barber hauler to prevent the spinnaker oscillating. Tighten the spinnaker pole lift. Take in the spinnaker.
<i>Fractional rig: Runners in combination with aft-swept spreaders. When a runner is tightened, it pulls the mast aft and to windward. Forestay tension increases, and it stretches accordingly. Lateral rigging tension and tuning will be affected. This increases the risk of the mast buckling aft (inverting).</i>	Adjust the lateral rigging in accordance with the instructions before leaving the dockside, tension the backstay, and then check under sail.
<i>Hull not stiff enough. The rigging wire itself has negligible permanent deformation after loading. If, however, the hull gives too much under the rigging loads, tuning will be altered. All hulls, irrespective of construction material, will have more or less elastic deformations under load. GRP hulls take on a permanent deformation after a certain time under load.</i>	There is not much you can do about it, other than be aware that it happens and check the tuning regularly.



Masthead rig with one set of in-line spreaders, deck-stepped mast, single aft lower shrouds and baby stay

(Masthead rig with one set of swept spreaders and single aft lower shrouds and baby stay, is tuned with the same method)

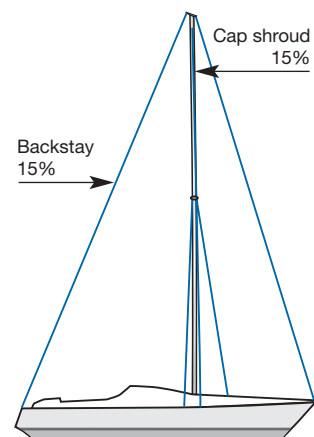

At the crane

- Read the “At the crane” section on pages 20-21.
- Lift the mast and place it on the T-base.
- Attach the cap shrouds, backstay and forestay.
- Tighten the cap shrouds, forestay and backstay hand-tight so that the mast is stayed both laterally and longitudinally.
- Lower the lifting strop and attach the lower shrouds and baby stay. Hand-tighten and move the yacht away from the crane.

Tuning

- Check the mast rake. If necessary, adjust using toggles on the forestay.
- Tension the cap shrouds to 15% of the breaking load of the wire. See the “folding rule method”, page 29.
- Straighten the mast using the lower shrouds. If necessary, adjust the rigging screws for the cap shrouds without changing the cap shrouds tension (slacken one rigging screw by exactly the same amount as you tighten the other one). Check that the mast is straight by sighting up the luff groove, all the way up from deck level.
- Give the mast a slight positive pre-bend by tightening the baby stay.
- Tension the backstay to 15% of the breaking load of the wire. Over a short period (a few hours) the load may be increased, but not to more than 30% of the breaking load of the wire. To achieve this loading, you will need a backstay tensioner. Make two marks on this so that you

know when the normal (15%) and maximum (30%) loads have been reached. Use the “folding rule method” to find the correct setting. Since the backstay makes a wider angle with the mast, the forestay load will be about 40% of the breaking load of the wire when you put the “maximum load” on the backstay.

Tuning under sail

- Sail the yacht and check that the cap shrouds do not begin to slacken until about a 20° angle of heel is reached.
- While sailing, check that the mast is straight laterally. Adjust if necessary using the lower shrouds.
- Reef the sail and check for lateral straightness. If the deviation from the straight line is greater than 5 mm, the lower shrouds must be adjusted.
- While sailing, check the longitudinal trim of the mast. The mast must have a slight positive bend at the spreader area. Sight up the mast from deck level. With an increasing load on the forestay, the masthead will want to move forward, with the risk of a negative bend. This must be prevented. Even if the masthead in its original position is well aft, it is usually necessary to use some sort of backstay tensioner to counteract this movement.
- When you are satisfied with the tuning, lock the rigging screws.
- A new rig on a new yacht will need adjusting after sailing for some time. When the tuning at the end of the first season is satisfactory, mark the setting on the rigging screws. Enter your figures on page 80. This makes it easy to tune the rig at the start of the next season.

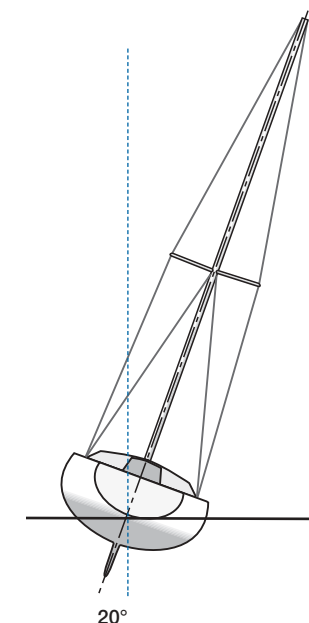

Masthead rig with one set of in-line spreaders, deck-stepped mast, forward and aft lower shrouds

(Masthead rig with one set of swept spreaders and forward and aft lower shrouds, is tuned with the same method)

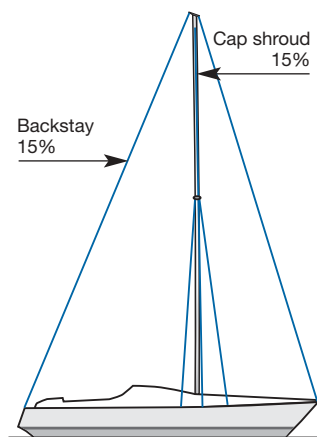

At the crane

- Read the “At the crane” section on pages 20-21.
- Lift the mast and place it on the T-base.
- Attach the cap shrouds, backstay and forestay.
- Tighten the cap shrouds, forestay and backstay hand-tight so that the mast is stayed both laterally and longitudinally.
- Lower the lifting strop and attach the lower shrouds. Hand-tighten and move the yacht away from the crane.

Tuning

- Check the mast rake. If necessary, adjust using toggles on the forestay.
- Tension the cap shrouds to 15% of the breaking load of the wire. See the “folding rule method”, page 29.
- Straighten the mast using the forward lower shrouds. If necessary, adjust the rigging screws for the cap shrouds without changing the cap shrouds tension (slacken one rigging screw by exactly the same amount as you tighten the other one). Check that the mast is straight by sighting up the luff groove, all the way up from deck level.
- Give the mast a slight positive pre-bend using the interplay between the forward and aft lower shrouds. The job of the aft lower shrouds is to reduce the pre-bend to the amount originally determined.
- Tension the backstay to 15% of the breaking load of the wire. Over a short period (a few hours) the load may be increased, but not to more than 30% of the breaking load of the wire. To achieve this loading, you will need

a backstay tensioner. Make two marks on this so that you know when the normal (15%) and maximum (30%) loads have been reached. Use the “folding rule method” to find the correct setting. Since the backstay makes a wider angle with the mast, the forestay load will be about 40% of the breaking load of the wire when you put the “maximum load” on the backstay.

Tuning under sail

- Sail the yacht and check that the cap shrouds do not begin to slacken until about a 20° angle of heel is reached.
- While sailing, check that the mast is straight laterally. Adjust if necessary using the forward lower shrouds.
- Reef the sail and check for lateral straightness. If the deviation from the straight line is greater than 5 mm, the lower shrouds must be adjusted.
- While sailing, check the longitudinal trim of the mast. The mast must have a slight positive bend at the spreader area. Sight up the mast from deck level. With an increasing load on the forestay, the masthead will want to move forward, with the risk of a negative bend. This must be prevented. Even if the masthead in its original position is well aft, it is usually necessary to use some sort of backstay tensioner to counteract this movement.
- When you are satisfied with the tuning, lock the rigging screws.
- A new rig on a new yacht will need adjusting after sailing for some time. When the tuning at the end of the first season is satisfactory, mark the setting on the rigging screws. Enter your figures on page 80. This makes it easy to tune the rig at the start of the next season.

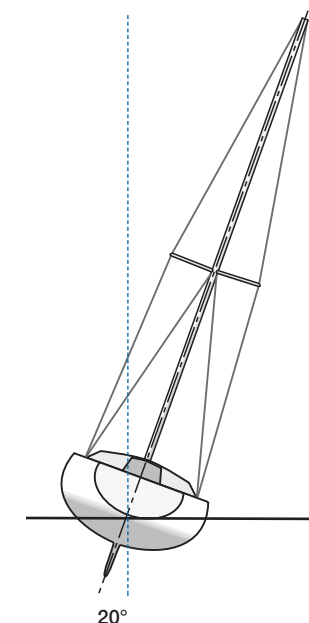

Masthead, multi-spreader rig, swept spreaders, deck-stepped mast, forward and aft lower shrouds. Alternatively baby stay and aft lower shrouds.

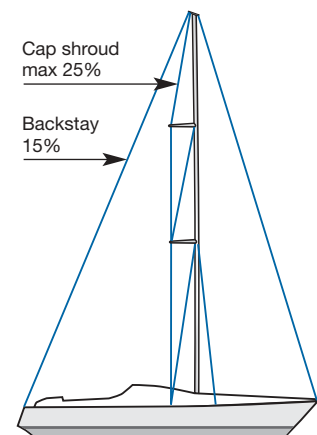

This type of rig is very demanding on the sailor, since it is complex to tune and to handle. In general, this type of rig needs more tension in the shrouds than a rig with in-line spreaders.

At the crane

- Read the “At the crane” section on pages 20-21.
- Lift the mast and place it on the T-base.
- Attach the cap shrouds, backstay, forestay and lower shrouds.
- Tighten the cap shrouds, forestay and backstay hand-tight so that the mast is stayed both laterally and longitudinally.
- Lower and remove the lifting strop. Move the yacht away from the crane.

Tuning

- Check the mast rake. Adjust if necessary using toggles on the forestay.
- Tension the backstay to 15% of the breaking load of the wire. This puts the forestay under tension corresponding to about 20% of its breaking load. Since the backstay makes a wider angle with the mast, the forestay load will be greater. Make a mark on your backstay tensioner so that you will always know when normal load (15%) has been achieved. Use the “folding rule method”, see page 29, to find the correct setting. Leave the folding rule on the backstay.

- Tension the cap shrouds to 15% of the breaking load of the wire. See the “folding rule method”. Count and make a note of the number of turns on both the port and starboard rigging screws required to increase the tension by 5% (1 mm stretch). Leave the folding rule on the shroud.
- Roughly straighten the mast using the lower and intermediate shrouds. Note that the intermediate shroud tension should be fairly low at this stage, only sufficient to keep the mast straight. Check that the mast is straight by sighting up the luff groove, all the way up from deck level.
- Increase backstay tension to 20% of its breaking load. Mark the setting on the backstay tensioner at this pre-tension level as well. The cap shrouds tension has now been reduced since the masthead has been pulled downwards/aft by the backstay.
- Increase the cap shrouds tension to 20% of the breaking load of the wire.
- Tune the mast straight again using the lower shrouds and the intermediate shrouds.
- Slacken the backstay to 15% of its breaking load, in other words, to the first mark.
- Now check the cap shrouds tension. It should not exceed 25% of the breaking load of the wire.
- On this type of rig, forestay tension is affected by both backstay and cap shrouds. With 20% of the breaking load in the backstay and cap shrouds respectively, the load on the forestay is about 40% of the breaking load.

Continued...

Continued: Masthead, multi-spreader rig, swept spreaders, deck-stepped mast, forward and aft lower shrouds. Alternatively baby stay and aft lower shrouds.

Tuning under sail

- At about a 20° angle of heel and maximum pre-tension on the backstay, the lee cap shroud must not be slack. If it is, increase the pre-tension, but not to more than 25% of the breaking load of the wire (the same number of turns on the rigging screws as per your previous note).
- Tune the mast straight laterally using the lower shrouds and the intermediate shrouds.
- Reef the sail and check that the mast is straight laterally. If it deviates from the straight by more than 5 mm, the lower shrouds must be adjusted.
- While sailing, check the mast's fore-and-aft tuning. The mast should have a slight forward bend at the spreader area. Sight along the mast from deck level. Adjust if necessary using the lower shrouds.
- Check the tune for different backstay tensions and different sail combinations (reef).

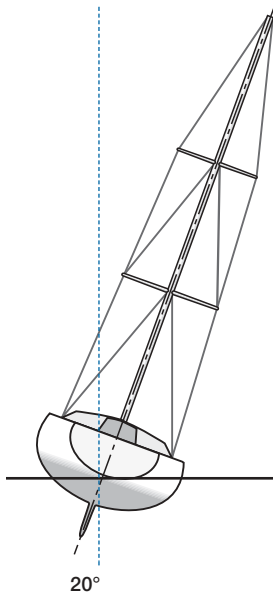

To ensure good fore-and-aft stability for this type of rig, it is very important that the leeward cap shroud is tight.

This high level of pre-tension will generate plastic deformation on all grp hulls. As far as strength is concerned, the hull should be able to support these loads, but the deformation will make it necessary to check the tuning while sailing. This is particularly important when the yacht is new and at the start of every season.

Masthead, multi-spreader rig, in-line spreaders, deck-stepped mast, forward and aft lower shrouds. Alternatively, baby stay and aft lower shrouds.

This type of rig is often fitted with an inner sail-carrying forestay, a cutter stay. The location of the cutter stay determines whether “running backstays” (also called “runners”) are needed to provide sufficient longitudinal stability as well as to provide the necessary cutter stay tension. We recommend runners if the cutter stay is attached more than 6% of the fore-triangle height below the ordinary forestay fitting.

At the crane

- Read the “At the crane” section on pages 20-21.
- Lift the mast and place it on the T-base.
- Attach the cap shrouds, backstay, forestay and all four lower shrouds.
- Tighten the cap shrouds, forestay and backstay hand-tight so that the mast is stayed both laterally and longitudinally. Attach the lower shrouds.
- Lower and remove the lifting strop. Move the yacht away from the crane.

Tuning

- Check the mast rake. Adjust if necessary using toggles on the forestay.
- Tension the cap shrouds to 15% of the breaking load of the wire. See the “folding rule method”, page 29.
- Straighten the mast using the forward lower shrouds and the intermediate shrouds. If necessary, adjust the rigging screws for the cap shrouds without changing the cap shrouds tension (slacken one rigging screw by exactly the same amount as you tighten the other one). Check that the mast is straight by sighting up the luff groove, all the way up from deck level.

Continued...

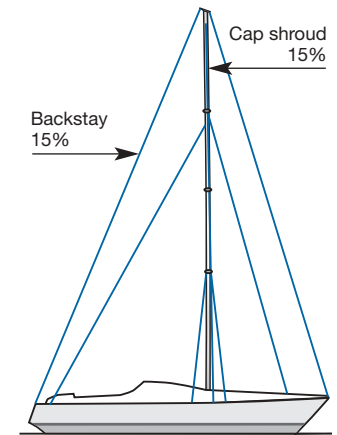

Continued: Masthead, multi-spreader rig, in-line spreaders, deck-stepped mast, forward and aft lower shrouds. Alternatively, baby stay and aft lower shrouds.

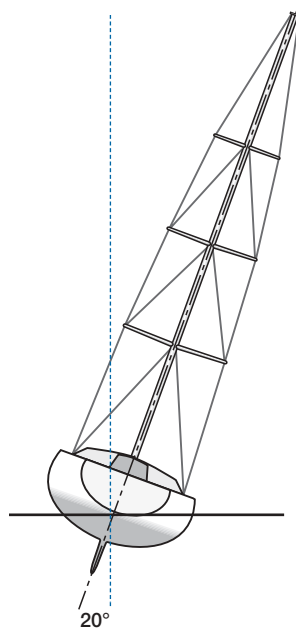

- Give the mast a slight positive pre-bend using the interplay between the forward and aft lower shrouds. The job of the aft lower shrouds is to reduce the bend to the amount originally determined.
- Tension the backstay to 15% of the breaking load of the wire. Over a short period (a few hours) the load may be increased, but not to more than 30% of the breaking load of the wire. To achieve this loading, you will need a backstay tensioner. Make two marks on this so that you know when the normal (15%) and maximum (30%) loads have been reached. Use the “folding rule method” to find the correct setting. Since the backstay makes a wider angle with the mast, the forestay load will be about 40% of the breaking load of the wire when you put the “maximum load” on the backstay.

Tuning under sail

- Sail the yacht and check that the cap shrouds do not begin to slacken until about a 20° angle of heel.
- While sailing, check that the mast is straight laterally. Adjust this if necessary using the forward lower shrouds and intermediate shrouds.
- Reef the sail and check the mast for lateral straightness. If the deviation from the straight line is greater than 5 mm, the lower shrouds or the intermediate shrouds must be adjusted.
- While sailing, check the longitudinal trim of the mast. The mast must have a slight positive bend at the spreader area. Sight up the mast from deck level. Adjust if necessary by tuning the interplay between the aft- and forward

lower shrouds or cutter stay/runner. With an increasing load on the forestay, the masthead will want to move forwards, with the risk of a negative bend. This must be prevented. Even if the masthead in its original position is well aft, it is usually necessary to use some sort of backstay tensioner to counteract this movement.

- When you are satisfied with the tuning, lock the rigging screws.
- A new rig on a new yacht will need adjusting after sailing for some time. When the tuning at the end of the first season is satisfactory, mark the setting on the rigging screws. Enter your figures on page 80. This makes it easy to tune the rig at the start of the next season.

Cutter stay and runners

A cutter stay in combination with runners also affects the forward bend of the mast. Runners are tensioned with winches and/or tackles to a maximum of 30% of their breaking load.

Fractional rig, one set of swept spreaders, single aft lower shrouds, deck-stepped mast

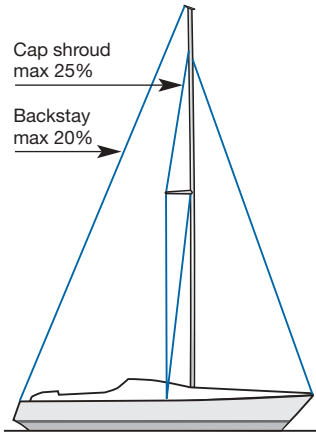

In general, this type of rig needs more tension in the shrouds than a rig with in-line spreaders. The tension in the forestay is affected by three components;

1. The cap shrouds
2. The backstay
3. The sheeting of the mainsail

At the crane

- Read the “At the crane” section on pages 20-21.
- Lift the mast and place it on the T-base.
- Attach the cap shrouds, backstay, and forestay.
- Tighten the cap shrouds, forestay and backstay temporarily so that the mast is stayed both laterally and longitudinally.
- Lower the lifting strop and remove it. Attach the lower shrouds. Move the yacht away from the crane.

Tuning

- Check the mast rake. Adjust if necessary using toggles on the forestay.
- Tension the cap shrouds to 15% of the breaking load of the wire. See the “folding rule method”, page 29. Leave the folding rule on the shroud.
- Roughly straighten the mast using the lower shrouds. Check that the mast is straight by sighting up the luff groove, all the way up from deck level.
- Increase the cap shrouds tension to 20% of the breaking load of the wire. Count and make a note of the number of turns on both the port and starboard rigging screws required to increase the tension by 5% (1 mm stretch).
- Tune the mast straight again using the lower shrouds.
- Tension the backstay hard, but not exceeding 20% of the breaking load of the wire. Make a mark on your backstay tensioner or tackle so that you will always

know when this normal load has been achieved. Use the “folding rule method” to find the correct setting. This will reduce the tension of the cap shrouds.

- Increase the cap shroud tension back to 20% of the breaking load of the wire.
- Slacken the backstay completely.
- Now check the cap shrouds tension. It should not exceed 25% of the breaking load of the wire.

Tuning under sail

- At about a 20° angle of heel and maximum pre-tension (20%) on the backstay, the leeward cap shroud must not be slack. If it is, increase the shrouds pre-tension, but not to more than 25% of the breaking load of the wire (the same number of turns on the rigging screws as per your previous note).
- Tune the mast straight laterally using the lower shrouds.
- Check the tune for different backstay tensions and different sail combinations (reef).
- The backstay must not be allowed to completely slacken at any time. If the masthead is able to move forwards, the mast is in danger of buckling aft. If using a tackle, put a stopper-knot in the tail to limit the reduction in backstay tension.

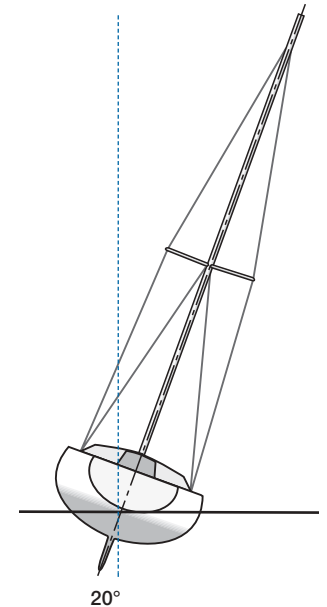

20°

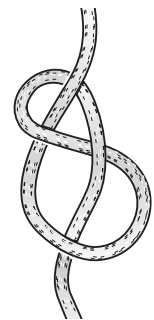

Stopper-knot (figure-of-eight).

To ensure good fore-and-aft stability for this type of rig, it is very important that the leeward cap shroud is tight.

This high level of pre-tension will generate plastic deformation on all grp hulls. As far as strength is concerned, the hull should be able to support these loads, but the deformation will make it necessary to check the tuning while sailing. This is particularly important when the yacht is new and at the start of every season.

Fractional, multi-spreader rig, swept spreaders, deck-stepped mast

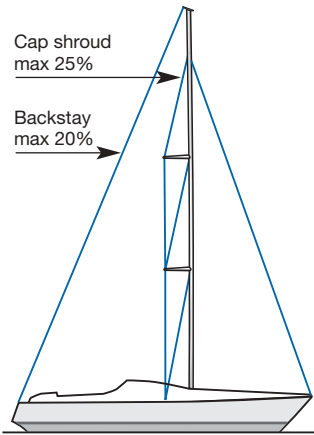

This type of rig is very demanding on the sailor, since it is complex to tune and to handle. In general, this type of rig needs more tension in the shrouds than a rig with in-line spreaders. The tension in the forestay is affected by three components;

1. The cap shrouds
2. The backstay
3. The sheeting of the mainsail

At the crane

- Read the “At the crane” section on pages 20-21.
- Lift the mast and place it on the T-base.
- Attach the cap shrouds, backstay, forestay and lower shrouds.
- Tighten the cap shrouds, forestay and backstay hand-tight so that the mast is stayed both laterally and longitudinally.
- Lower and remove the lifting strop. Move the yacht away from the crane.

Tuning

- Check the mast rake. Adjust if necessary using toggles on the forestay.
- Tension the cap shrouds to 15% of the breaking load of the wire. See the “folding rule method”, page 29. Leave the folding rule on the shroud.
- Roughly straighten the mast using the lower and intermediate shrouds. Note that the intermediate shroud tension should be fairly low at this stage, only sufficient to keep the mast straight. Check that the mast is straight by sighting up the luff groove, all the way up from deck level.
- Increase the cap shrouds tension to 20% of the breaking load of the wire. Count and make a note of the number

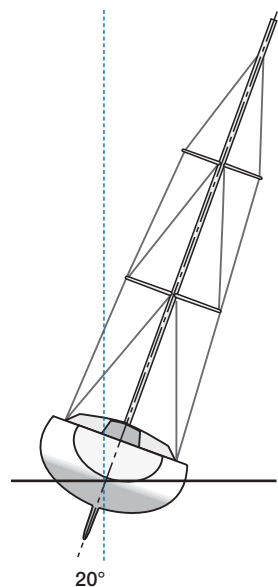

of turns on both the port and starboard rigging screws required to increase the tension by 5% (1 mm stretch).

- Tune the mast straight again using the lower shrouds and the intermediate shrouds.
- Tension the backstay hard, but not exceeding 20% of the breaking load of the wire. Make a mark on your backstay tensioner so that you will always know when this normal load has been achieved. Use the “folding rule method” to find the correct setting. This will reduce the tension of the cap shrouds.
- Increase the cap shroud tension back to 20% of the breaking load of the wire.
- Slacken the backstay completely.
- Now check the cap shrouds tension. It should not exceed 25% of the breaking load of the wire.

Tuning under sail

- At about a 20° angle of heel and maximum pre-tension (20%), on the backstay, the leeward cap shroud must not be slack. If it is, increase the pre-tension, but not to more than 25% of the breaking load of the wire (the same number of turns on the rigging screws as per your previous note).
- Tune the mast straight laterally using the lower shrouds and the intermediate shrouds.
- Check the tune for different backstay tensions and different sail combinations (reef).
- The backstay must not be allowed to completely slacken at any time. If the masthead is able to move forwards, the mast is in danger of buckling aft. If using a tackle, put a stopper-knot in the tail to limit the reduction in backstay tension.

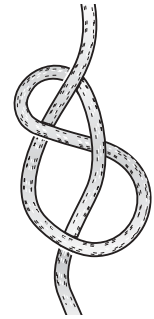

Stopper-knot (figure-of-eight).

To ensure good fore-and-aft stability for this type of rig, it is very important that the leeward cap shroud is tight.

This high level of pre-tension will generate plastic deformation on all grp hulls. As far as strength is concerned, the hull should be able to support these loads, but the deformation will make it necessary to check the tuning while sailing. This is particularly important when the yacht is new and at the start of every season.

Fractional, in-line multi-spreader rig, deck-stepped mast, forward and aft lower shrouds. Alternatively baby stay and aft lower shrouds.

(Equivalent one-spreader rig is tuned in the same way)

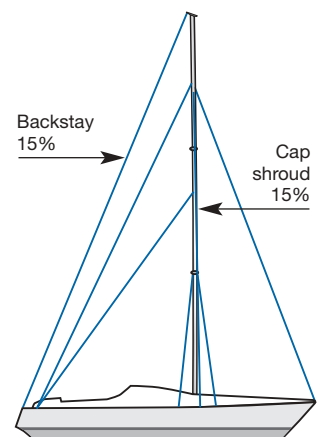

Runners are required to give sufficient longitudinal stability, and to obtain the required forestay tension. The backstays must be located as near the centre line of the hull as possible so as not to affect the lateral tuning. This type of rig is also found with single lower shrouds, in-line, and in that case checkstays are recommended to prevent excessive mast bend.

At the crane

- Read the “At the crane” section on pages 20-21.
- Lift the mast and place it on the T-base.
- Attach the cap shrouds, backstay, forestay and lower shrouds.
- Tighten the cap shrouds, forestay, backstay and lower shrouds hand-tight so that the mast is stayed both laterally and longitudinally.
- Lower and remove the lifting strop. Move the yacht away from the crane.

Tuning

- Tension both runners 15% of their breaking load.
- Check the mast rake. Adjust if necessary using toggles on the forestay.
- Tension the cap shrouds to 15% of the breaking load of the wire. See the “folding rule method”, page 29.
- Straighten the mast using the aft lower shrouds and the intermediate shrouds. If necessary, adjust the rigging screws for the cap shrouds without changing the cap shrouds tension (slacken one rigging screw by exactly the same amount as you tighten the other one). Check

that the mast is straight by sighting up the luff groove, all the way up from deck level.

- Tension the backstay 15% of its breaking load.
- Give, if necessary, the mast a slight positive bend using the interplay between the aft and forward lower shrouds. The job of the forward lower shrouds is to prevent the spreaders moving aft if there is little load on the backstay.

Tuning under sail

- Sail the yacht with backstay (15%) and windward runner set to 15-30% of its breaking load. Check that the cap shrouds do not begin to slacken until about a 20° angle of heel.
- While sailing, check that the stayed section of the mast is straight laterally. Adjust if necessary using the aft lower shrouds and intermediate shrouds. The unstayed bare upper section will bend to leeward under sail, and you cannot compensate for this.
- Reef the sail and check for lateral straightness. If the deviation from the straight line is greater than 5 mm, the lower shrouds and/or intermediate shrouds must be adjusted.
- While sailing, both with full and reefed main, check the longitudinal trim of the mast. The mast must have a slight positive bend at the spreader area. Sight up the aft side of the mast from deck level. Under no circumstances must the top of the mast be allowed to move forward. If it does, there is a risk of the mast buckling aft (inverting). The backstay and forward lower stays must always be sufficiently tensioned to counteract this. If using a tackle to tension the backstay, put a stopper-knot in the tail to limit the available tension reduction. The risk of buckling should be kept in mind when checkstays are used.
- When you are satisfied with the tuning, lock the rigging screws.

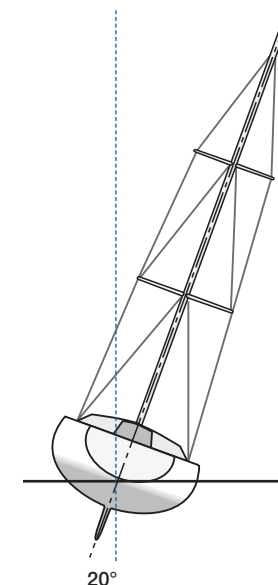

Stopper-knot (figure-of-eight).

Continued...

Continued: Fractional, in-line multi-spreader rig, deck-stepped mast, forward and aft lower shrouds. Alternatively baby stay and aft lower shrouds. (Equivalent one-spreader rig is tuned in the same way.)

- A new rig on a new yacht will need adjusting after sailing for some time. When the tuning at the end of the first season is satisfactory, mark the setting on the rigging screws. This makes it easy to tune the rig at the start of the next season.
- Forestay tension is adjusted using the runners. The windward runner must always be tight. Very tight when beating. Mark your runner tackles at the positions which give the best trim on different points of sail.

19/20 rig and similar

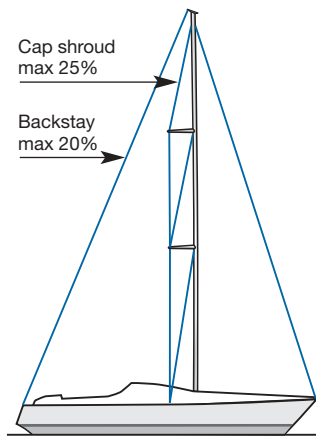

This is a fractional rig with a short distance between the masthead and the forestay fitting, which is a good compromise between the well-tensioned forestay of the masthead rig and the fractional rig's flexible mast and easily-reefed, efficient mainsail. Runners are not required to obtain sufficient forestay tension. Making the right choice for the length of the unsupported mast in relation to the fore-triangle height and longitudinal stiffness of the mast section gives an optimal mast bend both in hard winds (high forestay loads and considerable mast bend/flat mainsail) and in light winds. The spreaders may be in-line or swept aft. The forestay tension and the mast bend/mainsail fullness are varied through adjusting the backstay tension. The backstay must not be eased completely for the reasons given below.

At the crane

- Follow the instructions for the appropriate fractional rig.

Tuning

- Follow the instructions for the appropriate fractional rig. For rigs fitted with double lower shrouds, tuning will be carried out using the aft lower shrouds when the forestay has been tensioned to the maximum permitted load. The aft lower shrouds affect both the lower part of the longitudinal mast curve (limit bend) and in-line tuning (straighten mast). The forward lower shrouds are tensioned only enough to prevent the mast buckling aft (inverting). This is particularly important when sailing in rough seas.

Tuning under sail

- Follow the instructions for the appropriate fractional rig.
- For rigs with single (aft) lower shrouds, it is absolutely vital never to let the masthead move forward creating a negative bend of the mast. **The backstay must always be tensioned to prevent this.** Without forward lower shrouds or a baby stay, there is nothing but the backstay, and possibly swept spreaders, to prevent the mast inverting. A mast which inverts usually suffers serious damage, and in the worst case, the rig may be lost.

If you are using a tackle to tension your backstay, put a stopper-knot in the tail to limit the reduction in backstay tension.

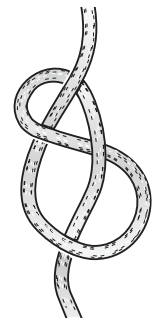

Stopper-knot (figure-of-eight).

B & R rig (Bergström & Ridder) without backstay

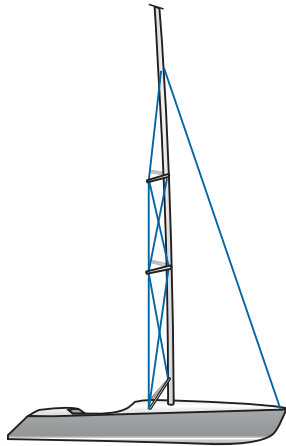

B & R characteristics:

- The spreaders are swept 30°, considerably more than on conventional rigs.
- Reverse diagonals (RD) are used to induce pre-bend compression, adding rigidity to the mast section. This negates the need for a baby stay or inner forestay.
- Runners and backstay are not usually fitted as the spreader sweep angle allows the cap shrouds to provide the necessary longitudinal support.
- Inner forestays and baby stays are never used.
- Sometimes fitted with fixed struts which stay the lower part of the mast.

The absence of a backstay reduces the mast compression on this type of rig in comparison with conventional rigs. This, along with any fixed struts, means that the mast profile is often relatively small both athwartships and fore-and-aft. Advocates of the B & R rig maintain that its “better aerodynamics” make it suitable for racing, and the leisure sailor benefits from avoiding trimming the rig while sailing. The lack of backstay and runners means that there are no adjustments to be made at sea. The foredeck is free from baby stay and inner forestay, and this makes tacking easier. Most of the trimming of the rig must be done before the mast is stepped on the boat.

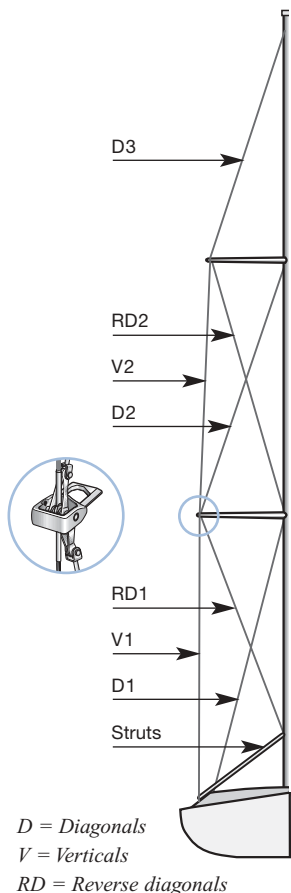

At the crane

- Lay the mast on two trestles. The sail track must face downwards. The trestles must be high enough to keep the spreader ends off the ground. All stays must be loose.
- Tighten the reverse diagonals to give the mast a positive pre-bend. Begin with RD1, then RD2. These shrouds interact, and, to provide an even curve, they must be tensioned by about the same amount.

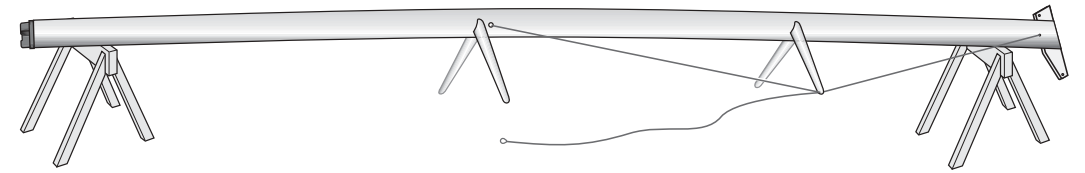

- The amount of a pre-bend depends on the cut of the mainsail. A general rule is that the pre-bend should be 1% of the distance from the masthead to the gooseneck, measured at the centre of this distance. The mast must have no lateral bend. All pre-bend must be in the fore-and-aft direction.

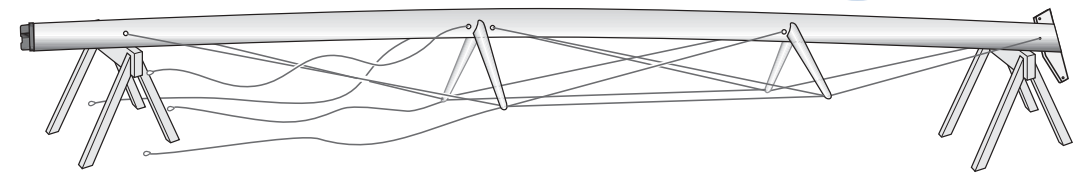
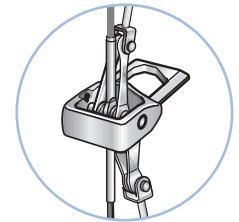

- Position the lifting stop between the spreader brackets, just above the point of balance, and hold down with a strong line. Make sure the forestay is not inside the stop. It is usually possible to make the eye long enough to enable it to be cast off without going up to the lower spreaders on a double spreader rig.
- Raise the mast, and place it on the T-base.
- Attach the cap shrouds but do not tighten them yet.
- Attach the forestay.
- Attach the lower shrouds.
- Hand-tighten the cap shrouds and forestay.
- Set the fore-and-aft mast rake by using the main halyard as a plumb line. Attach a weight to the halyard. The mast is normally either vertical or has a slight aft rake. The mast rake can be altered by adjusting the length of the forestay using the rigging screw or using toggles.
- Tension the forestay rigging screw, but not too much.
- Tension the cap shrouds to 20% of their breaking load. See the folding rule method, page 29. The pre-bend will now increase slightly.
- Lower and remove the lifting stop. Move the yacht away from the crane.

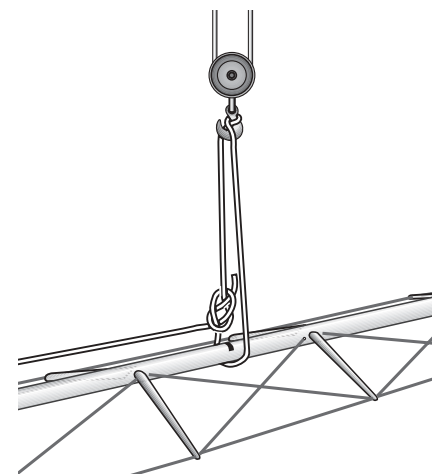

Continued...

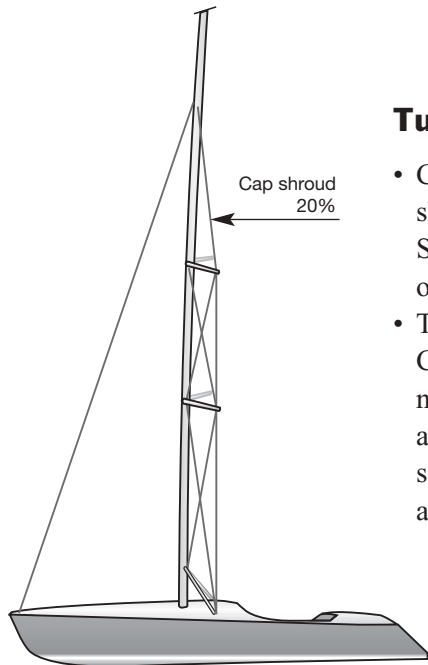

Tuning

- Check that the upper part of the mast is straight athwartships. Adjust if necessary using the intermediate shrouds. Slacken one side by the same amount you tighten on the other.
- Tension the lower shrouds to 20% of their breaking load. Check that the mast is straight athwartships. Adjust if necessary using the lower shrouds on the same principle as above. The mast should now have approximately the same pre-bend as it had when it was lying on the trestles, and it will be straight athwartships.

Tuning under sail

- Sail the boat at about a 20° angle of heel. The lee cap shroud and lower shroud must not be slack. If they do slacken, they must be tensioned so that the slack is halved. Then tack the boat and tighten the equivalent amount on the other shrouds, which are now on the lee side.
- Check that the mast is straight athwartships by sighting up the mast from deck level. Tension both sides by the same amount so that the mast is straight on both tacks.

When you have trimmed a B & R rig, you must document the setting of the rigging screws very carefully. Alternatively, store the mast for the winter with the spreaders mounted and the intermediate shrouds and reverse diagonals in tune.

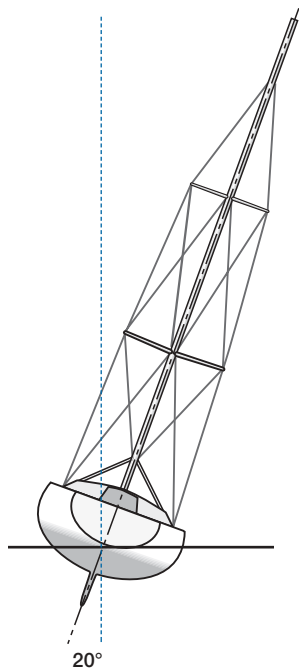

Booms

Seldén's booms are fitted with slab-reefing or single-line reefing, or are adapted for use with in-mast furling. The boom profiles are relatively deep in relation to their width. This gives a boom which is light in weight, and has a high resistance to vertical bending.

The booms are fitted with stoppers at the gooseneck, if sail-handling is to be done forward at the mast. No stoppers are fitted if the lines are to be led back to the cockpit.

For detailed information, please order our spare parts list, art no 595-081-E.

Slab-reefing boom

Fitted with 1-4 reefs and outhaul.

Reefing

1. Ease the sheet and vang, then set up the topping lift.
2. Ease the main halyard by just a little more than the height of the reef.
3. Hook the luff cringle for the reef in one of the two reef hooks at the gooseneck.
4. Tighten the halyard.
5. Reef the leech by hauling in the reefing line using the reefing winch.
6. Ease the topping lift, tighten the vang and haul in the sheet.

To shake out a reef

1. Ease the sheet and vang, then set up the topping lift.
2. Release the reefing line
3. Ease the halyard slightly, unhook the luff cringle.
4. Tighten the main halyard.
5. Ease the topping lift, tighten the vang and haul in the sheet.

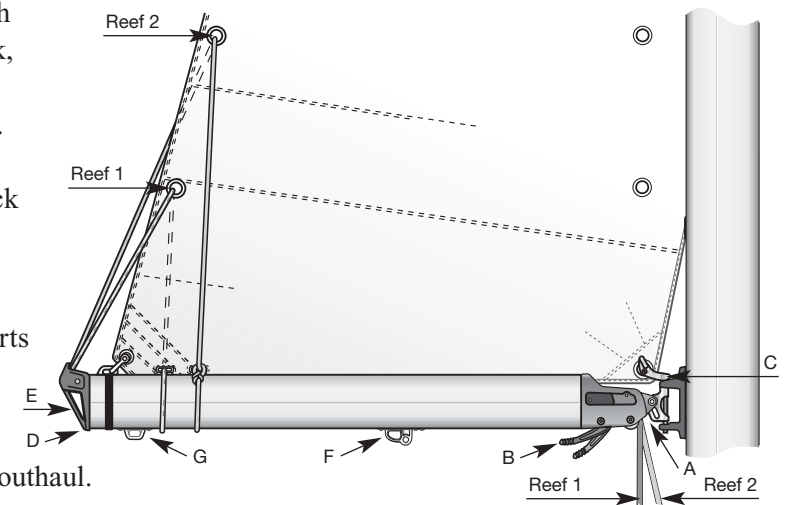



- A. Gooseneck including sheaves for reef-lines and outhaul.
- B. Spring-loaded rope clutches, colour code equivalent to rope.
Reef 1: Blue
Reef 2: Red
Reef 3: Yellow
Reef 4: White
Outhaul: White
- C. Reef hooks for slab-reefing.
- D. Boom end, fitted with screws. Easy access for maintenance and line replacement.
- E. Cast bracket for preventer guy.
- F. Kicker slider.
- G. Main sheet slider.

Continued...

Single-line reefing

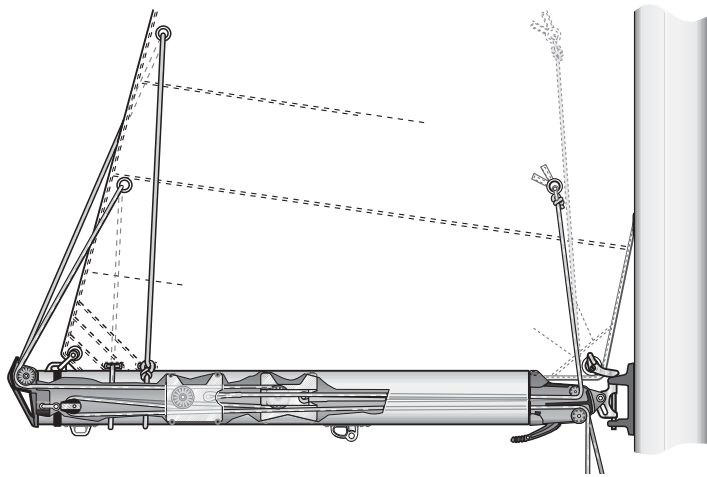
Fitted with two Single-line reefs and outhaul. A flattening reef is available on request. Through a system of blocks inside the boom, a single line pulls both luff and leech down to the boom. The block system has a 2:1 purchase. If the halyard and reefing line are led back to the cockpit, there is no need to go on deck to take a reef. Make two permanent markings on the halyard at the position for reef 1 and reef 2.



 It is important to note that no fittings should be mounted on the sides of the booms. The space between the carriages for the running blocks and the sides of the boom is limited. Fastenings for external fittings could prevent the movement of the carriages.

We recommend that you use a rigid vang. This prevents the boom from falling into the cockpit when you are taking in a reef. Fitted with a gas spring, it replaces the topping lift, which can be removed.

Reefing

1. Ease the sheet and vang, then set up the topping lift.
2. Ease the main halyard to the first marking.
3. Haul in the reefing line so that both the luff and leech cringles are pulled down to the boom, and then take up the slack in the 2nd reef.
4. Tighten the vang and haul in the sheet.

To shake out a reef

1. Ease the sheet and vang.
2. Release the reefing lines.
3. Tighten the main halyard and then the sheet and vang.

In-mast furling (manual version)

The boom is fitted with an outhaul, and the mast with a line-driver winch which is operated by an endless furling line.



Reefing; we assume that the outhaul and furling line are led back to the cockpit, and that a rigid vang is fitted.

1. Tighten the vang slightly to maintain tension in the leech.
2. Slacken of the sheet.
3. Ease off the outhaul about 0.5 meter (more or less, depending on how deep a reef you want to take in) and apply the stopper.
4. Haul on the starboard part of the furling line until the outhaul is tight. Apply both stoppers.

To shake out a reef

1. Adjust the vang to apply a moderate tension in the leech of the sail.
2. Release the stoppers for the furling line to allow the sail to unfurl from inside the mast.
3. Tighten the outhaul.

There is a more detailed description in Seldén's operating instructions for in-mast furling.

Rodkicker

Rodkicker is Seldén's rigid vang. It replaces the topping lift by preventing the boom falling into the cockpit during reefing. In addition, when fitted with a gas-spring, it lifts the end of the boom, and this opens the leech of the main-sail. A very useful trimming aid, in other words.

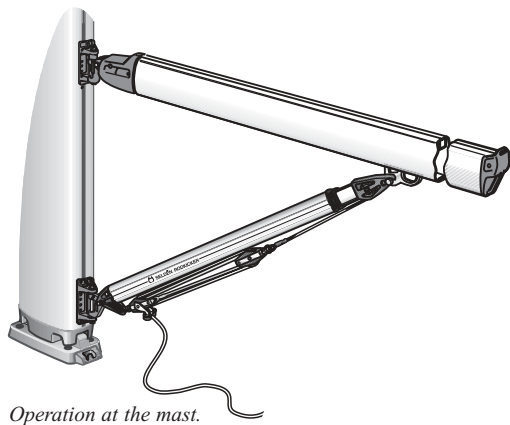

Operation at the mast.



Operation from cockpit.



Fitting a Rodkicker

Detailed fitting instructions are included with every Rodkicker, but two points are of particular importance.

1. Under no circumstances must the rigid vang be allowed to “bottom out” when the mainsail is sheeted fully. If it “bottoms” it generates a breaking force which can damage the boom.
2. Seldén's booms are fitted with a kicker slider as standard. This runs in a groove on the underside of the boom. The slider is not fixed, since its correct position depends on the cut of the mainsail. When the correct position is established, the kicker slider is located permanently with three bolts, so that it will not slide in the groove. This is done by drilling clearance holes (holes 2 mm larger than the diameter of the bolt) in the boom. The bolts are threaded in the kicker slider for the whole of their length. In this way the kicker fastening is fixed when the bolts go into the holes.



Working aloft

Three things are important when working aloft.

1. Using proper equipment.
2. Using the right technique.
3. Having skilled and reliable assistants.

1. Equipment

- Use a high quality, professionally made bosun's chair that fits comfortably round waist and legs.
- The pockets in a bosun's chair are often too shallow for practical use. Plastic buckets are not good for holding tools, as they easily tip over if they catch on an obstruction. It is best to keep tools in a canvas bag fastened to the chair with a short line.
- Take a short piece of rope with you, so that you can tie the bosun's chair to the mast when you reach the “work-place”.
- To increase safety a second halyard should be used, to be hauled in and eased off at the same time as the first.
- Check that the halyards you are about to use are in good condition and that splices and Talurite swages are in good order.

2. Technique

- Before going aloft, think carefully about the work you have to do and plan it, so that the time up the mast is kept as short as possible.
- To minimise swinging when going aloft use the “lowest” of the halyards that reach up to the workplace. The most important point, however, is to make sure that the halyard and splices are in good condition. One method of reducing swinging is to attach the bosun's chair to a snatch block running on a third halyard, which is kept tight.
- Attach the chair with a knot or a heavy duty screw shackle directly to the eye-splice of the halyard. **Never use a snap- or key shackle.**

Continued...

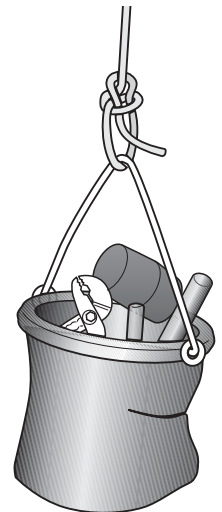
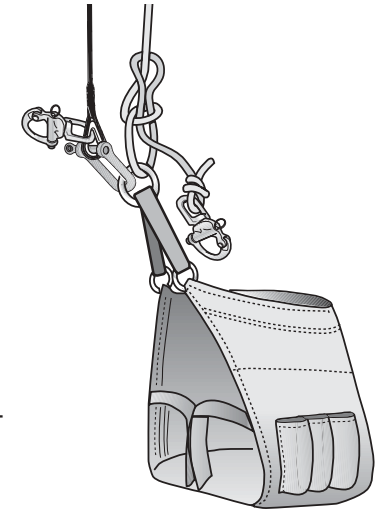

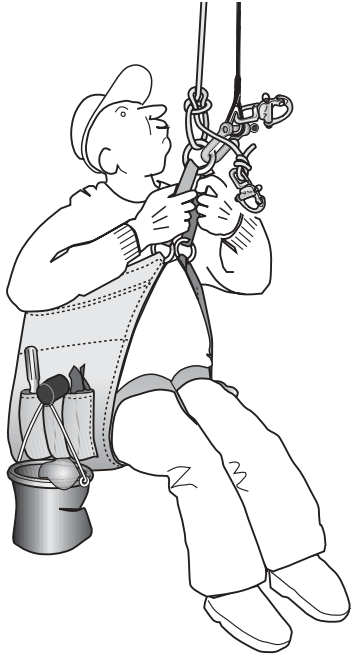

- If it is difficult to communicate, because of noise or darkness for instance, then a signal system must be agreed beforehand. Knocking on the mast with a tool can be easily heard. For example, the code could be: 3 taps for “up”, 2 taps for “down” and 1 tap for “stop”.
- It is very laborious and time-consuming to winch a person up the mast. The person going up the mast should help.
 1. Climb up the mast using the same technique as when climbing a rope.
 2. “Walk” up the mast, holding on the halyard and the stays.
 3. When the boat is heeled over it may be easier to walk up the leeward shroud or on the mainsail.
- When you reach the “workplace”, fasten yourself to the mast or rigging in such a way that you can move within a circle of about an arm’s length.
- During longer periods of work, a further safety measure is to fix the bosun’s chair to a strong point, in order to relieve the load on the halyard.
- Work as efficiently as possible, but do not neglect safety and thoroughness. Do not drop anything – remember that a tool dropped from the masthead can punch a hole in the deck or injure a crew member.
- On the way down make sure that you do not snag any of the fittings or other projections.

3. Assistants

- Lead the halyard round a winch with the smallest possible number of turns, so as to avoid override. If possible, use a winch fixed some distance from the mast – to avoid the risk of being hit by dropped tools. This also makes it easier for the assistant to look up the mast.
- The second security halyard must be operated over a separate winch and by a second assistant.
- The halyards must be cleated when the person aloft is in position, even if a self-tailing winch is used.
- When a person is being winched up the mast while under sail, the winching should be temporarily stopped, if the boat sails into a particularly heavy sea.
- Before lowering the person, the line should be checked to ensure that it is free from kinks. Lower at a steady speed and not too slowly.

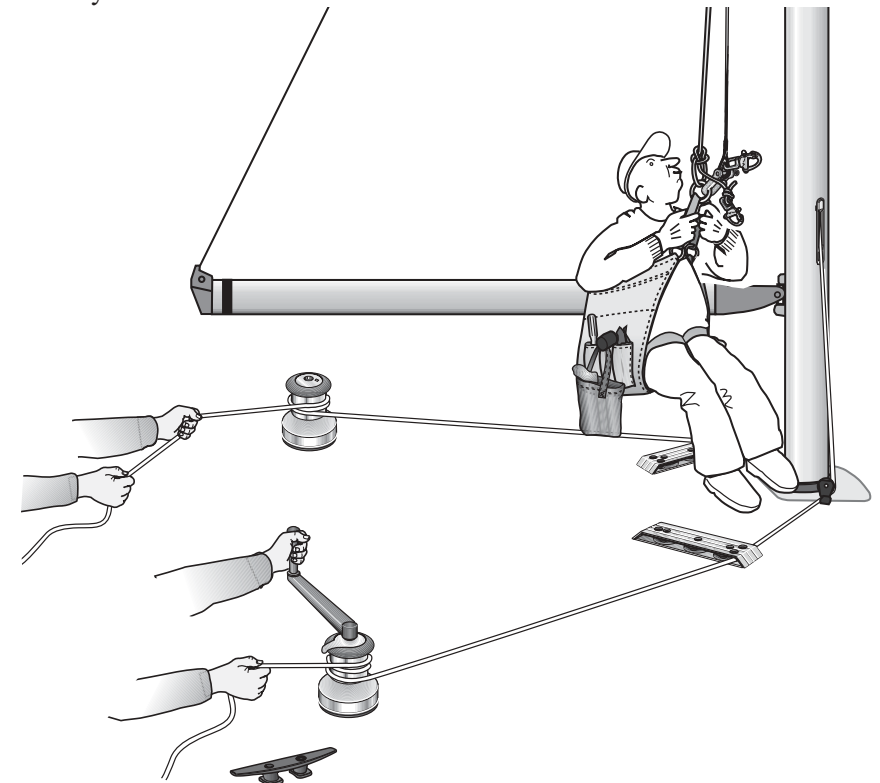

Unstepping the mast

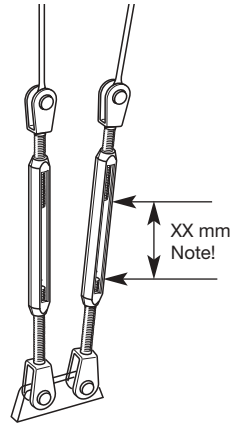

Preparations

- Remove the sails and store in dry conditions during the winter. Consider whether you need repairs by a sail-maker.
- Remove any removable parts, such as the spinnaker pole, boom, rigid vang and any appropriate running rigging, including the spinnaker downhaul and main sheet. Secure the end of the boom with the main halyard or topping lift to prevent the boom falling into the cockpit when unfastening the rigid vang. Unreeve the jib furling system's control line from the fairleads.
- Climb the mast and remove any sensitive equipment if you think that it may be damaged at the crane.
- Make sure the positions of the rigging screws are documented to make it easier to trim the rig in the spring. If not, write down the distance between the ends of the two screws on each rigging screw. Enter your figures on page 80.

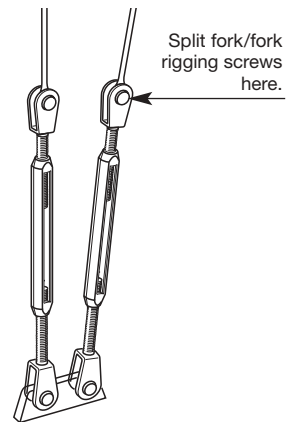

At the crane

- Read the "At the crane" section on pages 20-21.
- Follow the instructions for your rig type, but in reverse.
- Disconnect the rigging screw from the stay/shroud in the upper part of the rigging screw. This prevents the rigging screws dragging along the ground when the mast is taken down. Re-attach the clevis pins and split pins to the rigging screws to avoid losing them. If the upper part of the rigging screw is a threaded terminal (stud terminal) swaged to the wire, disconnect the rigging screw at deck level.

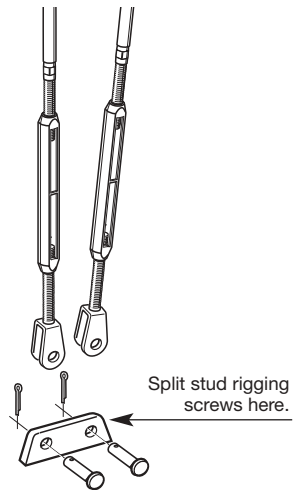

Winter maintenance

- Place the mast on trestles.

Standing rigging

- Wipe over the standing rigging with a cloth and solvent.
- Check stays and shrouds for fraying. If one or more wire strands have failed, the stay or shroud must be replaced by a new one. In this event, change a "complete pair", i.e. both cap shrouds, both aft lower shrouds etc. The complete pair should be changed even if only one of the wires is damaged. The opposite wire will have been subject to the same stresses.

Standing rigging which remains in contact with the mast throughout the winter may cause corrosion damage to the mast due to galvanic reaction between steel and aluminium. The risk of this happening is high in humid and salty atmospheres.

- Disconnect the spreaders and all standing rigging. Remove the spreader ends from the spreaders. Check for failed wire strands in the area where the spreader end is connected to the shroud. To simplify re-rigging the spreader ends can be left on the shrouds. For linked rigging, there is normally no need to alter the setting of the rigging screws connected to the spreader ends.
- Coil and store the entire standing rigging separately.
- Detach any jib furling systems and remove parts such as line guide, drum and halyard swivel.
- Clean the rigging screw threads using a solvent. Lubricate with Seldén rigging screw oil.

Continued...



All rigging screws should be lubricated every year. Art. No. 312-502.

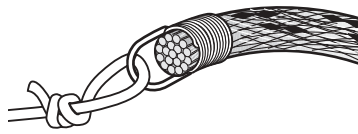

Whipping with messenger eye.

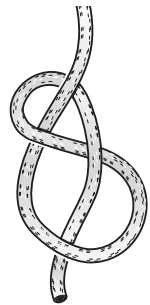

Stopper-knot (figure-of-eight).

Get into the habit of ordering replacement parts in the autumn. This makes it easier for yourself as well as our dealers.

Running rigging

- Remove the running rigging from the mast and replace with thin messenger lines. The messenger line should be carefully tied to the end of a halyard. When the halyard is pulled out of the mast, the messenger line is pulled in. Removal of running rigging eliminates any risk of theft, and allows it to be washed.
- Check the running rigging for unusual wear on cordage, whippings and splices, and for any failed strands of wire. If you should find any worn parts, ensure that you find out what caused it and repair the fault.
- If the running rigging is left on the mast, any wire parts on the halyards should be pulled out of the mast, coiled and prevented from coming into contact with aluminium to prevent galvanic corrosion. Tie a stopper-knot at the free end of the halyard.
- Examine the shackles, particularly any quick-release shackles, for cracks and deformation. Also ensure that they close properly.

Mast and boom

Anodized sections

- Rinse the mast, boom, spinnaker pole, rigid vang and jib furling system with water. Where possible, rinse the inside as well.
- Wash with a mild detergent solution, such as dishwashing liquid. Rinse carefully, since most detergents contain substances which may corrode aluminium. Let the components dry. Careful cleaning is particularly important at the foot of the mast, where the mast is most exposed to salt.

- Carefully check all structural fittings for:

- Cracks
- Deformation
- Wear/play
- Fastening
- Corrosion
- Ageing (plastic)

- Check any leads for the genoa halyard. The halyard for a jib furling system is sometimes led through a bronze fitting (halyard lead). If a wire halyard is used, the bronze fitting will wear, rather than the halyard. Replace the halyard lead if you don't think it will last another season. For more information on this, please see the instructions for Furlex jib furling and reefing system.
- The boom outboard end-fitting is attached with screws. To ensure that these can be removed, the threads should be greased every season. Remove and grease one screw at a time.
- Check that moving parts (sheaves, locking arms on the gooseneck etc.) are not stuck.
- Coat all aluminium sections on the rig in paraffin oil, yacht polish or wax. This seals the pores of the sections and preserves surface shine. Cast metal parts also benefit from this treatment. On Seldén masts, all cast metal fittings are, however, lacquered and therefore permanently protected.

Continued...

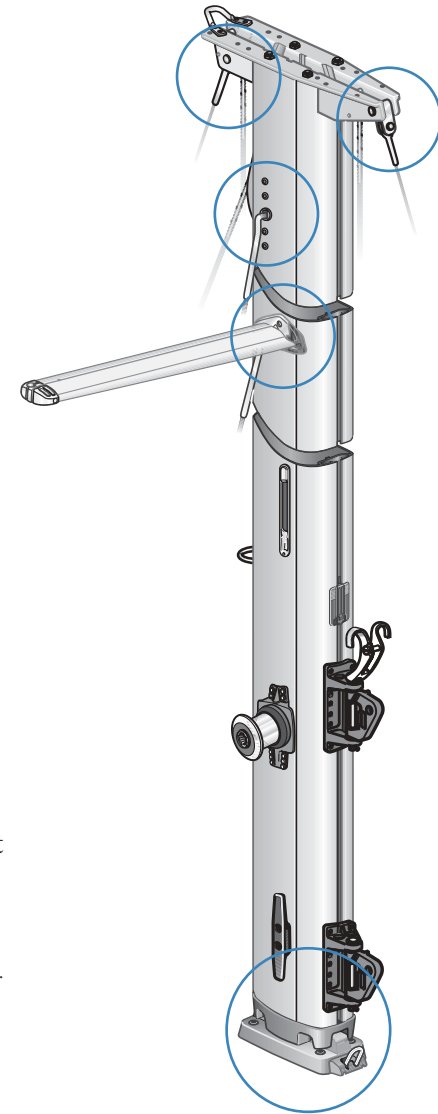

Check all structural parts.

Painted sections

- ! • The maintenance of a painted mast/boom is the same as for anodized equipment. It is, however, important to check, and rectify, any damage which has penetrated the paint. The aluminium section has no protective anodized surface underneath the paint.
- Seldén use powder coatings in their painting process. For touch-up work, you will have to use wet paint. Use a paint which is suitable for use on aluminium, select the correct shade and follow the manufacturer's instructions.
- Seldén warranty will not cover corrosion on the mast/boom or blistering of the paint associated with any of the items on the list below.
 1. Damage to the paint.
 2. Fittings mounted to the mast after delivery from Seldén.
 3. Holes that are drilled in the mast after delivery from Seldén.

If you wish to cut/drill into the painted mast, please follow the advice below:

- Water and air must not be allowed to get to an exposed edge of the painted mast section. If it does, there is a high probability that, in time, corrosion will spread under the paint causing unsightly blistering.
- To achieve this protection, it is recommended that fittings are bedded down onto the mast with "Mastic Frame Sealant". If there is an exposed edge, this must be carefully protected with a chromate primer and top-coat.

Damage or cosmetic flaws?

Learn to distinguish between what is to be regarded as damage, and rectified, and what can be regarded as a cosmetic flaw. Try to trace the reason for any imperfection and take necessary measures to avoid it for the future.

Examples of damage

- **Dent in mast or boom extrusion.** Describe the depth, area and location of the dent to your Seldén dealer. We can then suggest what needs to be done.
- **A permanent bend in the mast extrusion.** If the bend cannot be corrected by rigging adjustments, this is a serious damage. Make contact with Seldén for rebuild with new extrusion, or alternatively, a new mast.
- **Corrosion damage to stainless parts,** that is corrosion which has gone deep and which cannot be removed by polishing. The part must be replaced.
- **Loose fittings.** Refit with the correct pop-rivets or screws.
- **Broken strands.** Replace the wire. Also replace the corresponding shroud on the "other side", if the lateral rigging is involved.
- **Any damage to carbon products** must be inspected and repaired by a specialist as soon as possible. Carbon is a strong lightweight material, but less tolerant to impact damage than aluminium, so it must be handled with due care. For example, if a carbon spinnaker pole tube is exposed to point loading, a crack can develop. This will weaken the tube, and eventually lead to failure.

Continued...



Examples of cosmetic flaws

- **Scratches and chafing on anodized surfaces** such as mast and boom extrusions. Damage to an anodized layer is self-healing, through the material oxidizing. The oxide forms a protective surface over the damage. Polishing and subsequent waxing will also help protect the exposed surface.
- **Brown discoloration** can occur on all stainless material, and can be removed by polishing.
- **Discoloration of carbon products.** The products are UV protected but with time the resin surface of the carbon products may discolour and lose the gloss finish. This is normal and has no effect on the performance of the product.

Storage

- The mast, boom and jib furling system should be stored in airy conditions throughout the winter. Luff groves are placed downwards to prevent water accumulating which may result in frost damage. This is particularly important for the jib furling system. The equipment must never be wrapped in plastic or other material, as this will prevent air circulating.
- Avoid storing a painted mast or boom on arms protected with material which can hold water. The moisture will cause blisters in the paint. Carpet and soft woods are worst. Nylon and hard woods are best.
- Using the mast as a ridgepole for a tarpaulin may be practical, but make sure it is well protected from chafe. The anodized layer is only 20 microns (0.020 millimetres) thick and can be worn off by a tarpaulin rubbing against the surface, resulting in permanent imperfections.
- Carbon products are, as mentioned above, sensitive to point loading and must be handled with care.

Bear in mind when mounting new fittings

- To minimise the risk of corrosion, insulation must be placed between the fittings and the mast section if these are of dissimilar metals. Use a zinc chromate primer or similar. You can also use a spacer, e.g. a nylon disc (included with Seldén fittings). The risk of corrosion is particularly high when marine grade steel fittings are attached to aluminium. The corrosion risk increases with the size of the contact surface. Fittings made from brass or other copper-based alloys should never be fitted in such a way that they come into contact with aluminium.
- Bearing in mind the risk of corrosion, monel pop rivets are the best choice for fastenings, particularly when attaching something to a thin-walled (< 3 mm) section. The pop rivet body should extend inside the section by 1.0-1.5 x diameter. The pop rivet mandrel should always be punched out as these are made out of carbon steel and may discolour the mast when they rust.
- If machine screws are used, they should be insulated with locking adhesive, waterproof grease or anti-corrosive paste.
- Specialist knowledge and tools are required for any modification to carbon products.

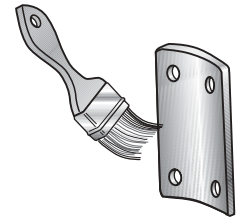

All stainless fittings mounted by Seldén are lacquered for insulation.



Waterproof grease.



Locking adhesive.

Masts which are seldom unstepped



Remove any instrument base and the sheave separator. Lift out the sheaves for inspection. Replace the sheaves if necessary, and refit the separator.

Regular inspection of the rig is obviously essential even if the mast is not unstepped in the autumn. On a stepped mast, the work has to be done from a bosun's chair. Follow the "Winter maintenance" instructions, and check all structural and moving parts.

Seldén masts from 2003* and onwards are equipped with a masthead fitting which makes it easy to check and replace halyard sheaves. There is no need to lower the mast to remove the sheaves.

The larger sections (F324-F370; E321-E365) feature a similar design.

*Section C211-C304; F212-F305

Boat ashore with the rig still in place

- Decrease the tension of your lateral rigging slightly just to ease off the load on the hull. No part of the standing rigging should be slack. Slack rigging will create substantial wear during the winter.
- Make sure your cradle is strong enough for the loads created by the windage of the rig.
- Do not forget to do the winter maintenance of your rig!

Some thoughts on calculating mast and rig dimensions

Righting/heeling moments

A rigging calculation is based largely on the yacht's righting moment, i.e. the yacht's resistance to the heeling force of the wind.

The greater the yacht's resistance, the greater the forces generated in the rig. A large sail area in a light wind has the same effect as a small sail area in a strong wind as far as heeling moment is concerned.

The righting moment, often abbreviated to "RM", is largely determined by the yacht's displacement, keel weight, beam and draft.

Shrouds and stays

The forces affecting the shrouds are calculated using the principle that the shroud must be able to withstand the heeling force of the wind and the yacht's RM. The maximum actual force is multiplied by a safety factor, and this gives the required breaking load for every shroud. Suitable dimensions of wire or rod are then selected to meet the breaking load conditions.

The safety factor is chosen so that the shrouds, in addition to having a sufficient breaking load, will have good fatigue strength (=service life) and low stretch under load.

The forces in the longitudinal rigging and the running rigging are based on values gained from experience. The forces involved are usually closely related to the yacht's righting moment, even though they are generated by the crew trimming the rig.

Continued...

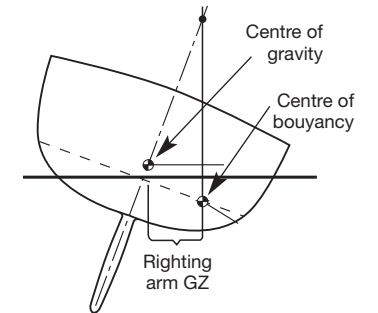

Righting moment = $GZ \times \text{displacement}$.

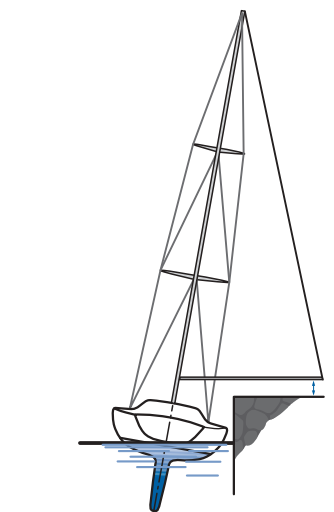
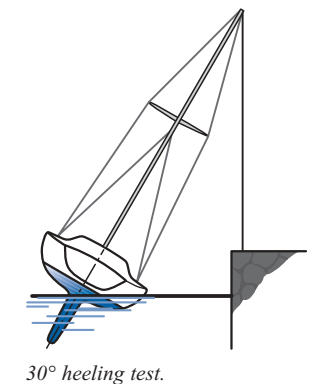

5° heeling test for larger yacht.

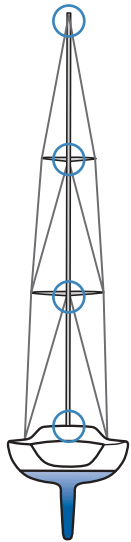

Mast

The mast compression is calculated first. The factors involved are:

1. Forces in the lateral rigging (the shrouds) primarily related to the yacht's RM, and chain plate beam.
2. Forces in the longitudinal rigging.
3. Forces in the running rigging.

The dimensions of the mast extrusion are determined by:

1. The mast compression.
2. The height above deck of the forestay.
3. The location of the mast foot (on deck or on the keel).
4. The number of pairs of spreaders.

It is the distance between "staying points" which, along with mast compression, determines the dimensions of the mast extrusion. Staying points are at deck level, the spreader fittings and the cap shroud fitting.

The longitudinal stability of the mast must be calculated separately. Staying points in this direction are the fastenings of forestay, backstay, double lower shrouds, baby stay, inner forestay, cutter stay/runners, check stays and spreader brackets for swept spreaders.

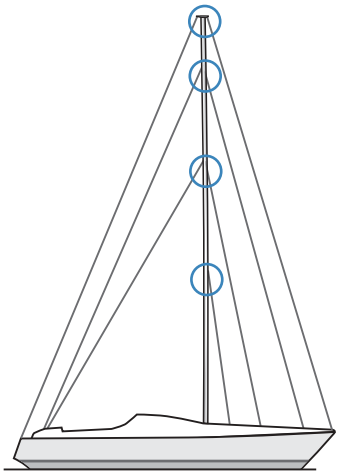

Staying points.

Boom

The strength required from the boom depends on the force from the vang, also closely related to the RM, the force from the mainsheet and the length of the boom. The location of the sheeting point is also very important (boom-end sheeting or centre-sheeting).

Jib furling system

The jib furling system is exposed both to vertical forces (halyard loads), and to torsion (twisting forces) in the extrusion. Both are determined by the crew. Torsion arises when sailing with a partly rolled sail. Sheet load related to the yacht's RM determines how great the torsion becomes, and is therefore critical for dimensioning. We also take into account the yacht's rig type. A masthead rigged yacht has relatively larger loads in the foresail than a fractionally rigged yacht. That is why our versions of the Furlex jib furling system have different "RM-limits", depending on rig type.

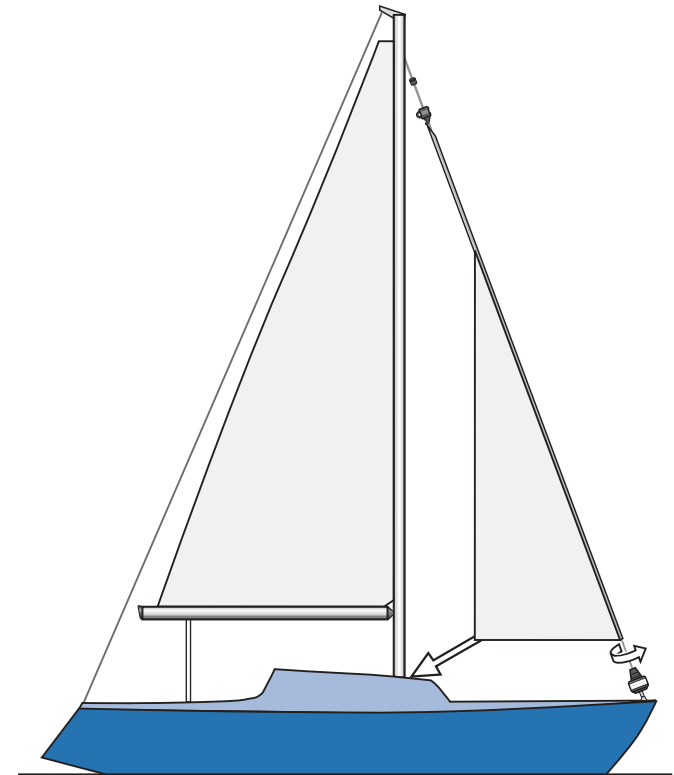

Positive roach + in-mast furling



Seldén in-mast furling system: Geared line driver winch, tensioned luff extrusion, asymmetrical located sail slot and the patented load distributor of the halyard swivel. All to make furling an easy and fast operation.



Seldén patented load distributor.



Extra wide sail slot for vertical battens.



Anyone who imagines that a furling sail is less efficient because it cannot provide sufficient roach would be wrong. The new Seldén in-mast furling masts are made for vertical battens and a true positive roach.

Sail slides and sail entry

MDS full batten system

Seldén MDS-cars (Multi Directional Support) are supported in all directions, making sail handling simpler. A full batten always creates a side load on the cars, particularly when you release the halyard for taking a reef. The side load absorbing wheels of the car run along guide flanges in the mast groove, allowing simple and low friction mainsail handling. The sail entry is removed when installing or removing the cars.



Guide flange
Side-load absorbing wheel

Sail slides

For sails with conventional slides, use the spring-loaded mid section of the sail entry.

Luff-rope
Sail feed and groove insert for traditional luff-rope is available. Talk to our dealers for more information.

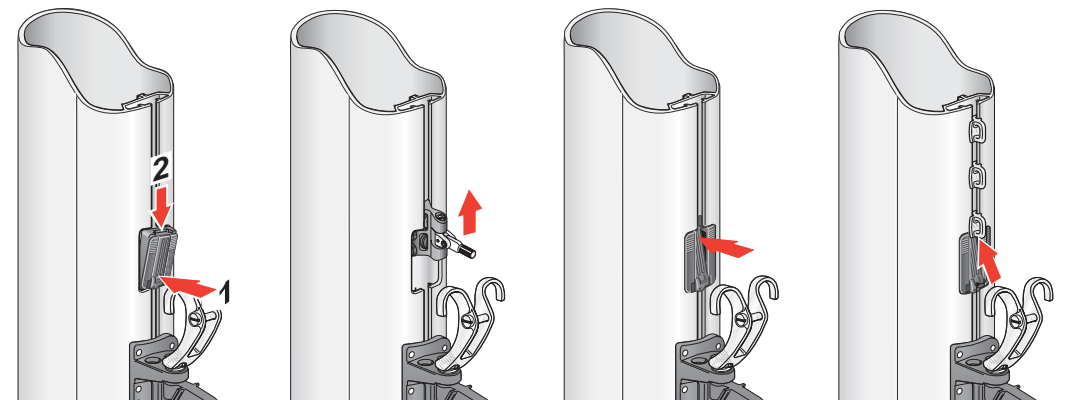

Remove sail entry to install MDS cars.

- 1 Push in
- 2 Push down

Spring-loaded mid section for conventional slides.

The Seldén product range



Foresail and mainsail furling and reefing systems

Furlex

Furlex is the best selling jib furler in the world. It gives you full control over the foresail in any weather. We use our own technical solutions to reduce resistance, friction and bearing loads.

The unique bearing in the halyard swivel was developed for Furlex but is now available as standard in all Seldén furling gears.

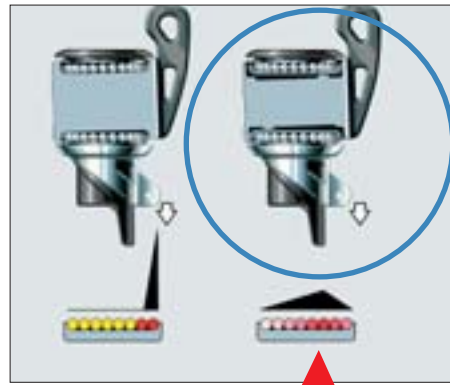

Seldén patented load distributor.



Furlex comes in five sizes, 100S, 200S, 300S, 400S and 500S, and is suitable for yachts ranging from 25 to 70 feet.

Furlex Hydraulic

With a Furlex Hydraulic on board, you will find sail handling even simpler. All you need to do is press a button in the cockpit! The Furlex Hydraulic is designed to provide a harmonious visual interplay of stainless steel and aluminium. The hydraulic motor is located inside the worm gear, as on the in-mast furling system. The positioning of the motor contributes to the compact design of the Furlex Hydraulic.



Furlex Hydraulic is suitable for yachts ranging from 35 to 70 feet.

Hydraulic clew outhaul

If your yacht is equipped with a Seldén in-mast furling and reefing system, you can discard the manual outhaul winch, and have your boom converted to full “push button” hydraulic outhaul operation.





Seldén spinnaker poles

Four strong characters in aluminium

Seldén aluminium spinnaker poles give you fast and safe spinnaker handling. All the fittings have well-rounded edges and corners, to prevent damage to your hands and equipment. The spinnaker pole range contains four variants:

- Type A, the tried and tested end-for-end gybing pole with front opening.
- Type B for dip pole gybing or twin pole arrangement.
- Jockey pole reduces the loads and minimises the wear on guys and life lines. A necessary aid for efficient spinnaker sailing with improved sheeting angle.
- Telescopic pole, can be extended to 1.25 and 1.5 x standard spinnaker position, a must when poling out a large genoa. The telescopic pole is also perfect for poling out a cruising chute. And it can be telescoped down 20% for easier storage.



Type A, end-for-end pole.



Type B for dip pole gybing.



Jockey pole.



Telescopic pole.

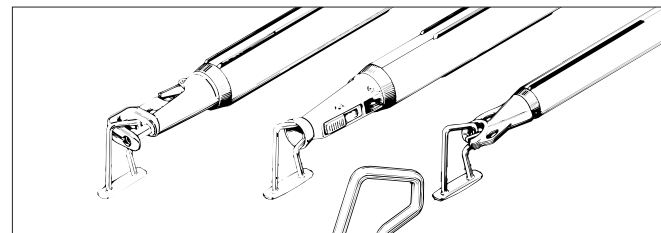

Seldén has a range of brackets for deck and vertical stowage.

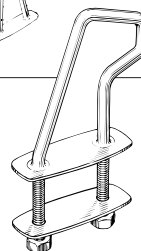

Carbon, the dark range that lightens up life onboard

Seldén carbon spinnaker poles are designed to make light work of spinnaker handling. The big advantage of carbon fibre is of course its low weight. The weight saving means that the crew can handle the spinnaker faster, with less effort. It's safe and it's convenient.

In all sizes

Seldén carbon spinnaker poles are suitable for boats from 2 to 30 tonnes. The poles are supplied finished to length, fully complete. They can be equipped with all types of Seldén end fittings. Smaller poles can also be equipped with composite fittings.





Single Line Reef.

Booms with a strong profile

Seldén booms can be fitted for traditional slab reefing, Single Line Reef, or in-mast furling systems. The boom extrusions are relatively deep in relation to their width, allowing a lighter extrusion with high resistance to vertical bending. This makes them perfect for use with modern, stiff sailcloth and efficient rigid vang.



Seldén Rodkicker rigid vang, a real kick

A Rodkicker makes reefing easier and prevents the boom from dropping into the cockpit or onto the coachroof. Seldén Rodkickers are available in three sizes for boats up to 25 tonnes. A Rodkicker with an internal gas spring lifts the boom automatically when the kicking strap is released. It replaces the topping lift, making reefing and trimming fast and simple.



Seldén rig fitting

Backstay tensioners

Seldéns' backstay tensioners are easy to operate, they have smooth, clean surfaces. Even the wire terminal is fully covered.

Rigging screw covers

The rigging screw cover is smoothly rounded and gentle on your sails, sheets and clothes. Nothing can get snagged on the rigging screw or chafe against the shroud.

Rigging screws

The Seldén range includes a series of rigging screws made from stainless steel or combination of stainless steel and chromed bronze.

Rigloc, a unique, practical locking device. Found only on Seldén chromed bronze rigging screws.



Fast access to our know-how, worldwide



The Seldén Group is the world's leading manufacturer of masts and rigging systems for dinghies, performance dayboats and yachts up to 30 tonnes. Our well known brands are Seldén, Furllex and Proctor.

Seldén has built a network of authorised service centers covering the world's marine markets. So wherever you sail, you can be sure of fast access to our service, spare parts and know-how.

Please visit our web site and find your nearest Seldén service center along with the entire library of useful instructions.

Seldén Mast AB, Sweden

Tel +46 (0)31 69 69 00

Fax +46 (0)31 29 71 37

e-mail info@seldenmast.com

Seldén Mast Limited, UK

Tel +44 (0)1489 48 40 00

Fax +44 (0)1489 48 74 87

e-mail info@seldenmast.co.uk

Seldén Mast Inc., USA

Tel +1 843-760-6278

Fax +1 843-760-1220

e-mail info@seldenus.com

Seldén Mast A/S, DK

Tel +45 39 18 44 00

Fax +45 39 27 17 00

e-mail info@seldenmast.dk

Seldén Mid Europe B.V., NL

Tel +31 (0) 111-698 120

Fax +31 (0) 111-698 130

e-mail info@seldenmast.nl



www.seldenmast.com