

# Furlex E/TDE

(Electric)

Furlex has been making life on board easier for decades. In fact, Furlex is the best-selling headsail furler in the world. Once you have experienced using a Furlex you will not want anything else up front. And now there is a new Furlex that will make life on board even easier. Lean back and enjoy Furlex Electric.

## All the power you need

The new Furlex Electric is available as a complete kit or as an upgrade kit for an existing Furlex 200S, 300S or 400S series. The push-button performance of a Furlex Electric makes pulling on the furling line a thing of the past.

## Reliable action

Furlex Electric is designed around a highly efficient 12V or 24V electric motor. Power is transmitted to a self-locking worm gear to rotate the luff extrusion at a max torque of 60Nm (200E), 90Nm (300E) and 135 Nm (400E) respectively. These high torque levels mean that you can always rely on being able to furl your foresail – even when the wind and sea are doing their worst. The motor uses only 30 amps at normal load and it takes 25-30 seconds to furl a genoa. Once the required sail area is set, the worm drive provides a mechanical lock.

In order to prevent accidental overloading, the system comes with a built-in circuit breaker. If you attempt to reef the sail without first releasing the sheet, the power is immediately switched off. This safety feature is automatically re-set a few seconds after the control switch is released. In the event of power failure, the sail is simple to reef manually. An emergency line-driver system is included as standard and can be used for both on-deck and through-deck installations. An emergency handle with 1/2" socket is available as an option.

Like all other Furlex models, Furlex Electric is equipped with Seldén's unique load distributor in the halyard swivel for low friction. Low friction means low power consumption and long service life.



## On-deck or through-deck. The choice is yours

Furlex Electric is available for either on-deck or through-deck installations. The main advantage of a through-deck installation is better sailing performance as a result of maximised luff length. More space on the foredeck is an added bonus!



*Installation of a Furlex 200TDE.  
The connection box is water-tight.*

## Upgrade your manual Furlex

Push-button performance is an easy upgrade for anyone who already has a manual Furlex 200S, 300S or 400S series on their yacht. The furling line, drum and line guard assembly are simply replaced with a Furlex Electric motor unit. No sail conversion is required as the luff length of your existing sail is unaffected.



Manual Furlex 200S.



Remove line guard, line guide, rope and drum halves.



Ready to get powered up.



Slide on Furlex 200E from below and install the cables. Done!



Heavy-duty toggle to withstand torsional loads. An extension link is available to provide anchor clearance.

*In case of power failure, Furlex Electric can be operated manually.*



*Manufactured from high-grade materials for rugged reliability and long service life.*



*Adjustment screws enable the Furlex housing to be aligned precisely.*



## Furlex Electric specifications

Type	Forestay diameter mm	L mm	H3 mm	HW mm	W2 mm	D2 diam. mm	H2 mm
200E	6	225	60	160	12	10	45
	7				14	12	
	8				14	14	
300E	8	260	80	210	14	14	65
	10				16	16	
400E	12	314	159	218	21	20	135
	14				23	22.5	

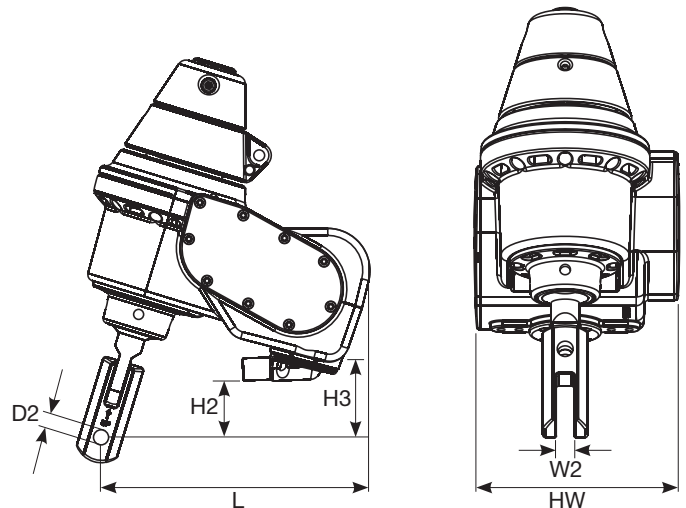

Type	Forestay diameter mm	Max. forestay length, m	Furlex Electric assemblies (excl. control pack)						Control pack*	
			Standard version Art. No.		Incl. rigging screw Art. No.		TDE version (Through-Deck) Art. No.		Art. No.	
			12V	24V	12V	24V	12V	24V	12V	24V
200E	6	10.6	031-021-11	–	031-021-21	–	031-021-31	–	532-448-01	–
	6	13.0	031-021-12		031-021-22		031-021-32			
	6	15.4	031-021-13		031-021-23		031-021-33			
	7	13.0	031-021-14		031-021-24		031-021-34			
	7	15.4	031-021-15		031-021-25		031-021-35			
	7	17.8	031-021-16		031-021-26		031-021-36			
	8	15.4	031-021-17		031-021-27		031-021-37			
	8	17.8	031-021-18		031-021-28		031-021-38			
300E	8	15.5	039-027-11	039-027-16	039-027-21	039-027-26	039-027-31	039-027-36	532-449-01	532-459-01
	8	17.9	039-027-12	039-027-17	039-027-22	039-027-27	039-027-32	039-027-37		
	10	15.5	039-027-13	039-027-18	039-027-23	039-027-28	039-027-33	039-027-38		
	10	17.9	039-027-14	039-027-19	039-027-24	039-027-29	039-027-34	039-027-39		
	10	20.3	039-027-15	039-027-20	039-027-25	039-027-30	039-027-35	039-027-40		
400E	12	17.7	049-034-11	049-034-16	049-034-21	049-034-26	049-034-31	049-034-36	532-468-01	532-469-01
	12	20.1	049-034-12	049-034-17	049-034-22	049-034-27	049-034-32	049-034-37		
	12	22.5	049-034-13	049-034-18	049-034-23	049-034-28	049-034-33	049-034-38		
	14	20.1	049-034-14	049-034-19	049-034-24	049-034-29	049-034-34	049-034-39		
	14	22.5	049-034-15	049-034-20	049-034-25	049-034-30	049-034-35	049-034-40		

### Cables & fuses included:

Furlex → connection box. Control box → switches. Control box → control panel.  
Fuse for control circuit in control box.

### Cables & fuses not included:

Connection box → control box. Control box → battery. Fuse for power supply.

\* Includes deck gland, control box, connection box, instructions and switches.  
Control pack is ordered separately, often prior to the delivery of the Furlex Electric assembly.

Type	Forestay diameter mm	Retro-fit installation kit incl. control pack			
		Type S → E Art. No.		Type TD → TDE Art. No.	
		12V	24V	12V	24V
200E	6	539-620-11	–	539-620-51	–
	7	539-620-13			
	8	539-620-15			
300E	8	539-638-11	539-638-21	539-638-51	539-638-61
	10	539-638-13	539-638-23		
400E	12	539-763-11	539-763-21	539-763-51	539-763-61
	14	539-763-13	539-763-23		

Optional items	Art. No.
Remote control, receiver card included	532-510-01
Remote control, receiver card excluded	532-460-01
Additional receiver card	532-465-01
Stainless steel panel for switches (100 x 56 x 3 mm)	540-462-01
Emergency handle (1/2" socket)	533-922
Ø 6/7 mm eye/fork extension link, L=90 mm	517-070-01
Ø 8/10 mm eye/fork extension link, L=130 mm	517-071-01
Ø 12 mm eye/fork extension link, L=190 mm	517-072-01
Ø 14 mm eye/fork extension link, L=190 mm	517-073-01

For further technical information, please see our instructions for installation, [www.seldenmast.com](http://www.seldenmast.com).